

THE  
**Elks**  
MAGAZINE



DECEMBER 1954

**COLONIALISM PASSES**

BY ROBERT AURA SMITH

*woods inkman*



# only Lord Calvert

says: "To a Man of Distinction!"



MR. WILLIAM PAHLMANN, distinguished interior designer

*America's Most  
Distinguished Gift Whiskey  
in the Season's Most  
Distinguished Gift Package*  
SILVER OR GOLD

You can't give a *finer* gift than Lord Calvert . . . and packaged in a gold or silver Treasure Chest, it's the *handsomest* gift, too! What's more, no other gift is so flattering . . . for Lord Calvert says: "To a Man of Distinction!" Can you think of a nicer way to please the men on *your* list?

BLENDED WHISKEY. 86.8 PROOF. 65% GRAIN NEUTRAL SPIRITS. CALVERT DISTILLERS COMPANY, NEW YORK CITY



**NOW!**  
**The Greatest**  
**HOSPITALIZATION**  
**VALUE**  
**EVER OFFERED**



Smiling and healthy today — in a Hospital bed tomorrow! It can happen to you, and with shocking suddenness!



Sky-high Hospital bills can wreck your life savings if you don't have enough Hospitalization. Mail Coupon Below!



Look ahead! Think what a blessing it will be to fall back on reliable help with those Hospital bills. ACT NOW!

**PROTECTS YOU and YOUR FAMILY**  
**IN CASE OF SICKNESS or ACCIDENT..**

# No Time Limit HOSPITAL PLAN

PAYS BENEFITS FOR FULL STAY IN HOSPITAL

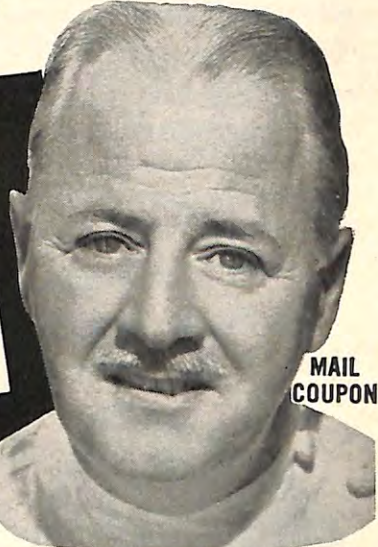

MAIL COUPON

COSTS ONLY  
**Pennies a Day**

## WE PAY CASH DIRECT TO YOU

IN ADDITION TO WHAT YOU MAY COLLECT FROM OTHER INSURANCE  
 Go to the Hospital for a day, a week, a month, a year or longer — your "NO TIME LIMIT" Policy pays Benefits just as long as you stay — *there's absolutely no time limit!*



**This Policy is Sold Only By Mail! . . . It's Good Anywhere in U.S. and Possessions!**  
 If sickness or accident puts you in a Hospital bed — you'll look back and thank your lucky stars you were wise enough to take out the "NO TIME LIMIT" Policy. It's the sensible, practical way to protect your own bank account against the onslaught of high Hospital costs. Ask anyone who's been through a siege of Hospital bills. They'll tell you what a comfort it is to have good, safe Hospitalization to fall back on. And we offer you so much more for your money. So ACT TODAY! Do it before trouble strikes.



SO SUDDEN!

**YOU CAN GET MATERNITY**  
 For slight extra cost husband and wife can have a MATERNITY RIDER attached to their regular Policy and this will entitle the couple to a liberal Benefit for childbirth confinement and care.



### ACCIDENTAL DEATH, SURGERY, POLIO INCLUDED

This is truly the opportunity of a lifetime. We give you more coverage, better coverage, longer coverage at a low cost you can easily afford. The "NO TIME LIMIT" Policy "thinks" of everything. You get generous Hospital Room and Board Benefits for sickness or accident (rest homes, sanitariums and Govt. Hospitals excluded) . . . you get Cash Benefits for 73 Surgical Operations . . . Lump Cash for accidental death . . . Cash Payment for loss of eyes, hands, feet . . . special Polio Protection, plus still other valuable coverages. Maternity Rider is available at slight extra cost. There's no waiting period for benefits to start. One Policy covers individual or entire family, birth to age 75. You'll see the low costs in the booklet we send you. Remember — all benefits are paid in CASH DIRECT TO YOU. DON'T TAKE CHANCES — BE PROTECTED. Send for our FREE BOOK which tells all about this remarkable, low cost insurance value.

**DON'T WAIT TILL IT'S TOO LATE! ACT NOW!**



HAPPY DAY!

WHO'S NEXT?

### RUSH COUPON FOR VALUABLE FREE BOOK

**LIFE INSURANCE CO. OF AMERICA**  
 Dept. 1254-E, Wilmington 99, Del.  
 Please send me, without obligation, full details about your new, low cost NO TIME LIMIT HOSPITAL Plan. No agent will call.

Name .....

Address .....

City ..... Zone ..... State .....

**POLICY BACKED BY STRONG RELIABLE COMPANY**  
 Our growth and strength lies in the good service we give our Policyholders. We do business in all 48 states and U. S. possessions. Claims are paid promptly in strict accordance with Policy provisions.  
**LIFE INSURANCE CO. OF AMERICA**  
 Wilmington 99, Delaware

Mail Coupon for  
**FREE BOOK**  
 NO OBLIGATION  
 NO AGENT WILL CALL



# the boy and the Star

He is old enough now to know that the ornament on the tree is more than a star . . . to understand the deeper meaning of Christmastime.

Now he knows that it is love that has been shining on the tree year after year, the love that has wrapped and held him.

Life's great reward is the privilege of giving security to those we love.

And, think: When you make your home secure you are also helping make America secure.



Saving for security is easy—on the Payroll Savings Plan for investing in United States Savings Bonds.

This is all you do. Go to your company's pay office, choose the amount you want to save—a few dollars a payday, or as much as you wish. That money will be set aside for you before you even draw your pay. And automatically invested in United States Series "E" Savings Bonds which are turned over to you.

If you can save only \$3.75 a week on the Plan, in 9 years and 8 months you will have \$2,137.30.

U.S. Series "E" Savings Bonds earn interest at an average of 3% per year, compounded semiannually, when held to maturity! And they can go on earning interest for as long as 19 years and 8 months if you wish.

If you want your interest as current income, ask your bank about 3% Series "H" Bonds which pay interest semiannually by Treasury check.

The U.S. Government does not pay for this advertisement. It is donated by this publication in cooperation with the Advertising Council and the Magazine Publishers of America.



# THE Elks MAGAZINE

VOL. 33

No. 7

NATIONAL PUBLICATION OF THE BENEVOLENT AND PROTECTIVE ORDER OF ELKS OF THE UNITED STATES OF AMERICA. PUBLISHED UNDER THE DIRECTION OF THE GRAND LODGE BY THE NATIONAL MEMORIAL AND PUBLICATION COMMISSION.

THE ELKS NATIONAL MEMORIAL AND PUBLICATION COMMISSION

BRUCE A. CAMPBELL  
Chairman  
JOHN R. COEN  
Vice-Chairman  
JOHN S. McCLELLAND  
Secretary  
EMMETT T. ANDERSON  
Asst. Secy. and Asst. Treas.  
JAMES T. HALLINAN  
Treasurer

JAMES R. NICHOLSON  
General Manager  
LEE C. HICKEY  
Editor  
REGINA M. FISHER  
Associate Editor  
JOSEPH C. JONES  
Art Editor  
W. H. MAGRATH  
Controller  
JOHN SCHMITT  
Circulation Manager  
GENEVIEVE G. CONOVER  
Advertising Production  
EDWARD FAUST  
Promotion Manager

EDITORIAL OFFICES, 50 East 42nd Street, New York 17, N. Y.

## CONTENTS FOR DECEMBER, 1954

COVER BY WOODI ISHMAEL

CHOICE OF WEAPONS.....	William Fay	4
THE GRAND EXALTED RULER'S VISITS.....		6
"... TO KEEP CHRISTMAS WELL" National Service Commission		9
COLONIALISM PASSES.....	Robert Aura Smith	10
NEWS OF THE LODGES.....		12
NEWS OF THE STATE ASSOCIATIONS.....		15
ROD AND GUN.....	Dan Holland	16
A CHRISTMAS MESSAGE FROM THE GRAND EXALTED RULER		17
ANOTHER PAGE FOR YOUR ELK FAMILY ALBUM.....		18
TOM WRIGLEY WRITES FROM WASHINGTON.....		23
FOR ELKS WHO TRAVEL.....	Horace Sutton	24
ELKS FAMILY SHOPPER.....		26
IN THE DOGHOUSE.....	Ed Faust	34
POLIO IS NOT BEATEN.....		40
1954-55 GRAND LODGE OFFICERS AND COMMITTEEMEN.....		49
ELKS WORKSHOP.....	Harry Walton	50
EDITORIAL.....		52

### ADVERTISING OFFICES

CHICAGO 1  
360 North Michigan Avenue  
STATE 2-6662

NEW YORK 17  
50 East 42nd Street  
VANDERBILT 6-4660

LOS ANGELES 17  
1709 West 8th Street  
DUNKIRK 8-5187

DETROIT 2  
2970 West Grand Boulevard  
TRINITY 5-7026

SAN FRANCISCO 4  
1204 Russ Building  
SUTTER 1-2251

CHANGE OF ADDRESS: POSTMASTER—Please mail Form 3579 notices to: THE ELKS MAGAZINE, 50 East 42nd Street, New York 17, N. Y.

Members are asked, in changing address, to send this information (1) Name; (2) Lodge number; (3) Membership number; (4) New address; (5) Old address. Please allow 30 days for a change of address to be effected. THE ELKS MAGAZINE, Volume 33, No. 7, December, 1954. Published monthly at McCall Street, Dayton, Ohio, by the Benevolent and Protective Order of Elks of the United States of America. Entered as second class matter November 2, 1940, at the Post Office at Dayton, Ohio, under the Act of October 3, 1917, authorized May 20, 1922. Printed in Dayton, Ohio, U.S.A. Single copy price, 20 cents. Subscription price in the United States and its Possessions, for Elks \$1.00 a year; for non-Elks, \$2.00 a year; for Canadian postage, add 50 cents a year; for foreign postage, add \$1.00 a year. Subscriptions are payable in advance. Manuscripts must be typewritten and accompanied by sufficient postage for their return via first class mail. They will be handled with care but this Magazine assumes no responsibility for their safety. Copyright, 1954, by the Benevolent and Protective Order of Elks of the United States of America



## Action on Parking

**A**N ARTICLE that Stanley Frank wrote for a recent issue about the acute problem virtually every community is facing with regard to parking has attracted unusual interest, no doubt because it hit so close to home. The basic thought that Mr. Frank projected in the article was that parking is in the same category as other public services, and it is up to each community to provide adequate space rather than expect local business to handle the matter.

It is very gratifying that many readers have asked for extra copies to place in the hands of their local Chamber of Commerce and other community organizations.

To cite just a few of the responses, we can start with Brother John D. Frakes, Secretary of Tucson, Ariz., Lodge, who requested fifty copies of the article for the local Chamber of Commerce. Allen B. Stephenson, Senior Analyst of the City of Los Angeles, heard about the article and asked for a copy. Brother Samuel B. Fryer, President of Bridgeville, Pa., Chamber of Commerce, wrote for twelve copies for distribution to the local council and Chamber of Commerce. Brother Al Ochs of Faribault, Minn., asked for ten copies, and A. T. Brout, President, Newmarket Village Shopping Center, Newport News, Virginia, at his own expense had us reprint, in the original colors, 1,500 copies of the illustration which accompanied the article.

Joseph G. Conrath, a Consulting Engineer in New York, requested copies and had this comment to make: "The article 'Parking Problems Can Be Solved' by Stanley Frank attracted my attention because it closely approaches our present campaign to relieve the traffic and parking problems."

Brother J. H. Galliver of Flint, Mich., Lodge, said: "Stanley Frank in the September issue calls them correct. He is well informed and knows his subject."

Brother Wesley McDonnell, of Vancouver, Wash., Lodge, sent a most gratifying letter, saying: "The very interesting article on parking problems appearing in The Elks Magazine was read and discussed in our office this morning. I was asked to communicate with you to see if it is permissible for us to reproduce that article entirely, or in part, to be used in our efforts at relieving the parking problems of this community."

Of course, The Elks Magazine is always willing, in fact pleased, to grant reprint permission of any article when the use is non-commercial.

### *Christmas Reminder*

As we enter the Holiday Season, here is a thought for Elks who have a Brother from their lodge living at the Elks National Home at Bedford, Va. Send him a card or drop him a line. You have no idea how much it will be appreciated by your aged Brother.



## 20 MILLION BOWLERS WOULD LOVE THIS CHRISTMAS GIFT

... and why not? Ebonite is not only the truest most responsive ball in bowling, made by the inventors of the rubber bowling ball and guaranteed for five years ...

... Ebonite is also a complete better bowling service, sure to improve anybody's scoring.

Ebonite's patented Grips (Bates, Curval and Flat) are expertly engineered to give you better, easier ball-handling, the key to better bowling.

And Ebonite's grip-fitting gadget (the Ebonizer) with more than 600,000 micromatically accurate measuring adjustments guarantees the proper fit for your individual hand.

An Ebonite Ball and Grip... With Ebonizer Grip-Fitting —

### THAT'S THE CHRISTMAS GIFT FOR BOWLERS!

Ebonite Gift Certificates Are Available Where You Bowl.  
Ebonite Distributors in All Principal Cities. Write for free 16-page booklet "From Roller to Bowler"

# EBONITE CO.

NEWTON 64, MASSACHUSETTS



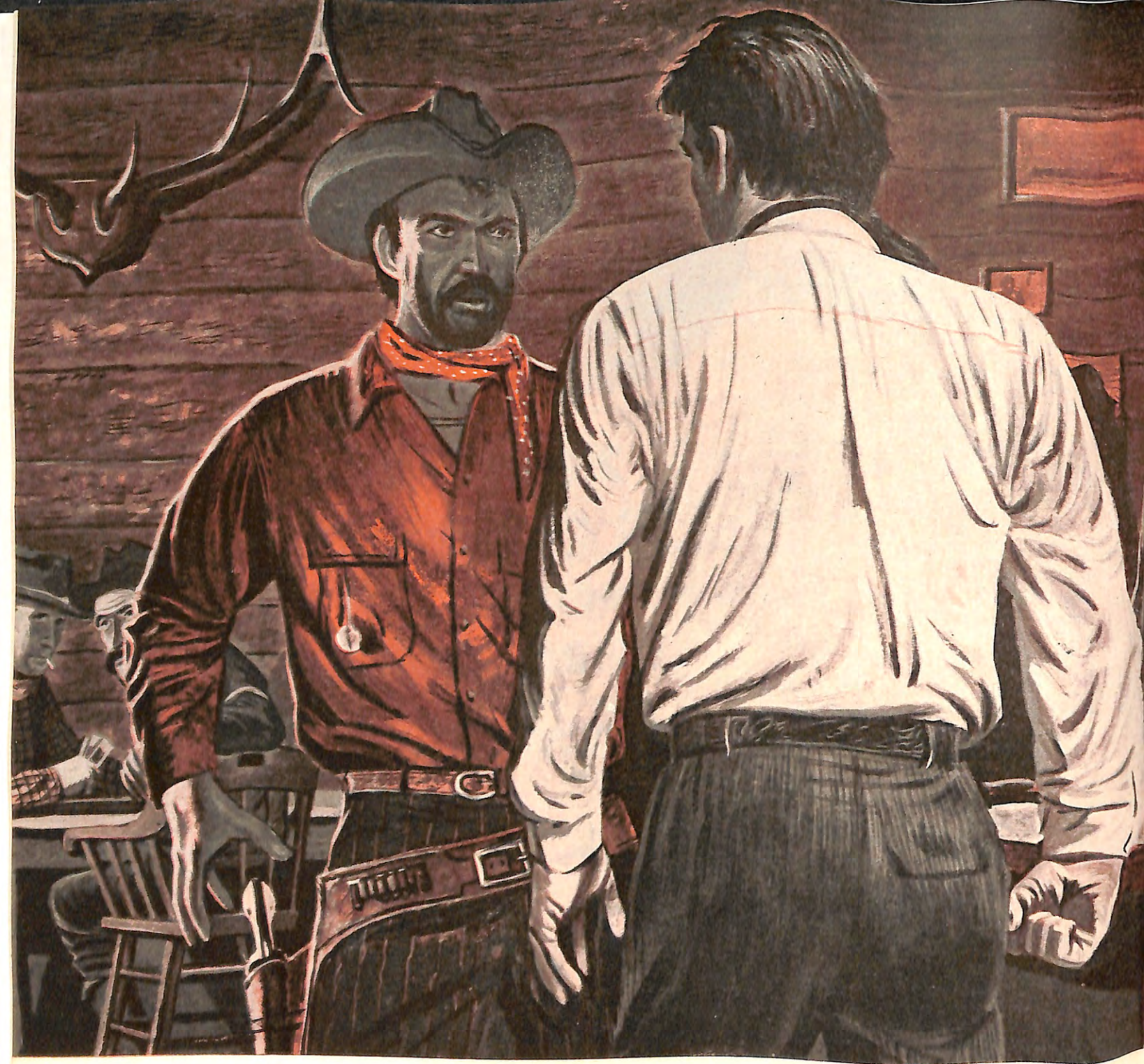

# CHOICE OF WEAPONS

*If he would backdown,  
he could catch the  
stage—or he could stay  
and face a gun.*

BY WILLIAM FAY





**ILLUSTRATED BY HERB MOTT**

**"It's better than nothing, Dan. Don't let him shoot you like a rattler."**

THE Sports came early, if clandestinely, to the appointed place of battle. There was no evidence the police had been informed. Many of the crowd had made the narrow crossing from New Jersey, while others had journeyed the longer way, by barge and tow, from old Manhattan, across the waters of the Upper Bay. A cool wind washed the Staten Island shore. And hearts grew rapid as the time of action crowded near.

"Here is the Tinsmith now!" somebody shouted.

The great one whom the followers of the "Fancy" most admired—the heavy-walking man they called "The Tinsmith," came from the fringe of the forest, dressed in long tights from his waist to his fighting shoes, his great chest bared to the rising wind, his derby still on his head. He stepped into the roped

square where the battle would be made. He rolled his great hands into fists.

"Three cheers for the Tinsmith!" a thousand men called lustily. "Three cheers for the winner of many a mill!"

This was the way that those most faithful to the Tinsmith always cheered him. A warrior of dignity, he acknowledged their good will. He bowed, raising his derby with that flair of courtesy for which he was well known. It was the spring of 1887—a gracious and a cultivated time when fighting with fists, for cash or for a prize, was forbidden under the law. It was especially diverting for this reason to have the Tinsmith raising his hands against a reckless youth who was a New York City policeman. *(Continued on page 38)*



# THE GRAND EXALTED RULER'S *Visits*



Early in his term of office, at the Wisconsin State Assoc. Convention, Grand Exalted Ruler Jernick received some good advice from three able predecessors, left to right: Past Grand Exalted Rulers Henry C. Warner, Sam Stern and Charles E. Broughton.

Grand Trustee Douglas E. Lambourne, District Deputy Warren H. Bulloch and Frank Delvie, Exalted Ruler of **SALT LAKE CITY LODGE NO. 85**. The group then proceeded to the Church Offices of the Church of the Latter Day Saints for a visit with President David O. McKay. President McKay congratulated the Grand Exalted Ruler for the fine work being done by the Order. Basing his opinion on the good work being done locally by Salt Lake City Lodge, he stated his opinion that the presence of an active Elks lodge must be a force for good in any community.

That evening a banquet attended by more than 200 Elks from all parts of Utah was given by Salt Lake City Lodge in honor of Grand Exalted Ruler Jernick. Exalted Ruler Frank Delvie welcomed all the guests to the Lodge and then introduced Past Grand Trustee Douglas E. Lambourne, who is a Past Exalted Ruler of the Lodge and who acted as Master of Ceremonies. Among those present were Mayor Earl Glade who extended the official welcome of the city, Chamber of Commerce President Gus Backman who expressed the good wishes of his group and State Tax Commission Chairman Byron Jones acting as representative of the Governor. Other prominent guests were Wyoming District Deputy James P. Steele, District Deputy Warren H. Bulloch and State Association President William Beazer.

The banquet was followed by a Lodge meeting attended by Elks from all over the state, including Past District Deputies, Past State Presidents and the Exalted Rulers of all of Utah's 10 lodges.

**G**RAND EXALTED RULER William J. Jernick, accompanied by Mrs. Jernick and Past Grand Exalted Ruler L. A. Lewis, arrived in Reno, Nevada, on Sunday afternoon, October 10th. They were greeted at the airport by Grand Esteemed Loyal Knight Sidney W. Robinson and William R. Beemer and J. C. Kumle, Exalted Ruler and Secretary, respectively, of **RENO LODGE NO. 597**.

Next evening, after spending the afternoon at Lake Tahoe, the group was entertained at a cocktail party given by Mr. Robinson and attended by all Past Exalted Rulers and officers of Reno Lodge and their ladies. Later that evening Mr. Jernick addressed an audience of more than 200 Elks and their ladies at a banquet given in his honor by Reno Lodge.

On Tuesday, Oct. 12th, the Grand

Exalted Ruler was taken by automobile to Ely, Nevada. His party, which included a large delegation from Reno Lodge, was entertained, that evening, at a cocktail party. There followed a well attended banquet given by **ELY LODGE NO. 1469** in Mr. Jernick's honor and presided over by E.R. Boyd K. Smith. District Deputy Donald S. Shaver, acting in behalf of the Lodge, presented a copper plated milk can inscribed with the Grand Exalted Ruler's name to the State Association to be used in raising money for the Crippled Children Program.

On Wednesday morning, Mr. and Mrs. Jernick and Past Grand Exalted Ruler Lewis departed for Salt Lake City, Utah, accompanied by District Deputy Shaver and Exalted Ruler Boyd K. Smith. Upon their arrival they were welcomed by Past

Photographed during the Grand Exalted Ruler's visit to Springfield, Vt., Lodge were, left to right: Past Grand Exalted Ruler E. Mark Sullivan, Mr. Jernick, Exalted Ruler Merle A. Page, Jr., Past Grand Exalted Ruler John F. Malley and D.D. Charles F. Hillmann.



Seen here at Laramie, Wyoming, Lodge are, left to right, front: D.D. James P. Steele, Grand Est. Lect. Knight Jacob L. Sherman, Mr. Jernick, Grand Lodge Credentials Comm. Chairman Hollis B. Brewer, D.D. Campbell F. Rice. Back row: Joe O. Spangler, Paul McKelvey, Everton B. Cope and L. G. Mehse, President, Vice-Pres., Trustee and Secretary, respectively, of the Wyoming State Association.



Each of the Exalted Rulers gave a short account of his lodge, its activities and items of interest. District Deputy Bulloch then introduced Grand Exalted Ruler Jernick whose inspiring address was enthusiastically received by the more than 400 Elks present, many of whom had traveled as far as 350 miles to attend the function.

Next day Mr. Jernick made an informal visit to **PROVO LODGE NO. 849** for a luncheon with a group of the lodge officers and Past Exalted Rulers. That afternoon he visited the Bingham Canyon Copper Mine, largest open pit copper mine in the world, took a trip around Great Salt Lake, and attended an organ recital in his honor at the Mormon Tabernacle. Mr. and Mrs. Jernick were the guests at dinner that evening of a small group of Salt Lake City Lodge officers, Past Exalted Rulers and State officers.

On Friday, Mr. and Mrs. Jernick, accompanied by Wyoming District Deputy and Mrs. James P. Steele, left on a tour of Wyoming lodges. En route, the plane made a brief stop at Rock Springs, Wyoming, where the Grand Exalted Ruler was greeted by a delegation of Elks of **ROCK SPRINGS LODGE NO. 624** headed by Exalted Ruler Paul Wonnacott. The plane stopped again briefly at Rawlins, Wyoming, where a large group of Elks of **RAWLINS LODGE NO. 609** were on hand to meet Mr. Jernick.

The party arrived later that morning at Laramie where they were welcomed by members of **LARAMIE LODGE NO. 582** and visiting Elks, including Grand Lodge Credentials Committee Chairman Hollis B. Brewer, Grand Esteemed Lecturing Knight Jacob L. Sherman of Denver, and Colorado District Deputy Campbell F. Rice. The group then proceeded by motor caravan with police escort to the downtown area. Mr. and Mrs. Jernick were entertained at a luncheon attended by the lodge officers, local and visiting dignitaries and their ladies.

That evening, after a banquet given  
(Continued on next page)



At the dinner given by Ely, Nevada, Lodge in honor of the Grand Exalted Ruler, District Deputy Donald S. Shaver, left, dedicated this copper plated milk can in Grand Exalted Ruler Jernick's name, as a fund raising device in the State Association Program for Crippled Children. Looking on, left to right, are: Grand Est. Loyal Knight Sidney W. Robinson, Mr. Jernick, Exalted Ruler Boyd K. Smith, and Past Grand Exalted Ruler L. A. Lewis, who made the first donation.



Photographed during the Grand Exalted Ruler's visit to Salt Lake City, Utah, Lodge were, left to right, front: Past Grand Exalted Ruler L. A. Lewis, E.R. Frank Delvie, State Assn. Pres. William Beazer, Grand Exalted Ruler Jernick, D.D. Warren H. Bulloch and James Hannifin, Exalted Ruler of Eureka Lodge. In the back row are the Exalted Rulers of all other Utah lodges.



Past Grand Exalted Rulers E. Mark Sullivan and John F. Malley and Grand Exalted Ruler William J. Jernick are welcomed to Keene, N.H., Lodge during Mr. Jernick's tour of New England Lodges by E.R. Irving Slater as Mayor Lawrence Pickett looks on.



Pictured during the Grand Exalted Ruler's visit to Reno, Nevada, Lodge, left to right: Past Grand Exalted Ruler L. A. Lewis, Exalted Ruler William R. Beemer, Mr. Jernick, Grand Est. Loyal Knight Sidney W. Robinson and District Deputy Donald S. Shaver.





### Grand Exalted Ruler's Itinerary\*

- DEC. 2 St. Louis, Mo.
- 3 Clayton, Mo., dedication of new lodge home.
- 4 Washington, Mo.
- 9 Irvington, N.J.
- 11 Boy's Town, Arlington, N.J., under auspices of Lyndhurst and Kearney, N.J. Lodges.
- 14 Penn's Grove, N.J., dinner meeting.
- 15 East Stroudsburg, Pa.
- 15 Lehighton, Pa.
- 16 Lebanon, Pa.
- 19 Trenton, N.J.

\*Subject to change

About to board one of six motor yachts on which he and his party enjoyed a scenic ride across Lake Winnepesaukee to Laconia, N.H., Mr. Jernick, sixth from right, is seen with, left to right: Brian M. Jewett of the Grand Lodge Youth Activities Committee, D.D. Joseph Collette, P.D.D. Fred Tilton, State Assn. Pres. Timothy D. Flynn, P.E.R. Howard Ballou and E.R. Joseph Killourhy of Laconia Lodge, Past Grand Exalted Rulers John F. Malley and E. Mark Sullivan, and Grand Trustee Edward A. Spry.

in his honor by Laramie Lodge, Mr. Jernick was principal speaker at an extremely well attended Lodge meeting. Among the prominent Wyoming and out of state Elks in attendance were: Grand Esteemed Lecturing Knight Sherman, Grand Lodge Credentials Committee Chairman, Brewer, Colorado D.D. Rice, and Joe O. Spangler, Paul McKelvey, Everton B. Cope and L. G. Mehse, President, 1st Vice-President, Trustee and Secretary, respectively, of the Wyoming State Elks Association.

The next day, October 16th, Grand Exalted Ruler and Mrs. Jernick, accompanied by District Deputy and Mrs. Steele and Mr. Brewer, left for Sheridan. The group was greeted during a brief stop at Casper by members of CASPER LODGE NO. 1353. Upon their arrival at Sheridan, they were welcomed by a large delegation headed by District Deputy Guy Sturgeon and including several Past District Deputies and Robert H. Mulholland and W. M. Poulson, Exalted

Ruler and Secretary, respectively, of SHERIDAN LODGE NO. 520. Mr. Jernick then participated with District Deputy Sturgeon in a 15-minute interview over the local radio station.

A luncheon attended by the welcoming committee was held at Sheridan Lodge for Mr. Jernick, following which he visited the newly completed Elks cemetery and the Veterans Hospital where Sheridan Elks have been active in main-

taining a program for the entertainment of disabled veterans.

That evening the Grand Exalted Ruler was honored at a banquet attended by visiting Elks, Past Exalted Rulers and officers of Sheridan Lodge. At the Lodge meeting which followed attendance was swelled by the presence of delegations from eight lodges in Wyoming, Montana and Utah. Following the Lodge meeting, a dance was held.



Upon their arrival at Sheridan, Wyoming, Grand Lodge Credentials Committeeman Hollis B. Brewer, Grand Exalted Ruler and Mrs. Jernick and District Deputy and Mrs. James P. Steele were greeted by District Deputy Guy Sturgeon, a Past Exalted Ruler of Sheridan Lodge.



Exalted Ruler George C. Foy of Quincy, Mass., Lodge, left, invites the Grand Exalted Ruler to be the guest of honor at Quincy Lodge's Golden Anniversary Celebration in February.

At the dinner given by Dunkirk, N.Y., Lodge are, left to right, seated: Exalted Ruler Gordon Gast, Mr. Jernick, State Vice President, New York West, John F. Hayes. Standing: State Scholarship Committee Chairman Franklin J. Fitzpatrick, Past District Deputies J. William Murphy and K. W. Glines, Past Grand Lect. Knight J. Theodore Moses and P.D.D. John J. Mahaney.





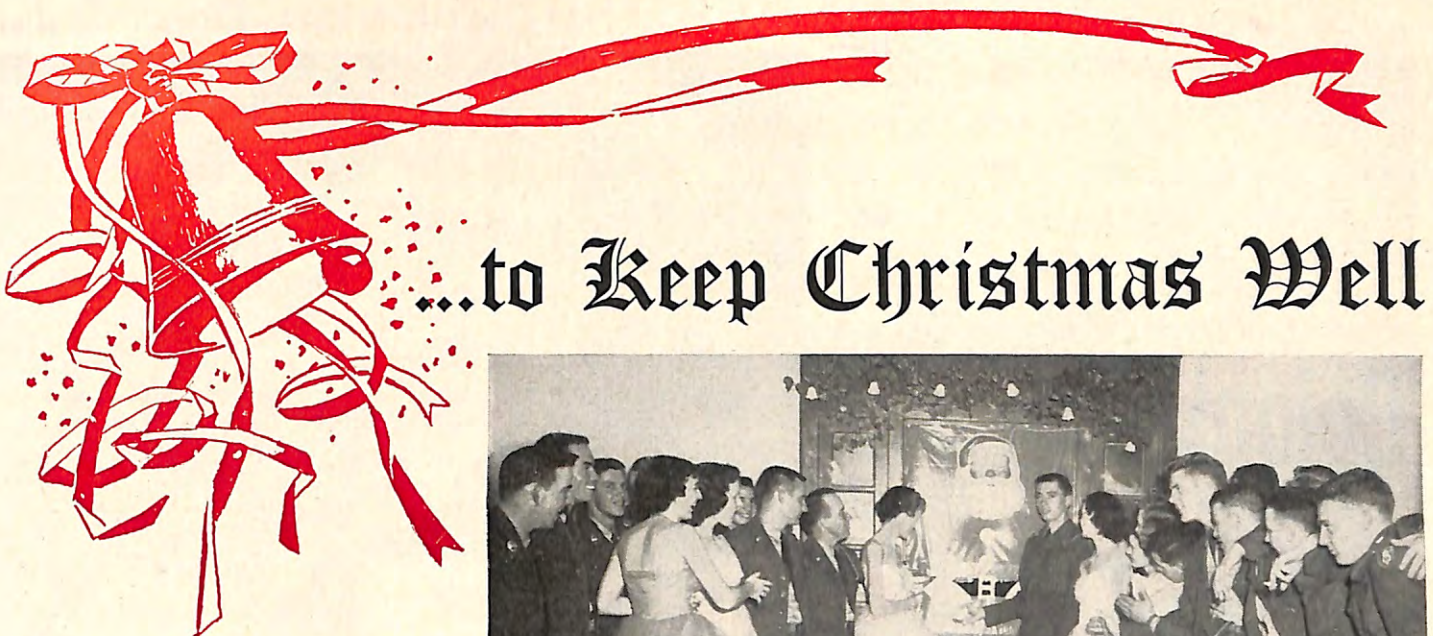

# ...to Keep Christmas Well

**T**HIS page is designed to give a picturization of what is occupying the attention of the members of all our Veterans Service Committees during this period of the year.

Scenes like these will be taking place all over our land—wherever a serviceman may be located, or a veteran is hospitalized, and there is an Elk who knows about him.

In the VA Hospital wards and recreation rooms they decorate, in Fraternal Centers and in lodge homes, members of the Order and their families are bringing to our Nation's defenders that kindly, friendly Spirit of Christmas that is so much a part of our way of life. They will do this in the form of gifts, parties and entertainment, to compensate for the absence of home and loved ones.

But over and above the material evidence of our appreciation of their sacrifices, will be the warm, gracious touch of our personal visits.

For this is the Time of Giving.





# Colonialism Passes

*To serve the cause of justice and equity, we must continue to help the free world to govern only by consent.*

**BY ROBERT AURA SMITH**

ON SEPT. 8, 1954, there was signed in Manila not merely a treaty of mutual defense obligation among eight powers in the free world. There was also set forth and signed an agreement between free powers of the East and the West on a declaration of principle that involved their full commitment to end what is called "colonialism." The preamble of the Defense Treaty and the first definitive paragraph of the "Pacific Charter" have identical wording. This is what is said:

"In accordance with the provisions of the United Nations Charter, they [the eight signatories] uphold the principle of equal rights and self-determination of peoples, and they will earnestly strive by every peaceful means to promote the self-government and to secure the independence of all countries whose peoples desire it and are able to undertake its responsibilities."

This is not the mere expression of a pious wish. It is a firm treaty commitment. Moreover, the Pacific Charter goes further and envisages action to bring about this end. It says:

"Second, they [the signatories] are each prepared to continue taking effective practical measures to insure conditions favorable to orderly achievement of the foregoing purposes in accordance with their constitutional procedures."

What countries signed such a declaration of principle? The Communist states? Certainly not. The "neutrals"? Not at all. It was signed by three countries that have been "colonial" powers—Great Britain, France and the United States. They were joined by two Pacific powers that have trusteeship responsibilities for dependent peoples—Australia and New Zealand. To them were added two Asian powers that have recently become independent—Pakistan and the Philippines. And the eighth signer was the oldest free state in Southeast Asia, Thailand.

"The age of colonialism is dead," Queen Wilhelmina of the Netherlands said prophetically in 1942. She was right, and the nations of the free world are vindicating her. More than a score of countries have attained outright independence or greatly increased self-government within the last twenty-five years. There is, however, still some way to go before the principle of complete self-determination is established throughout the whole of the free world. The Pacific Charter, in large part the product of the efforts of a man who saw the transition from dependency to independence in the Philippines, Brig. Gen. Carlos P. Romulo, sets a goal and points a way. That way must be taken if the free world (*Continued on page 44*)

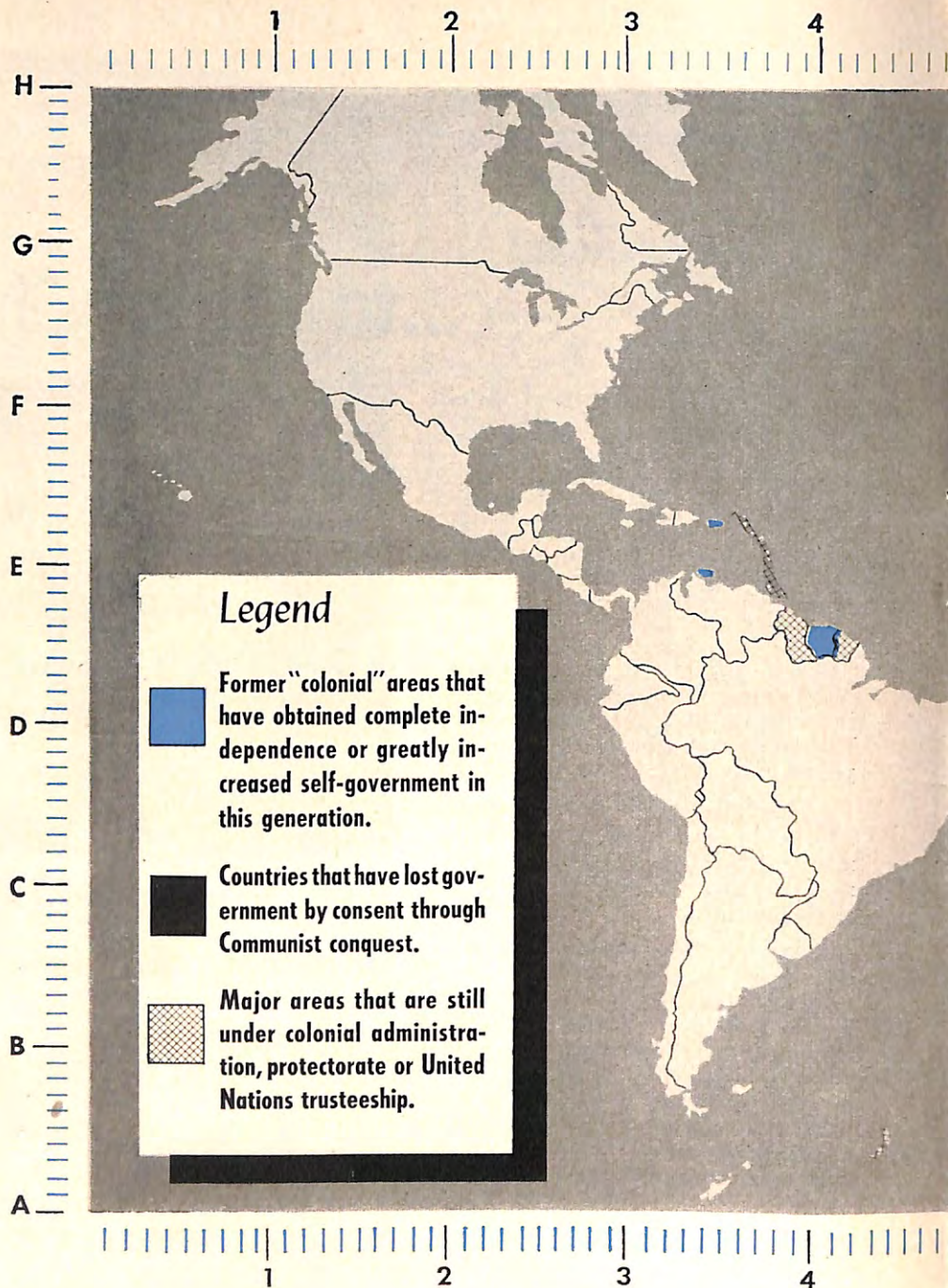



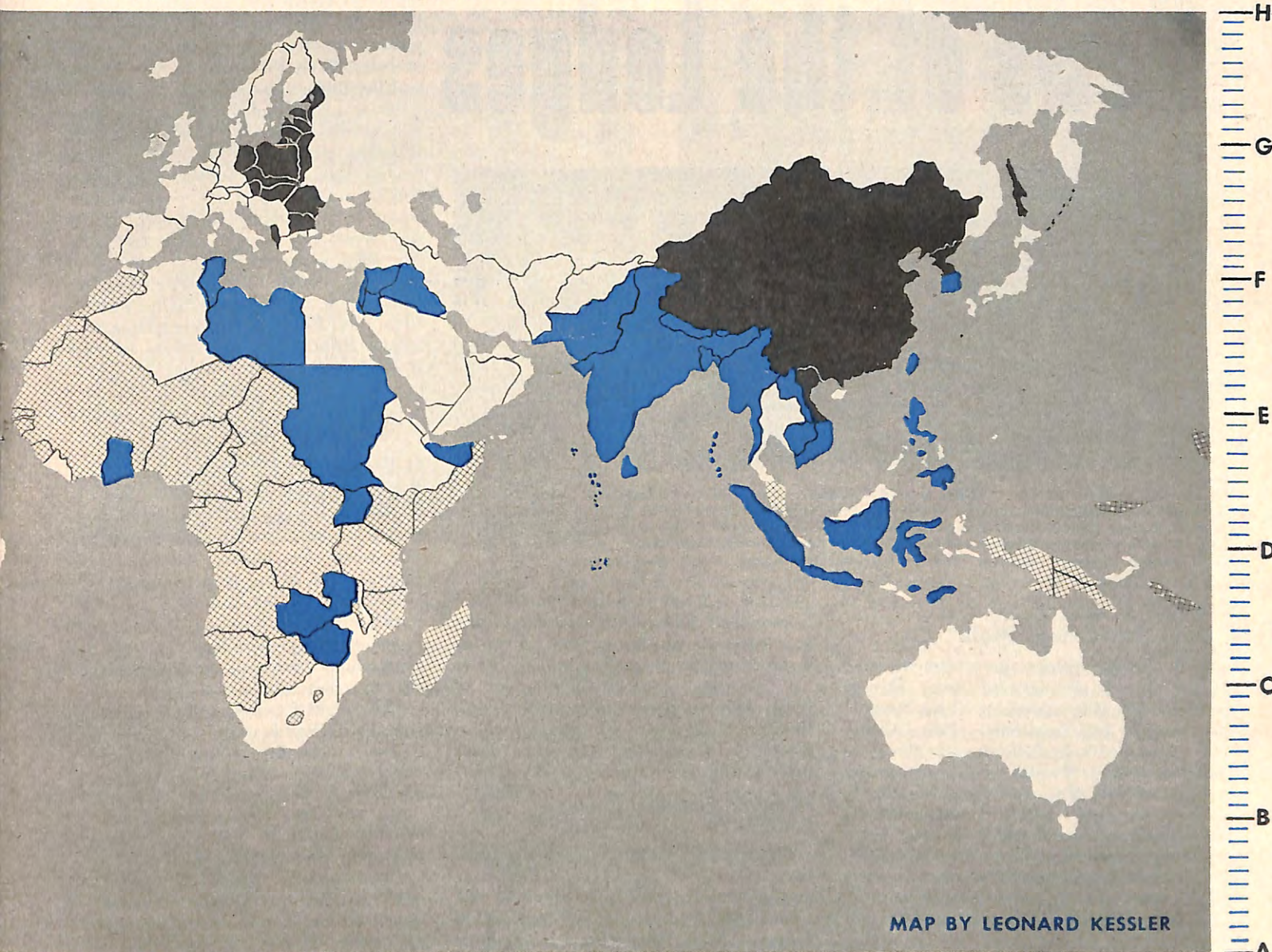

5 6 7 8 9 10 11 12 13



MAP BY LEONARD KESSLER

5 6 7 8 9 10 11 12 13

To pinpoint areas, see key after name. For example, to find Libya, plot number 6.7 horizontally, then E.6 vertically.

<p> Libya 6.7-E.6 Anglo Egyptian Sudan 7.2-E Uganda 7.3-D.4 Northern Rhodesia 7.2-C.6 Southern Rhodesia 7.1-C.3 Sumatra 10.1-D.1 Borneo 10.7-D.2 Eritria 8.0-D.7 Celebes 10.9-D.0 Philippine Republic 11.0-D.9</p>	<p>Java 10.5-C.8 Netherland Antiles 3.4-E.0 Surinam 4.1-D.7 South Korea 11.2-E.9 Formosa 11.0-E.3 India 9.1-E.4 Southern Vietnam 10.3-D.7 Cambodia 10.2-D.8 Laos 10.2-E.2 Turisia 6.4-F.1</p>	<p>West Pakistan 8.9-E.7 East Pakistan 9.7-E.4 Nepal 9.4-E.6 Iraq 7.7-E.9 Syria 7.6-E.9 Lebanon 7.4-E.9 Burma 9.9-E.4 Puerto Rico 3.5-E.3 Ceylon 9.1-D.6</p>	<p>Maldiv Islands 8.9-D.5 Chagos Islands 9.0-C.9 Israel 7.4-E.8 Jordan 7.8-E.8 Andaman Islands 9.7-D.8 Nicobar Islands 9.8-D.6 Indonesia 11.0-D.0 Gold Coast 5.7-D.7 Laccadive Islands 8.9-D.5</p>
<p> Karelia 7.0-G.5 Latvia 7.0-G.2 Estonia 7.0-G.3 Lithuania 6.9-G.1 Rumania 7.1-F.7</p>	<p>Hungary 6.9-F.7 Czechoslovakia 6.8-F.8 Bulgaria 7.0-F.5 Albania 6.8-F.4 East Germany 6.6-F.9</p>	<p>Poland 6.8-F.9 East Prussia 7.9-G.1 Tannu Tuva 10.1-F.8 Outer Mongolia 10.3-F.7 Kuriles 12.0-F.5</p>	<p>China 10.3-F.0 North Korea 11.2-F.2 North Vietnam 10.3-E.1 Tibet 9.6 Sakhalin 11.6-F.6</p>
<p> Somalia 7.9-D.4 Kenya 7.5-D.3 Tanganyika 7.4-C.9 Mozambique 7.5-C.6 Swaziland 7.1-C.0 Bechuanaland 6.9-C.4 South West Africa 6.6-C.1</p>	<p>Angola 6.5-C.6 Belgian Congo 6.9-D.2 French Equatorial Africa 6.7-D.8 Cameroons 6.4-D.7 Nigeria 6.2-D.9 French West Africa 5.5-E.2 Nyasaland 7.3-C.6</p>	<p>Rio De Oro 5.3-E.6 Sierra Leone 5.2-D.8 Morocco 5.7-F.0 New Guinea 11.9-C.9 Malaya 10.2-C.4 British Guiana 3.9-D.7 French Guiana 4.1-D.6</p>	<p>Martinique 3.7-E.2 Guadeloupe 3.6-E.3 Sandwich Islands 4.4-A.5 Madagascar 7.9-C.4 Solomon Islands 12.6-C.7 Marshall Islands 12.9-D.8 Caroline Islands 12.3-D.3</p>



# News of the Lodges



E.R. Clyde Williams congratulates Gerald Boehmer, center, leader of Boy Scout Troop 20 sponsored by Sterling, Colo., Lodge which won top national honors in the 1954 Camporall of all Blue Ribbon Patrols of its Council scoring 1036 points against the runner's-up 1031. Others pictured are Charles Chandler, Lowell Fortner, Kenny Bauer, John White, James Kaiser, Allen Rosenbach, Richard Ledbetter, Charles Palvado, Tim Boggs and Richard Hamilton.

## Santa Monica, Calif., Elks Pass Half-Century Mark

A four-day celebration commemorated the 50th Anniversary of Santa Monica Lodge No. 906, highlighted by a banquet attended by hundreds. Past Grand Exalted Ruler L. A. Lewis was the principal speaker, sharing the dais with many other dignitaries, including Donald L. Jackson of the House of Representatives.

A special ceremony conducted by a selected group of officers of other Calif. lodges saw 50 candidates enter No. 906 in honor of D.D. Floyd Tumbleson.

A Grand Ball was the main social event, with open house and entertainment throughout the final day.

Below: Pictured at the institution of Amherst, N. Y., Lodge, No. 1942, are, left to right: James A. Gunn of the Lodge Activities Committee of the Grand Lodge, No. 1942's Secy. Joseph F. Rowe and E.R. David E. Waite, and Past Grand Est. Lecturing Knight J. Theodore Moses.



P.D.D.'s James J. McCarthy and Owen Keown were General Co-Chairmen of the festivities at which the two surviving members of the first class initiated after No. 906's institution, Leon Mooser and R. J. Haney, represented the two Charter Members of the lodge both of whom had passed away just a few weeks prior to the celebration.

## Midwest City, Okla., Elks Form a Perfect Friendship

Midwest City Lodge No. 1890 asked the City Council for permission to take over and develop Friendship Park which had been turned back to the city by the Odd Fellows Lodge. The offer was accepted from Elk Jack Guthery, who stated that

the lodge would spend \$1,200 a year on the development and maintenance of the Park, even drilling a well, if necessary, to keep the area in condition. As a result, Midwest City's Friendship is now known as Elks Park.

These generous members of the Order have made another fine civic gesture. Learning that the parents of the local Senior High School Band members were looking for the ways and means to purchase 70 coveralls for the youngsters, to save wear and tear on their uniforms, No. 1890 promptly voted to take over the entire expense. E.R. Roy Gonders presented a \$399 check to Band Parents Club Pres. E. W. Orr in the presence of School Principal J. E. Sutton, Jr., and Band Director Lyle Work. At this writing 70 handsome white coveralls, suitably lettered in gold, are being sported by the grateful bandmen.

## El Dorado Elks' Midgets Are Kans. Diamond Giants

The team sponsored by El Dorado Lodge No. 1407 took the State Championship when they blasted the Manhattan entry 7 to 3 in the final contest of the highly exciting 4th Annual Kans. Elks Assn.'s Midget Baseball Tournament. Staged on the victor's home grounds, the competition attracted greater interest than ever before recorded.

The talented youngsters, all under 14, came to El Dorado uniformed by the Elks of their respective cities. Visitors were housed in a community building near the Central Park Stadium, scene of the meet, and cots were provided by the Wichita American Red Cross Chapter, and other cooperative individuals.

Between their diamond appearances, the boys were entertained at local movie houses as guests of the host lodge. Three competent umpires were engaged to handle the four-day, single-elimination.



Above: Lt. Col. Thomas P. Dickinson, second from left, Pres. of the United Cerebral Palsy of Virginia Peninsula, Inc., and a member of the Order, presents a citation for humanitarian service to E.R. Clyde A. Cottrill of Hampton, Va., Lodge. At left is P.E.R. B. L. Saunders, UCP Director, and at right is State Vice-Pres. Francis J. Howard. Hampton Lodge liberally supports the Peninsula Cerebral Palsy Training Center, and sponsored one of its occupational therapists, Miss Beverley J. Gaines, who received an Elks National Foundation grant for advanced study at the Children's Rehabilitation Institute.



Below: Members of Springfield, Mass., Lodge's Youth Committee place one of the safe-driving stickers they provided for 2,000 cars during the opening week of the school year. Foreground: Mayor D. B. Brunton, left, and E.R. Charles M. Nolan; standing, Chairman G. W. Lafleur, left, and Police Sgt. J. A. Murphy, a member of the Committee.



Above: This scene was photographed at Charleston Lodge when a class was initiated in honor of D.D. Curtis A. Hill. One of the candidates was Dr. Jose Sansaricq, the 10,000th Ill. S.E. Dist. Elk. Left to right, foreground: State Vice-Pres. John Mitchell, Dr. Sansaricq, host E.R. Gerald Baker and State Pres. R. G. Borman. Standing: D.D. Hill, P.D.D. Dr. R. H. Griffiths and State Trustee George W. Wenthe.

event, all details efficiently supervised by lodge Secy. F. P. Neumann as Tournament Manager.

Coached by Elk James McDonald, the El Dorado youngsters are the first team to capture two of the four tournament titles; their first success took place in Abilene in 1952. Twelve teams participated this year, with the Wellington contingent in third place over Topeka; all four semi-finalists were awarded handsome trophies.

#### **Willimantic, Conn., Elks Hold Two for One**

When D.D. Aubrey H. Brown paid his official visit to Willimantic Lodge No. 1311, the event coincided with the lodge's Father and Son Night, with about 50 of the lodge's 120 junior-senior family com-

binations on hand. Highlight of the program was the initiation of a class in Mr. Brown's honor, with E.R. Alexis Caisse, Jr., conducting the ritual for the embryo Elks, one of whom was his son, Norman. Among the other initiates were Homer and Robert Roy, a new father and son combination for No. 1311.

During the lodge session, these Elks voted to assist in sponsoring the attendance of a high school student at the F.F.A. Convention in Kansas City.

#### **Galveston, Tex., Mourns William Alonzo James**

William Alonzo James, P.E.R. and Chaplain of Galveston Lodge No. 126, passed away several months ago, after a lingering illness. A member of Galveston Lodge since 1902, he had been a

prominent and active participant in its affairs, as well as in the State Elks Assn. He had also served as District Deputy.

Born in 1865, Mr. James, affectionately known as Jimmie during his 44 years on the faculty at Ball High School, was widely known as a world educator. A member of the committee representing the National Education Assn. at five sessions of the World Federation of Education, for 15 years he had served on the commission for higher institutions for the Southern Assn. of Colleges and Secondary Schools, and for seven years in the Junior College Division.

A bachelor, Mr. James devoted his entire lifetime to the interests of youth. To his sister, his brother and his thousands of friends, the Magazine staff extends its sympathy.

Dignitaries standing at left background overlooking the crowd at Santa Monica, Calif., Lodge's Golden Jubilee Banquet include State Trustee Owen Keown, Hon. Thurlow Taft, City Councilman Jack Guercio, State Pres. R. P. Mohrbacker, D.D. F. E. Tumbleson, Rev. C. E. B. Nobes,

Past Grand Exalted Ruler L. A. Lewis, E.R. M. R. Caruso, Co. Supervisor H. B. Chace, Rev. Msgr. R. J. O'Flaherty, Past Pres. R. L. Bush, P.D.D. J. J. McCarthy, U. S. Marshal R. W. Ware, Hon. A. T. Lynch, School Supt. Dr. M. E. Morgan, high school principal Dr. Ewing Konold.







Above: Pictured at their annual fall dinner party are the Past Exalted Rulers of Alexandria, Minn., Lodge, with current E.R. Joe G. Thornton, standing at left, and P.D.D. Norman Hansen, seated at left.

Left: About 100 children from the Boys Opportunity Home and the Girls Welfare Home were guests of Decatur, Ill., Lodge at its annual picnic. Heinie Schulte, center, has directed this affair for the lodge for 14 years, and handled it on his own for ten years prior to that.



This is the "Holso" bowling group which won the 1954 Championship of Ashtabula, Ohio, Lodge's 30-team League. Left to right, foreground: Geo. Mackey, Capt. T. J. Holso and Chet Thompson; background: Vic Karhu, Bob Anderson, Fred Johnston and Alec Torok, Sr.



Chillicothe, Ohio, Lodge's 1954 Midget Baseball Team closed the season in second place in its league, entered the National Knot-Hole Tournament in Cincinnati with 26 teams from seven States. Standing in the background are E.R. C. R. Cline, left, and Mgr. and Coach Russell Friend.

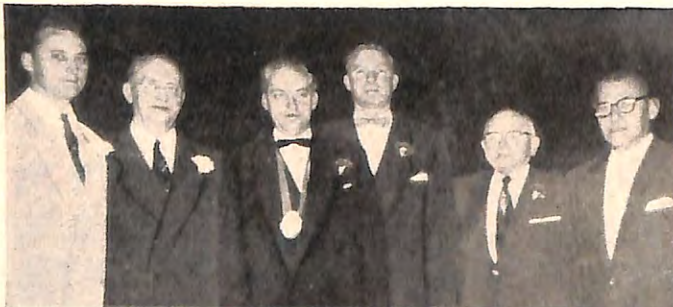

Left: When State Pres. Ralph Bastian visited Sioux City, Ia., Lodge recently, E.R. C. E. Pierce and his officers initiated a State President's Class, two of whose members were the father and brother of E.R. Pierce. Left to right: L. F. Pierce, Jr., and Sr., E.R. Pierce, Mr. Bastian and Past State Presidents A. R. Perasso and Frank J. Margolin.

Below: Pictured during the official visit of D.D. Andrew D. Mapes, standing fifth from left, with the officers of Omaha, Neb., Lodge, are the members of the class, seated, initiated in Mr. Mapes' honor.

### All Alexandria, Minn., P.E.R.'s On Tap

Ever since it was instituted in 1946, Alexandria Lodge No. 1685 has held an annual fall dinner party for its former leaders and their wives at a nearby beach resort. This year's affair was a distinct success, primarily because of the unusual fact that every one of No. 1685's P.E.R.'s and their wives were present, as well as its current E.R. Joe Thornton and his wife.

During the meeting, this group made plans for the opening social gathering of the fall season when it is the tradition for the 330 Alexandria Elks and their ladies to be the guests of the P.E.R.'s at a gala and always popular affair.





# News of the State Associations



William J. Jernick, the Order's current leader, center, with Past Grand Exalted Ruler L. A. Lewis, right, and retiring State Pres. Edward E. Keller, admires the magnificent floral tribute to Elkdom which was displayed in San Francisco's Golden Gate Park throughout the Calif. Elks Assn. Convention. Thousands of colorful potted plants formed the famous Elk Emblem in a design executed by the Park and Recreation Departments of the City and County of San Francisco.

## Tennessee Elks Convene

Knoxville Lodge was host to the three-day 14th Annual Convention of the Tenn. Elks Assn. in Sept., when retiring Pres. S. J. Elkins, Jr., presided. Host E.R. Allen J. Bell, Jr., County Judge Howard Bozeman and Mayor G. R. Dempster welcomed the 441 delegates, with Past Pres. Edward W. McCabe, Chairman of the Grand Lodge Ritualistic Committee, making a gracious response. Grand Treas. Robert G. Pruitt was the principal speaker at the banquet, and P.E.R. Dean Douglass of Memphis delivered a moving Memorial Address. Hugh W. Hicks of the Grand Lodge Pension Committee, D.D.'s Earl Broden and W. J. Barron, and Past Presidents Albert Heins, E. J. Nunn, J. R. Reed and J. J. Farrell were also on hand.

Seven lodges competed in the Ritual-

istic Contest, with Nashville emerging as victor. Many interesting reports covered the Assn.'s activities, including its Hospital Committee work on which \$6,050 had been expended during the year which saw a 400 net membership gain, two lodges instituted, and a third coming into being immediately following Convention adjournment.

Until the 1955 Convention in Memphis, the following will hold office: Pres., Maurice Conn, Bristol; Ranking Vice-Pres., Jack Armstrong, Columbia; Dist. Vice-Presidents: J. A. McConnell, Kingsport; G. H. Dykes, Oak Ridge; Ernest Goldstein, Paris; Trustee (three years) Thomas Stratton, Nashville; Treas., John Menefee, Chattanooga; Secy., H. T. Parrish, Bristol; Tiler, George Farr, Chattanooga; Sgt.-at-Arms, Dean Douglass, Memphis; Chaplain, Rev. Pickens Johnson, Nashville.

## 5,000 Hear Major Project Report at California Convention

The 40th Annual Reunion of the Calif. Elks Assn. in San Francisco Oct. 6-9, was attended by nearly 5,000 delegates and ladies, most of whom were on hand at the Civic Auditorium for the special reports of the Major Project and Veterans Service Committee and for the moving Memorial Services and an inspiring Festival of Music.

The report on the Major Project showed tremendous benefits to 300 cerebral-palsied and other physically-handicapped children accomplished through the State-wide effort spearheaded so vigorously in 1950 by Past Grand Exalted Ruler L. A. Lewis.

Committee Chairman Horace R. Wisely introduced to the audience the 11 therapists in charge of the Assn.'s four mobile units, comprised of 11 specially equipped station wagons which operate in four remote areas of the State, visiting homes of afflicted children and training parents to help the youngsters by administering therapeutic aid. Remarkable results have been noted within a year, or less, and as living proof Mr. Wisely presented a young boy whose body had been so badly misshapen with muscular dystrophy that his torso was bent to one side and his head was immobile; after a few months' instruction on the part of the therapists, this child faced the audience, erect in his wheel chair, eyes bright, head held high. Another youngster who had never been able to walk until the Calif. Elk specialists took him over, came to the stage alone with the aid of braces and special crutches, and walked the entire length of the platform, to be lifted to the microphone to speak personally to his benefactors.

Miss Margaret Rood, in charge of the mobile unit at Indio, is developing a new therapeutic technique which has attracted so much attention that she was invited to address the National Convention of the American Physical Therapy Assn. on that subject. Her concept has been approved following tests at the Univ. of Ind. Medical Center, results of which will be revealed shortly in the medical journals and a textbook she is preparing for publication.

Chairman Wisely stated that the Piggy Bank idea originated by Past Grand Exalted Ruler Lewis had produced \$80,000 in a six-month period. This is in addition to special lodge events suggested by Past Pres. Vincent H. Grocott, and other donations which have realized a sum of nearly \$45,000. While combined receipts totaled \$231,903.23, Mr. Wisely pointed out that additional sources of revenue must be found if the Committee's work is

(Continued on page 36)



Retiring Pres. S. J. Elkins, Jr., right, presents the gavel to his successor, Maurice Conn, left, at the Tenn. Elks Convention. Looking on are Grand Treas. Robert G. Pruitt, third from left, and State Assn. Treas. John T. Menefee.



# ROD & GUN

BY DAN HOLLAND

**Patience also pays off when you are deer hunting.**



TWO PICTURE whitetail heads—twelve points each and perfectly proportioned—decorated the wall of the room where we sat. I had stood and admired them a hundred times or more when I had been in Harry Leonard's home, and now I was gazing at them enviously again. Someday, if I hunted hard enough, I thought to myself, I might get a crack at a deer like that.

It was a gray November day outside with a light, damp snow falling, giving the ever-changing Vermont hills a fresh whitewash job over the dying colors of autumn.

"Perfect tracking snow," I commented, glancing out the window. "Once I stayed with a big buck for six hours in a snow like this. I jumped him several times, but never saw him to get a shot."

"How did you know he was a buck if you didn't see him?" Harry asked.

"By his tracks, of course," I answered. "His feet were big, his toes were blunt and pointed out, and he dragged them as he walked."

"Maybe," Harry remarked. "Maybe, and again maybe not." He relit his pipe, took a couple of puffs and commenced talking. "Puts me in mind of a couple of hunters I met up behind Thistle Hill on a day something like this a few years back. I had taken a stand alongside a pretty good run, sitting on an old beech log. Been there about an hour, I'd say, when along came three deer, one big doe and two small ones. Right behind them two hunters came crashing along puffing and blowing. They didn't see me, of course; they were too busy looking down at the tracks and jabbering about them."

"Looking for something?" I asked.

"How long have you been here?" one of them asks when he gets his wits about him.

"Not long," I answered.

"Should have been here a minute sooner. A big buck just went through."

"How do you know?" I asked.

"Look at those tracks!"

"I looked and asked again: 'How do you know?'"

"Look at them, that's how. Any fool can tell a buck track when he sees it."

"I bent over and looked close. 'Guess

you're right,' I admitted. 'Yep, that's a buck all right. Good one.'

"You know this country," said the hunter anxiously. "Where will they go?"

"I laid out about a four-hour hunt for them, wished them luck and went back to my log. They took off almost at a run, breaking down the brush as they went. I could still hear them when they rounded the hill. That evening I saw what looked like the same three does. I didn't wait for the two hunters to show up, but I imagine they were dragging along plenty far behind."

"You know," he went on, "I've shot a few deer in my time, but I never killed one tracking him—unless he was already wounded, of course."

I thought about the pile of old antlers out in the corner of Harry's barn, and I realized I had just learned something worth putting under my hat.

"Didn't you ever have any luck circling

them?" I asked, still not quite satisfied.

"Sure, I've circled and got ahead of them," he answered, "and scared them to somebody else. About all that the trackers, circlers and brush-breakers do is give the other fellows some shooting."

Eastern States deer hunting is a species of big-game hunting all its own. In a few out-of-the-way spots in New England it is possible to get back where a hunter can stake his skill against the deer without outside interference, but for the most part in the East there are numerous other hunters in the vicinity who may enter the picture as aid or obstacle, as the case may be. As a rule, it is the patient hunter, the fellow who sits on an old beech log, who eventually hangs a buck. I had learned that much at least.

This condition—many hunters in comparison to the number of deer and available cover—is so exaggerated in some localities that getting a deer would seem to be a matter of luck entirely; however, this is not entirely so. Even in New Jersey where armies of hunters

*(Continued on page 43)*



Dan Holland hangs up the Thanksgiving deer in his Vermont barn.





*A Christmas Message  
from the Grand Exalted Ruler*

**T**HE spirit of Elkdom reflects the true spirit of the Christmas season. The finest and best in man rises to the surface at this festive time, and man achieves his divine potentialities, for these are the days of benevolence, of brotherhood, of peace and good will.

We Elks are dedicated to the expression of these qualities. This is the time of year when we ought to renew our pledge of faith in mankind. That faith will lead us to charitable thoughts and deeds, to harmony wherein all men seek ways of assuring the progress of civilization toward peace and love.

Whatever our religious affiliations, we as Elks recognize one God whose children we are. This belief has found expression in our practiced principles of charity, justice, brotherly love and fidelity which assume even greater reality at this time of year.

This season of reverence for God, of sparkling lights, of gaily decorated homes, of candle glow, of reunion with loved ones should inspire us to rededicate our lives to service to others; the kind of service that brings with it actually and factually the betterment of our communities, our states, and thus our nation; the kind of service that will fully achieve our lofty purposes. *Let us not put this reverence and love away with the holly wreaths and the Christmas tree ornaments for another year.*

Let the rays of the Christmas star, the light that glows in the eyes of little children, the brilliance that shines from happy faces be a beacon to light our way through the year. Let love and charity and brotherhood and good will light our activities all during the days and years ahead so that Elkdom may be a candle to illumine the way for the lost, a flame to warm the lonely, and an everlasting star shining upon men of good will.

It is my sincere wish that the joy and peace of Christmas shall be with you and yours now and through all the days and years ahead.

*William Jernick*

WILLIAM J. JERNICK, GRAND EXALTED RULER

★ *Gold Star Certificate Program No. 4. Most appropriately at this Season is the Grand Exalted Ruler's objective to have all 1,700 lodges participate in some form of charitable and community welfare work.*



# ANOTHER PAGE FOR YOUR ELK FAMILY ALBUM



P.E.R. Thomas P. Golden, left, foreground, congratulates George R. Bryans, a San Diego, Calif., Elk, right, on bringing into the Order his father and four brothers, pictured in the background.

Left: Past Grand Exalted Ruler John R. Coen, center, welcomes Thomas A. Rapp, Jr., left, son of 36-year-Elk Thomas A. Rapp, Sr., right, into Greeley, Colo., Lodge, in the presence of the young man's two Elk brothers, Harry, second from left, and Stanton, second from right. At the last three initiations of Greeley Lodge conducted during the administration of E.R. Ross I. Shaklee, three Elk sons were initiated—the E.R.'s son, George Shaklee; M. E. H. Smith, Jr., son of Grand Lodge Committeeman Smith, and Robert W. Stanley, son of A. E. Stanley.



During the Oregon Convention, the father and five-son Stewart family of Elkdom was photographed. Left to right: P.D.D. Lee Stewart and Est. Loyal Knight Chester Stewart, Jr., both of The Dalles Lodge, and Walter, Chester, Sr., Donald and Darrell Stewart, all of Tillamook Lodge. Donald is wearing the uniform of that lodge's Drum and Bugle Corps.



P.E.R. Jack Johannsen, second from left, congratulates Fred E. Scoggins, one of the four sons of John F. Scoggins, Sr., second from right, who were initiated into Augusta, Ga., Lodge at the same ceremony. The other new Scoggins Elks are also pictured—Preston L., left; Franklin M., third from left, and John F., Jr., right.



During his term as Exalted Ruler of Seattle, Wash., Lodge, Tracy Call, center, initiated his brothers, Roy L., left, and Boyd H. Call.



On Old Timers Night at Adams, Mass., Lodge, P.E.R. Wm. A. Baker, standing fifth from right with other dignitaries who officiated, brought his fourth son into the Order. The younger Elks in this family are, seated left to right: William W., Robert C., Donald A. and Earl E. Baker.



Norwich, N. Y., Lodge has three family groups. Above, left to right, are J. F. Shetron, a recent initiate; his brother, Esq. Donald O. Shetron, and their father, Orrin, another initiate. At right: L. W. Phelps and his son; P.E.R. P. F. Koot, center, and H. L. Wilson, Jr., and his father.







At the institution of Keyser, W. Va., Lodge, the fifth member of the Mackert family was initiated, joining the Fraternity of his father and three brothers, all Cumberland, Md., Elks. Left to right: Joseph E.; Robert F.; Joseph A., the father; P. William, and Thomas E. Mackert.



History repeated itself at Eureka "Tintic", Utah, Lodge when P.E.R. Maynard Griggs brought his son Ronald into the Order, just 28 years after his own initiation. Left to right are E.R. James F. Hannifin, Mahlon Rasmusson, another initiate, and Ronald and Maynard Griggs.



E.R. T. M. Oettinger of Waukesha, Wis., Lodge, right, with fellow Elk Scott Kennedy, second from right, and his sons, William, Leslie and Irving Kennedy, on the occasion of the younger men's initiation.



On Newark, N. J., Lodge's P.E.R.'s Night, Daniel V. Crosta, seated left, initiated his son William, seated right, in the presence of his two other sons, Donald and Robert, also members of Newark Lodge.



Right: Alphonse Zito, seated center, was honorary Chairman for the program during which his four sons were initiated into Attleboro, Mass., Lodge. The young men who received membership pins from their Elk father are, seated, Raymond and Michael, and, standing, Ralph and Philip Zito.



Charter Member Frank W. Hawley of West Haven, Conn., Lodge, second from left, congratulates his son Frank E. Hawley as E.R. of the lodge in the presence of another Elk son, William Robert Hawley, third from left, and P.E.R. R. G. Wilde, left, and Secy. G. H. Scott, P.D.D.



E.R. Floyd W. Bombard, center, and the Jones brothers who were initiated into Terre Haute, Ind., Lodge in the same class. The new Elks are, left to right: Alfred V., Coyt H., Robert M. and Delmar L. Jones.



Carl Ramberg, center, 12-year-member of Havre, Mont., Lodge, saw his four sons initiated at the same ceremony. Left to right, they are Clarence E., Lawrence R., Harold A. and Clifford V. Ramberg.



## LODGE NOTES

The only half-century members of the 1,000-Elk Kankakee, Ill., Lodge were honored recently when Shirley Moisant and V. G. Beedy received 50-year pins at a special program. On the same occasion, citations were presented to a number of members who successfully managed the lodge's Youth Pony League this year; another highlight was the initiation of a class as a tribute to D.D. Stewart Strain.

D.D. H. Philip Barney made his first official visit to Detroit, Mich., Lodge and witnessed the initiation of 25 candidates. The social part of the program included a dinner and floor show. Incidentally, Detroit Lodge will be host to the 1955 Elks Natl. Bowling Assn. Tournament on weekends from Mar. 26 through May 15. Interested keglers are reminded to make reservations NOW through Assn. Secy. Edgar N. Quinn, P.O. Box 29, Madison 1, Wisconsin.

Rockland, Me., Lodge has a Secy. who offers a challenge to all Brother Elks holding this office. In his twenty-year tenure, Joshua N. Southard has missed only one meeting of his lodge—and that's a mighty hard record to beat.

Twenty new United States citizens were welcomed at a stirring civic ceremony held at the home of Casper, Wyo., Elkdom recently. John Hendrickson, National Director of the Junior Chamber of Commerce, was the principal speaker and Walter Kingham was on hand to represent the Mayor at the program for which Frank Dolenc was Chairman.

Approximately 300 Elks and their guests attended the Freehold, N. J., Elks' first clambake not long ago, when fried chicken and other delicacies were provided for non-clam-eaters. Harry Andrews and his orchestra entertained at the bake, as well as at the lodge home later on.

For the second time in three years, Mountain View Union High School in Palo Alto, Calif., has as its guest a student from the Ulrich von Hulten Schule in Berlin, Germany—16-year-old Ulrich Mohrmann, here on the Exchange Student Program of the American Field Service. The young man is in this country largely through the assistance of the local Elks who have assumed the major portion of the Mountain View Affiliation Club's financial burden.



Here are the successful entrants in the 6th Annual Southeastern Elks Golf Tournament played at Meadowbrooks Country Club in Atlanta, Ga., with golfers from Virginia, Alabama, No. and So. Carolina, Florida, Tennessee and Georgia participating. The Haygood-Tolbert Team Trophy winners are the four Cascade, Ga., Elks in the foreground, holding their individual trophies.

### Losers Share Spoils of New Bedford, Mass., Elk Diamond Stars

The Annual Banquet of the Pony Baseball League of New Bedford Lodge No. 73 saw 425 players, parents and friends pleasantly entertained.

Climaxing their third season of sponsorship of the second largest Pony League set-up in the United States and Canada, the Elks presented numerous awards to teams and individuals through the good offices of Commissioner William J. Joyce, P.E.R. Most of the honors went to members of the championship Exchange Club team whose Manager, Ossie Fredette, and Guy Camuso of the second-place Rotary Club group also received trophies. Asst. Commissioner Joseph St. Onge acted as M.C. for the program at which E.R. Robert M. Lumiansky read a message from National Pony League Commissioner Joe E. Brown. Others present included Mayor and Mrs. Arthur Harriman, lodge Secy. Morton G. Sartoris, P.D.D., and many other Elk, civic and newspaper officials.

### Lockport, N. Y., Elks Make Sunshine

On the afternoon of the first Wednesday in August, members of Lockport Lodge No. 41, with a caravan of cars carrying

200 underprivileged youngsters, leave their home for the amusement park at Olcott. Escorted by local police and State Troopers, the children, all residents of the Wyndham Lawn Home, Niagara County Preventorium or the Niagara Sanatorium, sing their way to the park where they are amused by entertainers brought in by Ray Kneeland, and enjoy themselves on the traditional carnival "rides" on the Bert Flynn Midway.

This is Lockport Lodge's annual Sunshine Day, inaugurated nearly 30 years ago by a group of local Elks, one of whom was P.E.R. Adolph Kudel, this year's Honorary Chairman. Hubert Flynn and his son are owners of the Olcott Beach Amusement Corp., and have donated the privileges of their midway to the Elk guests for many years. At the height of the most recent day's festivities, Mr. Flynn and Ray Kneeland received Life Memberships from E.R. Arnold W. Hautala in recognition of their untiring efforts through the years to make this Sunshine Day the success it always is.

After the rides close down, the Elks and their wives who help keep an eye on these youngsters see that their charges have all the food, ice cream and chocolate milk they can handle, then bundle them into the cars again and return them to Lockport.



This is the Midget Baseball League Team sponsored by El Dorado, Kans., Elkdom. Under the coaching of Elk James McDonald, left, these youngsters captured the State Championship.





Above: This is Verona, N. J., Lodge's baseball team which won the Caldwell Junior League Championship and participated in a special exhibition game to raise funds for the polio drive under the coaching of E.R. Grover Kayhart. The lodge also sponsors a Midget Baseball League Team and a group in the Cedar Grove Junior Baseball League.

### San Diego, Calif., Lodge Judges Judicial Night a Success

One of the outstanding events in the history of San Diego Lodge No. 168 was this year's Judicial Night when more than 125 local attorneys and twelve jurists of the local courts joined 100 members of the lodge in the annual event.

A cocktail hour preceded a banquet after which an open meeting was held with E.R. Claude B. Brown and all lodge committee chairmen enlightening their bench and bar guests on the many charitable and community welfare activities of the lodge and the Order. The jurists returned the compliment with stories of their experiences in court.

P.E.R. Edgar B. Hervey, former State Vice-Pres., emceed the affair, assisted by Co-Chairmen Harry Ragen and Robert O'Connor.

### Ridgefield Park, N. J., Elks' Boys Play Over .850 Ball

During the late-lamented baseball season, the members of Ridgefield Park Lodge No. 1506 sponsored a Little League team which won the city championship by taking 12 of its 14 scheduled games. These youngsters have a flair for putting on an exciting show; at the close of the season they played the Red Bank Elks' team to a 2-2 tie, and a return match ended in another tie. In the county championship play-offs they were eliminated during their third contest in a thrilling ten-inning game they lost by only one run.

Est. Lead Knight W. H. Buron, Chairman of the lodge's Youth Activities Committee, was in charge of the youthful sportsmen who were awarded handsome satin jackets by their sponsors and, with their parents, were entertained at the lodge home.

### Illinois S.E. Welcomes Its 10,000th Elk

Not long ago the officers of Charleston Lodge No. 623 initiated a class in honor of D.D. Curtis A. Hill. Among the candi-

dates was the 10,000th Elk of the Ill. S.E. Dist., Dr. Jose Sansaricq. Representatives from many lodges of the area, as well as Dist. officers and committee heads, were on hand.

Radio stations from four Illinois cities—Mattoon, Clinton, Olney and Fairfield, carried a simultaneous 15-minute broadcast of the addresses made at the

dinner which preceded the meeting. Among the speakers were Charleston Lodge's E.R. Gerald Baker, D.D. Hill, Dist. Vice-Pres. John Mitchell, State Pres. R. G. Borman who was an unexpected guest, and the 10,000th candidate. Other dignitaries present included Dist. Trustee George Wenthe and P.D.D.'s John Osborn and Dr. R. H. Griffiths.



Below: Pictured at the home of Towson, Md., Lodge on the occasion of the official visit of D.D. Rosell T. Pickrel are, seated left to right: P.D.D.'s Daniel Sullivan and Ambrose A. Durkin, Mr. Pickrel, P.D.D. Andrew J. Kessinger, Past Grand Exalted Ruler Joseph B. Kyle and P.E.R. Lawrence E. Ensor; standing: P.D.D.'s N. Bosley Hoffman and R. Edward Dove, host E.R. J. Wm. Hughes and P.D.D. Edgar J. DeMoss.



The 24-man 65th Anniversary Class of McKeesport, Pa., Lodge with E.R. J. F. Lewis and his officers, D.D. Fred N. Reno, State Vice-Pres. Walter Urben, 50-year-members Dr. G. P. Gamble and J. A. Pierce, both P.E.R.'s, and former Grand Lodge Credentials Committee Chairman L. M. Lippert.



Chairman Edwin J. Alexander of the Lodge Activities Committee of the Grand Lodge, second from left foreground, congratulates E.R. J. P. Head of Pasco, Wash., Lodge on the initiation of this outstanding 167-man class. Third from left foreground is D.D. Leslie I. Brecke.





On the 93rd birthday of 48-year-member Charles Weiside, the officers of Portland, Ore., Lodge, foreground, led by E.R. E. J. Nelson, center, initiated this 49-man class in his honor. On E.R. Nelson's left is Mr. Weiside; on his right is Past Grand Exalted Ruler Frank J. Lonergan.

**McKeesport, Pa., Elks Give Three Days to Triple Celebration**

A gala three-day program, climaxed by the initiation of a 24-man class in honor of D.D. Fred N. Reno, marked two anniversaries of McKeesport Lodge No. 136—its 65th year of existence and 50th year in its present home. The events also celebrated the formal opening of the newly remodeled lodge rooms.

Opening with a Stag Night program attended by hundreds of local and visiting Elks, the festivities included open house for members and their wives the following evening, and closed with the formal anniversary program handled by a committee headed by E. F. Siwec.

**Amherst, N. Y., Lodge Instituted**

Under the sponsorship of Buffalo Lodge No. 23, Amherst Lodge No. 1942 came into being recently at ceremonies



Below: Pictured during D.D. Everett E. Palmer's visit to Bismarck, N. D., Lodge are Mr. Palmer, P.D.D. J. S. Fevold who introduced him, the lodge officers and the 20-man D.D. Class.

conducted by James A. Gunn of the Grand Lodge Committee on Lodge Activities, assisted by Past Grand Est. Lect. Knight J. Theodore Moses.

About 250 Elks attended the affair, directed by Special Deputy Gordon B. McKay and held at the Buffalo Trap and Field Club. Officers of Lancaster Lodge

No. 1478 handled the initiation of the Charter Members, with the sponsoring lodge leaders acting as Marshals. The installation of E.R. David E. Waite and his corps of officers was also handled by Mr. Gunn and Mr. Moses, with the assistance of D.D. John Bottorf, P.D.D. Erwin E. Hamman and Mr. McKay.



Above: Over 300 persons attended the testimonial dinner given in West Haven by the Conn. Elks Assn. as a tribute to Past Grand Exalted Ruler George I. Hall, pictured fifth from left as he accepted several gifts from State Pres. Thomas F. Winters, third from left. On Mr. Winters' right is James A. Gunn of the Lodge Activities Committee of the Grand Lodge. Others are Arthur J. Roy, former Chairman of the Grand Lodge Ritualistic Committee, right; Past Pres. Samuel M. Annunziato, Dinner Chairman, center; Program Chairman Clifford H. Whitehead, second from right, and Harry J. Kenney of West Haven.

**A NOTE ON MEMORIAL AND CHRISTMAS REPORTS**

To insure complete understanding of the procedure for reporting Memorial Sunday and Christmas charity programs, to be considered for award by the Lodge Activities Committee of the Grand Lodge, remember that Joseph F. Bader, 279 Traversers Place, Lyndhurst, N. J., must have your Memorial Services material NO LATER THAN DECEMBER 17th.

Christmas charities, and similar Thanksgiving events, should be reported to Thad Eure, State Capitol, Raleigh, N.C., by JANUARY 14th, AT THE LATEST.

Do not delay matters by sending these reports to the Magazine office.

Below: Bluefield, W. Va., Lodge sponsors one of the four teams in the local Junior Football League. This photograph was taken when the entire group and their cheerleaders were guests of the lodge at a hot-dog roast. In the background are E.R. E. H. Tucker, Est. Lead. Knight W. S. Penn, Jr., and Daniel S. Davis, Coach of the Elks' team.







## TOM WRIGLEY WRITES FROM WASHINGTON



**A**S THE Christmas shopping season arrives United States Treasurer Ivy Baker Priest informs this reporter that there is plenty of money in circulation. Who's got it is another matter. There is, however, around \$30 billion on the loose as legal tender and held in the Treasury is about \$54 billion more. Most of the \$30 billion in circulation is folding money and Mrs. Priest's signature appears on every greenback issued. It's a neat one, too, and looks just the same on the dollar bills as on the \$10,000 beauties. It is positively denied that Thomas Jefferson's picture was put on \$2 bills because as a true Virginian he liked horses. As a matter of fact, Mrs. Priest says the two dollar bills are in use in a lot of places outside race tracks. Over \$70 million two dollar notes are in circulation and half of them are in the New England area. Silver dollars so widely used in the West total over \$216 million. Another \$90 million are stacked in the Treasury. As for silver bullion, the total is over \$2 billion. The Treasury calls small change "minor coin" but it's no chicken feed when it totals over \$419 million in circulation, with more than that amount in the Treasury. That means over \$2.50 of small change in circulation for every person in the country. Getting into important money, more than \$9.5 million in 20 dollar bills are in circulation. One hundred dollar bills are popular too, in a total amount of about \$5.5 million dollars. Some folks like to keep one or two just to show off. There are not so many 10,000 dollar bills; only \$7.7 million of them. And Mrs. Priest says there are such things as 100,000 dollar bills, but used only in the Federal Reserve System and never going places in circulation. As for those one dollar bills which disappear so rapidly, there are about \$2.2 billion going in and out of pockets and cash registers.

### TERRAPIN COMEBACK

Back in the days of horse cars, diamond back terrapin was a famous and expensive dish along the Potomac waterfront. It takes all day to cook terrapin a la Maryland and in recent years the exclusive Maryland Club of Baltimore is one of the few places where it is served. At last, however, a move has been made to get terrapin back on the tables of Washington's restaurants. Down at Cris-

field, Md., experiments are being made in a special sea food laboratory to process terrapin in various ways for easy shipment and sales.

### WASHINGTON IN MOVIES

Washington is being used more and more by movie producers as background for feature films. The Capital's government departments, buildings, parks and shrines are ideal for the cameraman. Here, too, in old Georgetown and in other localities are historic houses and churches dating back to the stirring days of the Revolution. Top men of the Armed Services as well as heads of agencies and bureaus are usually glad to cooperate in movie production. It's good public relations.

### WOODROW WILSON'S HOME

Mrs. Edith Bolling Wilson, widow of former President Woodrow Wilson, lives at 2340 S St. N.W., where they lived after leaving the White House and where he died February 3, 1924. The house has been given by Mrs. Wilson to the National Trust For Historic Preservation as a memorial but will not be opened to the public while she continues to make it her home. It has many historic furnishings. From the portico on Amistice Day, 1923, Mr. Wilson made his last public appearance. Many visitors to Washington visit the home, just to look at the entrance and get a glimpse of the terraced garden in the rear where Woodrow Wilson, World War I President, spent his last days.

### GG SALES ORDERLY

Removal of restrictions by the Office of Defense Mobilization on sale of gamma globulin produced no complications in the fight against polio. ODM officials point out that the peak epidemic season has passed and, furthermore, the National Foundation For Infantile Paralysis is ready to give inoculations for free in the case of any outbreaks. GG provides protection against paralytic polio for upwards of six weeks.

### NEW FEDERAL PROBE

Exposure of a secret order to investigate the conduct of all government workers has created a behind-the-scenes upheaval in federal employment circles. The directive, issued by the Budget Bureau, was kept a close secret for four

months. Messengers delivered it personally to heads of all executive departments and establishments. It orders an investigation of government workers and has been labeled, "snooping" and a federal "gestapo." High government officials, finally making the directive public upon demand by newspaper reporters, insist it only supplements other investigative procedures and will not probe the private lives of employes. Civil Service Commission, it is reported, objected to the "vagueness" of the order and just what is meant by investigating the "conduct" of the workers. Government employes themselves are at a loss to understand the reasons back of the probe, since they already are carefully screened and graded.

### JET PLANES

All American fighter planes are now jets and over 85 per cent of Air National Guard fighter wings are jets. The day of giving the National Guard a lot of cast-off junk and expecting it to be efficient is over.

### CAPITAL CRISPS

Police Chief Murray of Washington says the gold braid on the caps of officers is too heavy and wants the "scrambled eggs" taken off . . . People still get in trouble with the Food and Drug Administration by falsely advertising stuff to grow hair on bald heads . . . The price of that "Infant Care" booklet issued by the government has now been upped to 25 cents, with total sales now over 33 million . . . Smithsonian Institution has acquired a dugout canoe from the Seminole Indians of the Everglades in Florida because the art of making them is almost lost . . . Washington spends \$1.60 a day to educate each pupil, or 12 cents above the average for big cities . . . Scientists are working on a radio buzzer or bell which can be installed in homes in atomic bomb areas and set off by remote control as a warning to vacate . . . CD Administrator Val Peterson says it will take two years before a system of detecting bombers will give adequate warning to big American cities for evacuation of inhabitants . . . The sign said "Carry Out Shop" so when the proprietor returned he found a newly hired clerk had carried out \$190 without even leaving a note saying "thanks."



# FOR ELKS WHO TRAVEL



**For a new kind of vacation without neon lights and crowds, try one of the little known islands of the West Indies.**

**BY HORACE SUTTON**



## HEADING FOR THE JERSEY SHORE?

While on the way stop and relax at

**MILLVILLE, N. J., B. P. O. ELKS**

Here is the Gateway City to most South Jersey Coastal resorts. You'll find Millville No. 580 a restful place to linger awhile. No overnight accommodations in the Lodge but you can get tasty snacks and a refreshing shower. There's a powder room too and grill and recreation rooms plus a sumptuous lounge. Cocktail hour Monday through Saturday 4:30 to 6:30 P.M. Your welcome here will be cordial and we'll try to make your journey a happier one.



## While on Your way through Indiana—

Stop off at Peru B. P. O. Elks No. 365. Here you can dine in comfort or lunch if you like. Well equipped dining room—liquor and beer served. Prices are right too and the service is the kind that satisfies. Give No. 365 a trial and you won't regret it.

**M**UCH TALK has gone by the boards on the glories of the Caribbean as a place to stay warm and toasty now that the ill winds are a-blowin'. Much has been written in this space and in others about the glories of say, Jamaica or Cuba, of the beguiling beat of the voodoo in Haiti, of the sandy beaches of the Virgin Islands, soft as baker's sugar, of the glitter of Puerto Rico and the calypso beat of Trinidad where verses and songs are manufactured to order on a moment's notice.

But what of the lesser islands? I mean lesser known. For in and about the West Indies are dozens of isles whose names are sounded less often, islands where the sun beats as strong and true, where the water and the sky are equally blue, and where, if anything, the landscape is blessed with fewer citizens, less neon, and infinitely more quiet and peace. Curacao is a shopper's paradise, a lodestone for cruise ships, but what about Bonaire? Barbados is very British and very cheap, but what about Antigua? Martinique is French and famous, but who has heard of Dominica? And Port

of Spain is filled with Indians from the Far East and color from the west, but what about Tobago? Not to mention Grenada, St. Lucia, St. Kitts and Saba. And even at that, the list is hardly half done.

Just twenty minutes by air from the comparative metropolis of Trinidad is the comparative seclusion of Tobago where the planes of British West Indian Airways land on a grass runway. Although a controversy still runs around literary circles, most quarters accept Tobago as the island which Defoe meant when he wrecked Robinson Crusoe on a desert island. (Tom Wrigley who writes our Washington column is apparently in disagreement on this point. In the September issue he speaks of Mas a Tierra in the Juan Fernandez group as the island described in Defoe's classic.)

For the tourist there are several handsome guest houses with far better accommodations than one might expect on an island of this size. About the most exciting thing you can do on Tobago is wait for the goat races or the horse races, each of which is held twice a year. There are excursions to see the rare birds that like the Tobago air and also the rare fish that enjoy the Tobago sea. You can put on a snorkel tube and sneakers and walk the bottom of shallow Buckoo Reef where the strange finny characters come in assorted shades and patterns of purple, gold and pink, and you can conceivably come away with the notion that you are on some weird, lost, underwater week-end.

Grenada, which lies to the north and west, is called the spice island of the west. It is British and it is beautiful. The hottest month is August and the rainiest times are July, September and October, all of which are out of the way when it is time for the winter visitor. Columbus discovered Grenada, the

## Elks Magazine Travel Service

Travel information is available to *Elks Magazine* readers. Just write to the Travel Department, *Elks Magazine*, 50 East 42nd St., N. Y., stating where you want to go and by what mode of travel. Please print name and address. Every effort will be made to provide the information you require, but kindly allow three weeks for us to gather the information. Because of seasonal changes in road conditions, if you are traveling by car be sure to state the date that you plan to start your trip.

More and more Elks and their families are taking advantage of this service. Are you?





French bought it with beads and brandy, and the English won it in 1763. Now you can get there on twice-a-week service via BWIA from Trinidad in fifty minutes. Grand Etang is a lake in a crater and there is a curvy road to reach it bordered with all the flora of the jungle. But most of all there is Grand Anse Beach which is a crescent of silver sand nearly two miles long, washed by clear blue water and devoid of signs, telephones, and popsicle salesmen.

French Line ships and Alcoa cruises and Canadian National steamers come to St. Lucia, a rugged mountain isle that is 27 miles long and 14 miles wide at its wider points. It has changed hands more times than a marathon bridge player, but at the moment it is British and probably will remain that way. Mountainous peaks rise straight out of the sea and Vigie Beach, ten minutes from the capital or a short boat ride across the harbor, is three and a half miles long. Pigeon Island Beach Club on Pigeon Island is reachable by launch and offers bar and bathing and dining in alfresco surroundings with a thatched roof to keep off the sun. It gets its name because the British Admiral Rodney kept a lookout on an island hill to watch the French fleet below and sent out the word with carrier pigeons.

They call St. Kitts the Mother Colony of the West Indies. Only 18 miles long and 5 miles wide, this little spit of land

is almost always caressed by a 79-degree temperature. Less than two hours south of Puerto Rico, St. Kitts is very British and has a Victorian look about it, enhanced by such names as the Pall Mall Gardens and the memories of Nelson who wooed the widow Nesbit on neighboring Nevis. The waterfront at Basseterre is really something to see and the boat will take you over to Nevis to see the birthplace of Alexander Hamilton and the sad ruins of many 18th Century plantations built by wealthy sugar and cotton planters.

Dominica sits between Martinique and Guadeloupe and on its twenty-mile long strip live the world's only remaining Caribs, the original Indians who inhabited the islands of the Caribbean when Columbus first hove into sight in 1492. Dominica has the highest peaks and the deepest dales, and in these valleys, so the local people say, are enough rivers for every day of the year. There is a new 16-room hotel, but the only way to make use of its two-year-old facilities is to book a seat on the amphibian plane which flies twice weekly from St. Vincent, Barbados and Martinique.

It is a good deal easier to get to Antigua, for Pan American flies in by way of Puerto Rico. And BWIA and Trans-Canada via Barbados provides service too. Alcoa, Canadian National and the Furness Line send their ships.  
(Continued on page 35)

Photo by Philip Gendreau



Visiting steamers anchor a few hundred yards from the streets of Roseau, capital of Dominica.

**NEW CARS—SELF DRIVE**  
BRITAIN and CONTINENT  
WINTER RATE EXAMPLE  
**4 PERSONS!**  
**1,000 MILES!**  
**\$70 14 DAYS!**  
34 (E35) INCLUDING Acre Lane 34 London, S.W.2 England  
GAS, OIL, INSURANCE Bri 4011  
**LESLIE WILSON GIVES SUCH PLEASANT SERVICE**





There's a place  
for YOU here—  
**BREMERTON ELKS LODGE**

Bremerton, Washington Elks Club offers travelers all the conveniences of a good hotel with the plus of a friendly, fraternal welcome. We have 18 rooms with bath—10 without. Stag bar, card room, billiards. Ample parking facilities and we are in a convenient downtown location. Breakfast and luncheon served and the food is good. Good times here too; dancing every Friday and Saturday nights and other social functions.

Your Brother Elks welcome you to

**LITCHFIELD, ILL., No. 654**

30 Rooms—with or without bath.  
Restful dining room and comfortable grill where finest food is served as you want it.\*  
Bar service—bowling alleys—television.  
\*Meals served members in clubroom also.



**FLORENCE SAYS "HOWDY"**

Florence, Colorado, B. P. O. Elks No. 611 offers traveling Elks and their ladies 21 excellent rooms and comfortable surroundings. No food served but convenient restaurant facilities available. Room rates \$2 per night. Liquors served. You'll find Florence lodge a fine stopping off place where a warm welcome awaits you.



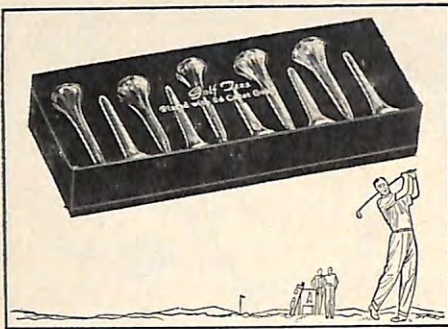

**GOLDEN GIFT FOR GOLFERS!**

Make this Christmas extra special... different and distinctive. Give a swanky set of **24-Karat Gold-Plated Golf Tees**. A truly beautiful Christmas gift for dub or pro! A **real money-saver for your gift list!** Only \$1.50 postpaid for set of 10. Comes in smart gift box—looks many times the price. Order direct by mail today!

**THE HOME SHOPPER**, Dept. E-12  
667 North Fairfax, Hollywood 36, California

**FLORIDA ZOMBIES!**

World's finest coconut confection. Saturated with a blend of rare old imported rum or tree ripened oranges. Packed in beautifully decorated one-pound tins.



*Ideal gift!*  
\$2.35 delivered  
to any point  
in U.S.A.

State flavor desired.

**ORDER NOW!**

**MEL LARSON'S FLAMINGO SHOP** LEESBURG, FLORIDA

**ELKS TIE BAR and CUFF LINKS**



**Ideal GIFT For HIM**

This beautiful matching set is plated in gold. The raised Elks heads are in 3 enameled colors, mounted on a mother of pearl plaque. **TIE BAR—\$5.00. CUFF LINKS—\$6.00. Combined SET—\$10.00.** Also available in Shrine, Kiwanis, Rotary & Lions. Prices include Air Mail return. Gift Packaged. Satisfaction guaranteed or money back. Order now.

**WALTER'S** 234 W. Valley Blvd. El Monte 26, Calif.



**SEE Better When You Drive!**

Amazing new **ALL-ANGLE** adjustable wing mirror instantly converts ordinary car mirror to **FULL REAR AND SIDE VISION!** Ends deadly "Blind Spots" forever. Nothing else like the new "Look Out" Mirror on the market. Gives you full, wide-angle vision with 180 adjustments on both wings. You drive **SAFELY** when you can see the road behind and all around. "Look Out" fits any mirror. No tools needed to attach. Durable, Triple-Chrome finish. Only \$2.50 post paid or C.O.D. plus postage. Play safe order today by mail. A wonderful gift.

**AMERICAN HOMECRAFT CO.**  
3708 Milwaukee Avenue, Dept. LM-2012, Chicago 41, Ill.

**ELKS FAMILY**



**A CHRISTMAS BELLE** will really turn heads when she wears this exclusive earring design, inspired by famous Swedish Angelabra. Little cherubs of gleaming lacquered brass spin, glide, pirouette with every move of a pretty head. All girls from 6 to 60 on your list will adore them. About 1½" long, gold screw-type backs. \$1.50 a pair, 2 prs. \$2.85 ppd. Red Oaks, Dept. E, Winnetka, Ill.



**30 LITTLE ANGELS.** The designers are really outdoing themselves on holiday trimming this year. These pint-sized cherubs, (1" tall) are among the cutest we've seen. Made in Italy, they're hand-painted plastic with smooth backs for pasting to packages, cards or even your teenager's party dress. Set of 30, assorted colors, \$1.00 ppd. Spencer Gifts, 7 Spencer Bldg., Atlantic City, N. J.

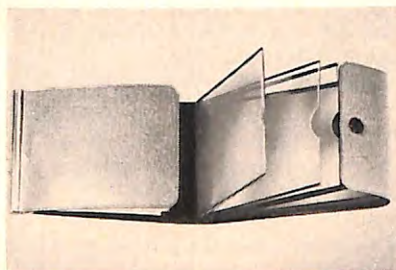

**PASS CASE** has 16 transparent sections for passes, cards, photos, plus special bill holder. Leather lined with snap fastener and easy-to-open bar for adding or replacing pass holders. Black or brown English Morocco, ginger or suntan Saddle Leather, natural Pigskin. \$2.75 ppd. incl. tax. Master Leather Crafters, Dept. E, 304 Cherry St., Philadelphia 6, Pa.

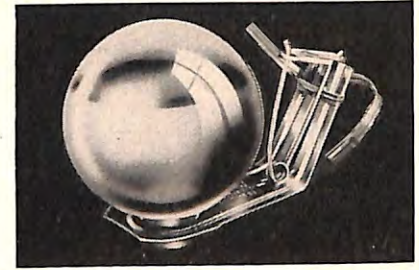

**FIREBALL** is a bright, gay Christmas tree fire extinguisher. You'd never know it from any other bauble but it'll snuff out a flash fire in seconds. Get one for trees up to 5' high; 2 or more for larger trees. Works on a thermal spring; gives year 'round protection in attics, closets, etc. \$2.95 ppd. Page & Biddle, 21 Station Road, Dept. E, Haverford, Pa.

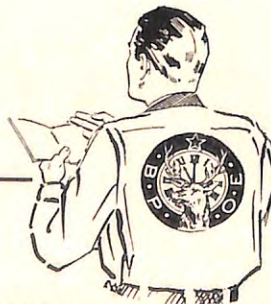

**MONOGRAMMED SHIRTS TAILORED FOR YOU!**

Beautifully tailored for perfect fit. Your name embroidered on pocket. Elk emblem on back in purple on white or white on purple. California styled. Tailored for freedom of action. Ideal for Drill Team, conventions, bowling, other sports.

**ORDER NOW FOR CHRISTMAS**

- SPUNRAY, white only . . . . . \$ 7.00
- LINEN, white or purple . . . . . 8.00
- GABARDINE, white or purple . . . . . 9.00
- SKINNER SATIN, white or purple . . . . . 10.00

Check or M.O. Mention Color, Collar and Sleeve Size  
FREE CATALOG ON REQUEST  
**BOWLERS SHIRT & UNIFORM CO.**  
116 W. Pico Blvd. Los Angeles 15, Calif.  
Suppliers of Elk Shirts & Regalia

**THE GIFT for a gardener**



**SOAKEZE** multiple plant soaker soaks roots in 5 flower beds at one time. Saves time and work. Attaches to any standard garden hose or faucet. Brass connection and 5 lengths of gleaming plastic hose (total 51 ft.) deliver water for deep, thorough soaking of selected plants. Light and durable. 5-year guarantee.

Gift-wrapped. We will enclose gift card and mail for you.

Same day shipment.



**JONS MFG. CO.** Dept. D-23, St. Matthews, S.C.



# SHOPPER



**SALA-TOSSA** provides a clever way to toss salads neatly, without spilling dressing or bruising greens. Remove top and it's a bowl to serve from. Stippled area inside is handy for rubbing garlic, onion, lemon. You need no separate grater. Both parts can act as servers for other foods. Translucent green polystyrene. \$2.95 ppd. Laurie & Co., 507 Fifth Av., Dept. EFS, New York, N. Y.

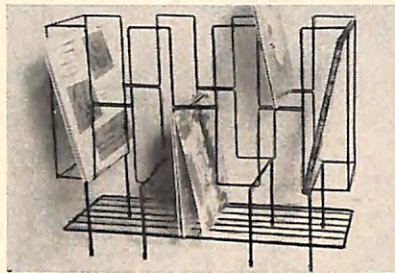

**WROUGHT IRON RECORD RACK** holds over 200 10" and 12" records without seeming cumbersome. It takes 78 RPM albums too. Black satin lacquer finish. 8 rubber tipped legs. Divided into 10 sections for storing music by composer, artist, label, etc. Overall size, 19 1/2" high, 25" long, 9 1/2" deep. \$9.95 exp. chgs. coll. Leslie Creations, 2116 Robbins St., Dept. 172, Philadelphia 49, Pa.

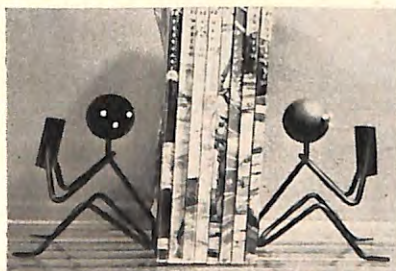

**HAPPY PAIR.** These whimsical Book Ends of wrought iron have round wooden heads you can turn so they assume comical tilts as they hold their open books. Shiny black with white bead features, 4 1/2" high. An imaginative gift for folks who don't like the run-of-the-mill. \$3.95 plus 25¢ postage. House of Bertram, P. O. Box 598-E, Scarsdale, N. Y.



**FOR SUNNY HOURS.** A handsome sundial straight from the gardens of yesteryear will add color and charm to your modern terrace or garden. Cast iron, 10 1/2" in diameter with polished cast brass arm. It bears a Browning poetical quotation on its verdigris face. \$6.95. In solid bronze. \$9.95 ppd. Bonney's, 121 East Broad St., Dept. E, Westfield 5, N. J.



**100 Toy Soldiers \$1.00**

**YES, 100 TOY SOLDIERS FOR \$1**

To introduce our line of molded plastic toys, we'll ship you 100 Toy Soldiers for only \$1. This big colorful assortment includes 4 Riflemen, 8 Machine-gunners, 8 Sharpshooters, 4 Infantrymen, 8 Officers, 8 Cannon, 4 Bazookamen, 4 Marksman, 4 Tanks, 4 Trucks, 4 Jeeps, 4 Battleships, 4 Cruisers, 4 Sailors, 8 WAVES, 8 WACS, 4 Bombers and 8 Jet Planes. Each toy is completely assembled, designed to scale, and measures up to 4 1/2". Order several sets NOW; your kiddies will love them. Send \$1.00 plus 25¢ for postage and handling for each set of 100 toys to:

**MODERN TOY CO., DEPT. EK**  
6614 Sunset Blvd., Hollywood 28, California



**PATAKWA MOCCASINS** — Ideal Gift from the Indian Reservation Country of soft, washable suede cowhide, with flexible padded soles. **BLISS TO WEAR** indoors or out with cuffs rolled up or down. **HANDCRAFTED** in Natural, Turquoise, Brown, Red, Emerald, Russet, Golden Corn, Indian White.

**FOR MEN AND WOMEN** in sizes 4 to 8. . . . . \$4.95  
in sizes 9 thru 12. . . . . \$5.95  
in natural or brown only.  
Sizes 5, 7, 9. . . \$2.95    Sizes 11, 13, 2. . . \$3.95  
Send cash, check or m.o. For COD's send \$2 deposit.  
Immediate delivery. *Satisf. guar. GIFT orders carefully handled.*

**OLD PUEBLO TRADERS**  
Box 4035, Dept. EP-1  
Tucson, Arizona

**Precious Miniatures from France**



**PARIS**

**Perfume Novelties—Genuine Limoges**  
delicately handpainted—14K gold trim

A. **Exquisite Egg** filled with heavenly, lasting solid perfume. . . . . \$4.75 ppd.  
B. **Petite Marmite**—little pot of solid perfume; cute as can be. *Beautifully packaged in cellophane, tied with silk ribbon inscribed "Souvenir de Paris."* . . . \$3.50 ppd.  
C. **Adorable Atomizer**. If she prefers to spray her favorite scent. About 3" high, a little beauty with wonderful Vapo bulb. . . . . \$4.95 ppd.

**TERRY ROBERTS**    116 E. 53RD ST.,  
NEW YORK 22, N. Y.

You will ENJOY pleasant, vigorous **VIBRATORY MASSAGE** with the Genuine **Battle Creek HEALTH® BUILDER**

"TOPS" for the Home, for Athletic Clubs, for Reducing Salons—for MEN and WOMEN!

Enjoy the relaxing, stimulating benefits of efficient vibratory massage! Health Builder gives you pleasant, scientific deep-tissue manipulation—"at the snap of a switch." Helps weight and figure problems, muscle-toning, blood circulation. Widely used in Health Institutions. Built for years of service—fully guaranteed. WRITE today for literature and new booklet, "BE GOOD TO YOURSELF!"

**Battle Creek EQUIPMENT CO.**  
BATTLE CREEK 11, MICH.

GET YOUR COPY

**MAKE YOUR HOME A SHOWPLACE THIS CHRISTMAS WITH...**

**SNOW-KIT**

Anyone can spray designs on windows, doors, etc. . . . or spray your tree!

**YOUR CHOICE**

1. lge. cn. white—lge. cn. red plus 7 stencils    **\$1.98** Ea. ppd. Sorry No C.O.D.'s  
2. lge. cn. white—lge. cn. blue plus 7 stencils

Easy to Apply . . . Easy to Remove  
**ORDER SEVERAL KITS TODAY**  
"SNOW"    Box 1422  
Detroit 31, Mich.

**THIS IS FOR THE BIRDS!**

Remember our feathered friends! Keep their lilting song in your garden. Here's a feeder that can be placed anywhere. 6 ft. steel post comes in 3 sections. Of brown steel with clear plastic hopper. Holds up to 2 lbs. Hood 14 3/4" across. Tray 9" x 3/4" deep. Ideal gift for bird lovers! Order by No. 0101A. Only \$5.98 ppd. Hanging model, same size (No. 0101B) \$3.50 ppd. Satisfaction guaranteed.

Write for free Gift Catalog

**DOWNS & CO., Dept. 3358, Evanston, Ill.**



# ORIGINAL Spruce ELECTRICAL MANICURIST

**For perfect manicures at home**

An ideal Christmas gift! Fast, gentle, safe... and so easy to use! In less than 10 minutes Spruce gives a beautiful manicure.

It shapes, buffs and cleans nails... whisks away excess cuticle... makes nails healthier, hands more beautiful. Erases corns and calluses from feet, too.

Ivory color, 4 1/2" high, 5 1/2" dia. Full set of attachments... shaper, buffer, cuticle lifter, cuticle brush, callus eraser. Operates on 110 V AC. Guaranteed to satisfy, or full refund. On market since 1938, many thousands in use.

Only \$24.95 complete, factory to you, postage paid anywhere in the world. Or send \$2.00, balance COD.

**ORDER NOW** or write for free descriptive literature.

**ABAR MFG. CO.**  
8720 Woodland Ave.,  
CLEVELAND 4, OHIO

- Nail Shaping
- Cuticle Lifting
- Cuticle Whisking
- Oil Massaging
- Callus Erasing
- Nail Buffing

**Fully Guaranteed**  
**\$24.95**

# Elks FAMILY SHOPPER



**MAGIC FARMYARD** has a simple, safe magnetic control that moves the farmer, his wife and the farm animals around the farm. Plenty of room for imagination in arranging figures. Animal sounds add to the real-life fun. 20"x11 1/4" playboard in glossy nature green. \$4.35 ppd. Selectoys, 34 W. 37th St., Dept. E, New York, N. Y.



**SPARKLING GUARD RINGS** set off a simple wedding band to perfection, are charming worn in sets of two or three. Choice of finely cut simulated rubies, emeralds, sapphires or imitation diamonds, hand set in sterling, \$3.50 ea. Matching bracelets hand set in rhodium, \$5.50 ea., ppd. Sanlys, Dept. E, 545 Fifth Av., New York 17, N. Y.



**DELUXE RELAXER** works wonders for that tired, aching feeling, actually relaxes your whole body by bringing your feet up. Stands without fastening to chair. Made of mahogany-finished plywood, padded with foam rubber and covered with leatherette. Folds flat for storage. \$5.98 plus 50c postage. Mastercraft, 212K Summer, Boston 10, Mass.



**REST AND REFRESHMENT** go together in this unusual Seat Cane with Flasks. Two 2 oz. plastic bottles are concealed in the aluminum shank. Press button, remove seat-handle, and there they are. Seat is finished with pliant, rubberized coating. Adjusts for height. A gay, sophisticated gift. \$9.95 ppd. Brey & Krause, Front & Chew Sts., Dept. E, Allentown, Pa.

**BASEBALL PICTORIAL '50**

**XMAS GIFT**  
FOR YOUNG AND OLD THAT'S ALSO PERFECT ALL YEAR-ROUND!  
SUITABLE AS A BIRTHDAY PRESENT!

100 pages, 8 1/2" x 11", with over 500 photos of every player in the Majors plus those in and returning from Armed Forces.

**ONLY \$1.50 EACH PPD.**

MAKES AN IDEAL ALBUM FOR **AUTOGRAPH COLLECTING**  
PLAYERS ENJOY SIGNING THEIR OWN PICS!

Sold by mail only—not available on newsstands. Send Cash. Check or Money Order—Sorry No COD'S.

**BASEBALL PICTORIAL**  
P.O. Box 1704 Dept. X Gd. Central Sta. New York 17, N. Y.

**12 Pc. IMPORTED SPORTSMAN'S COMBINATION KNIFE**

A COMPLETE CAMP KIT  
**Only 4.95**  
(A \$12.95 VALUE)

Labels: SCISSORS, KNIFE, SPOON, DRAW KNIFE, BONE HANDLE, FILE, CORK-SCREW, SAW & FISH SCALER, CAN & BOTTLE OPENER, AWL PUNCH, SCREWDRIVER, COVHIDE HOLSTER.

The Perfect Gift for Every Man and Boy!

Eliminates 12 Individual Items from your Pack or Tool Kit!

Complete with Genuine Leather Holster!

Here is the Perfect, Combination Knife-Tool for every Outdoor Sportsman. Hunter, Camper, Fisherman, Boy Scout, Rancher, etc. Think of it! It's 11. Fine quality Steel Tools, precision made to fold easily into the heavy bone covered body. In one neat, compact unit you have (1) a regular knife, (2) a fork, (3) a spoon, (4) a draw-knife, (5) a bone-saw and fish-scaler, (6) scissors, (7) a can and bottle opener, (8) a cork-screw, (9) awl punch, (10) a screwdriver and (11) a metal file. All this PLUS a genuine leather, belt holster.

ORDER NOW While We Can Guarantee Delivery at this Special Low Price

Order From This Ad. Pay by M.O. or check. P.O.'s except. from D&B firms. 1/2 deposit with C.O.D.'s. All Prices FOB Los Angeles.

**Palley SUPPLY CO.**  
2263 E. VERNON AVE., DEPT. E-12  
LOS ANGELES 58, CALIF.

**"HERE'S HOW!"**  
**CAP'N CAN OPENER**

It's for Tops! You can serve with a flourish when you open bottles or beer cans with this distinctive, sturdy Cap'n Can Opener. It comes in plain or carved Sterling silver that's perfect in detail... at home with any style of interior. You will take more pride in entertaining when your hospitality tray includes this Cap'n Can opener that combines usefulness with the lasting beauty of Sterling. A perfect gift for any occasion. Only \$4.95 Fed. tax included. Order now.

**AN ANTOINETTE GIFT**  
Dept. B201, P. O. Box No. 372, St. Louis 3, Mo.

**IT'S NEW!**  
**BOLT-N'-BUILD CONSTRUCTION TOY**

Kids, this is it! The very latest educational construction set that makes strong, sturdy, and mobile play toys that actually operate. Make your own wagon, steam shovel, autocar or scooter and many others from this unique set of blocks. Excellent play for children from 4 to 12 years. Each set consists of non-toxic colorful blocks in various lengths, a forged angle irons, large bolts and nuts and a forged wrench, packaged with instructions in sturdy storeaway carton. Master set \$16.95 plus postage. Junior Set \$9.95 plus postage.

Guarantee delivery on orders received before Dec. 15th

**QUALITY CREATIONS**  
72 Brookline Avenue, Albany 3, New York—Dept. E.

**Accordion Pak PHOTO & CARD HOLDER**

Designed for holding and displaying 16 photos and/or cards in one compact accordion-type folder. Accordion-Paks make ideal gifts. Made of tough, transparent vinyl which will not crack or discolor—in only \$1.00 each to 3 1/4" x 4 1/4".

Salesmen—Some territories still open. Dealers write for trade discounts.

**KIRK PLASTIC CO.** 168 E. Jefferson Blvd. Los Angeles 11, Calif.

**Cock and Hen Pheasants**

A man would like these Cock and Hen Pheasants in natural, bright colors. Cock 13 inches. Hen 11 1/2" long. Would go well on desk or T.V. Made of the famous North Dakota Clay. Set of two, \$9.75 Postpaid.

**HOFFMANN INDUSTRIES**  
Washburn, North Dakota



# Elks FAMILY SHOPPER

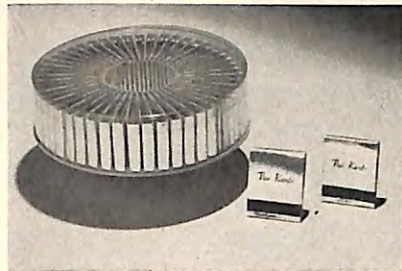

**MONOGRAMMED MATCH BOOKS** add a touch of luxury to your entertaining and make a most acceptable gift. Covers in silver, gold, red, green, dark blue, copper or white with contrasting monogram: (initials, two names or family name). Packed in acetate box. 50 books, \$2.25; 100, \$4.00 ppd. Monogram Shop, 84 Westminster St., Dept. E, Providence 3, R. I.



**SCRIBBLE DESK.** Young artists and writers will love to draw on this big yellow desk. A sponge wipes it clean, ready to use again. Comes with two sponges, four colored magic crayons, 12 inch ruler. Alphabet, Arabic and Roman numerals are painted along sides. Useful as lunch tray too. \$2.98 ppd. P. J. Hill, Dept. E, 101 Elizabeth Av., Newark, N. J.



**GIVE HER THE BIRD** and be loved for it. Feathered Brooch from Paris is the last word in smart accessories in that fashion-wise capital. Beautifully colored genuine feathers with head and feet of rhinestones in gold-plated mounting. Safety catch. Stunning on a suit lapel. Gift boxed. \$4.98 ppd. Terry Roberts, 116 E. 53rd St., Dept. E, New York, N. Y.



**JINGLE BELLS** for a ringing Christmas tree! That's right, hang them on the limbs as decoration and they'll tinkle merrily with every breath of air. They're tiny enough to tie on packages for a very special touch too. You get a big box of 75 metal bells in dozens of shapes and gay colors for \$1.00 ppd. Black & Co., 166 Merrick Rd., Dept. E, Rockville Centre, N. Y.



**SANTA AND 8 REINDEER!**  
Yours will be the "Christmas-iest" house in the neighborhood if you park Santa and his reindeer in front of it or on the roof! Arrange him and his reindeer along the living room wall for the most colorful, eye-filling indoor Christmas decoration imaginable. Weather-proof, heavy and colorful plastic. Sharp pointed prongs for inserting in soil or snow. Santa and sleigh measure 12" x 12". Reindeer and stake 13" high. **\$1.95** postpaid

**PERSONALIZED PILL TOTER**  
The perfect Christmas gift for the man or woman who carries vitamins, saccharin, etc. Two Cloisenee topped plastic vials fit into a fine top-grain leather case, initials in gold on red, green or brown leather. **\$1.95** postpaid

**PERSONALIZED "CRY BABY" BALL**  
Roll it along the floor; when it stops, it cries "Mama"! Baby will never tire playing with it—and it has first name on it, hand-painted—with special, non-chipping, non-toxic washable paint. Pink, blue; sturdy plastic. **\$1.50** postpaid

**HAND-PAINTED CHINA BELLS**  
New and different tree decorations that really "ring the bell"! Use them also as delightful package tie-ons or group them on the mantel. Beautiful hand-painted decorations on fine china—there are 12 to the set, each one different. They really ring. 1 1/2" high. Set of 12—**\$1.50** postpaid

Write for Free Christmas Catalog.  
**BLACK & COMPANY, INC.**  
117 Black Building, Rockville Centre, N. Y.

**YOUR Personal PRINTER**  
**\$1** VALUE  
**75¢** Postpaid

**Personalized • Pocket Size • Perfect Gift**  
Prints name and address, plainly. So handy for home or office. Looks like printing, saves cost of printing. For envelopes, stationery, calling cards, checks, books, records, etc. Fits pocket or purse. Complete with hinged black plastic case and built-in ink pad. A \$1 value! Send only 75¢ with name and address (3 lines, 25 spaces each), 6 for \$1. Satisfaction guaranteed.

**FISHER'S** 1110 E. 47th Place, Dept. PE12  
Los Angeles 11, California

**LOOK BETTER! FEEL BETTER!**

**USE A Vibrosage®**  
**ELECTRIC MASSAGER**  
\*Professional-Type  
\*4 Scientifically Designed Applicators  
\*Sanitary  
A few minutes daily use of VIBROSAGE gives that stimulating, helpful aid to circulation... relief from aches and pains. Four applicators assure maximum effectiveness for scalp, face and body. Operates on 110 volt, 60 cycle A.C. **Five day trial—money-back guarantee!** Send \$8.95 check or money order, for prepaid shipment. Or, send \$2; pay postman balance plus postage and C.O.D. charges.  
**BEAUTY APPLIANCE CORP., Dept. V934-M, Racine, Wis.**

**A Beautiful Distinctive Gift**  
**LUHR'S SPIN PACK #101**  
Pocket size, waterproof plastic case with 12 world famous Luhr Jensen spinning lures. Felt lined with foam rubber cushion in lid to hold lures in place—steel hinges. Ideal for carrying 3-pronged hook lures—beautiful, practical and durable.  
**Complete \$9.95**  
At dealers or send check or money order direct. Immediate delivery  
**LUHR JENSEN & SONS**  
Hood River 3, Oregon

**SHOE SHINE KIT**  
E-Z Shine Holders are made of strong aluminum. Detach from wall bracket. 3 changeable toe plates for men, women and children (for all size shoes). Chrome-like finish. Guaranteed. C.O.D.'s pay postage. Look sharp at low cost. **FREE** chemically treated shining cloth with each kit.  
A useful gift for all occasions  
**WAYNE Mfg. Co.**  
**\$2.95**  
Dept. E-35, WAYNE, PA.

**THE PERFECT GIFT or TROPHY**  
**This World Famous (Tie Clip) SPINNER**  
(Inlaid with gold and silver by hand—involving a 400 year old art.)  
The clock dial and B-P-O-E are on one side of the disc, on the other, the Elk's head and star. Spin the disc, and you will see them as one emblem. A practical and serviceable item anyone would be proud to wear. It is amazing the psychological interest that is created by this illusion. The greatest animating novelty ever made for lodge emblems. Also available for all Masonic bodies and other orders. Quantity discount to secretaries. All orders will be filled immediately.  
**RAY VAUGHN & CO., NOVELTY IMPORTERS**  
5454 Aura Ave., Tarzana, Calif.

**JACK-POT DICE**  
**NEW EXCITING GAME**  
Slot machine fascination and dice excitement for any number of players. Set includes 3 white Catalin plastic dice with each symbol in bright colors. Durable plastic shaker. Award chart & rules. Gift packed. An intriguing game for adults. Only **\$2.00**, PP.  
Free catalogue. No C. O. D.'s. Dealers Wanted.  
**LUDERUS BROS.** Dept. 5  
4734 No. 34th St. Milwaukee 16, Wis.





THE Most Delicious GIFT!  
**FORST** CATSKILL MOUNTAIN  
**Smoked TURKEY**

Here indeed is a delicacy fit for a king's own feasting, a magnificent Forst Catskill Mountain Smoked Turkey. A never-to-be-forgotten treat to the palate—the smoke-sweet flavor of each turkey is indescribably delicious. We start with extra-plump birds, cure them in rare, zesty spices and aromatic herbs, then slowly smoke them over fragrant applewood embers, according to a secret Forst family recipe. Whole smoked turkeys range from 8 to 20 lbs. (net smoked weight.) All ready to slice and serve. Price of \$1.70 per lb. includes delivery charges, beautiful, festive gift wrapping. Order today, solve all your Christmas gift problems the easy, delightful Forst way!

Yours FREE! The magnificent new Forst catalog . . . bursting with holiday entertaining tips, and roster of Forst delicacies. Send for your copy today.  
**THE FORSTS**, Route 333, Kingston, N. Y.  
 All Forst Products are Government Inspected

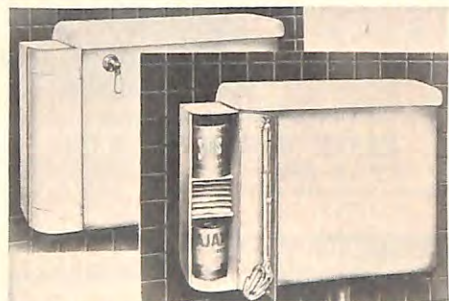

**Out-Of-Way De luxe metal cabinet** for the bathroom has 3 shelves to hold soap, tissues, etc. Comes with Jonny Mop Handle which hooks on door, and 6 pads in special compartment. Baked white enamel finish. Clips to either side of tank, takes only 4 1/2" space. Gift idea. \$3.98 ppd. Northern Industries, Inc., Dept. E, 407 E. Michigan St., Milwaukee 2, Wis.



**AMAZING VALUE**  
 in 100% CLEAR HAVANA!

Only imported A-1 tobaccos are used in LA ROVEGA. Made in one of America's most respected Government BONDED factories. U. S. Customs seal on every box. Here's a truly mild tasty smoke . . . with all the delicious flavor and aroma that only fine clear Havanas can give you. Compare with any famous make 15¢ or 3/50 clear Havana, you'll be amazed at the great savings you can now enjoy . . . full length LA ROVEGA Princess.

ONLY \$885 per 100 Postpaid



**100% CLEAR HAVANA IMPORTS!**  
 FROM CUBA TO YOU FOR LESS!

Enjoy flavorful, tantalizing GISPERS. . . Choice of Cigar Connoisseurs in 38 countries . . . Only most expensive Longfiller, 6 yr. tobaccos used . . . The most perfect hand-rolled cigars . . . Seal of Cuba Guarantee on every box . . . Order several sample boxes at this low introductory price.

ONLY \$4.60 per box Postpaid

**HAVANA-FLORIDA CIGAR CO.**  
 DEPT. 76, 631 Newark Ave., Jersey City, N. J.

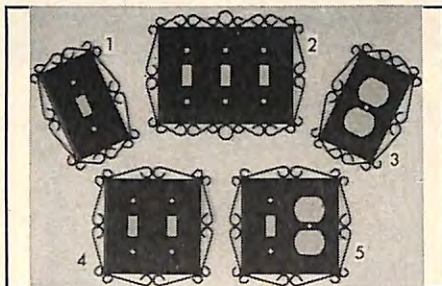

**NEW WROUGHT IRON SWITCH PLATES**

Attractive, electric switch ornaments of sturdy black metal designed to add warmth and beauty to the walls of any style home . . . from Provincial to Modern. These rich looking wrought iron scalloped framed plates fit over any wall switch or outlet. Ideal for any room . . . living room, kitchen, bedroom, den, foyer, etc.  
 (#1) Single switch \$1.35 ea. (#2) Triple switch \$1.95 ea.  
 (#3) Duplex outlet \$1.35 ea. (#4) Double switch \$1.65 ea.  
 (#5) Combination switch & outlet \$1.95 ea.  
 (No C.O.D.'s please.) We pay postage. Money refunded if not delighted. **ORDER NOW!**  
**Laurie & Co., Dept. EL, 507 5th Ave., New York 17, N.Y.**

**A PUTTING CUP**

to meet actual putting requirements. Cup opening is actual size. Use with a regulation golf ball and putter. Instructions and markers for playing 9, 18 and 36 hole tournaments in your own home. Improve your golf by mastering putting. \$3.50 ppd.



**GOLF PERFECTING CUP**  
 209-10th Street, Bismarck, North Dakota

**A Place in the Car**  
 For Your Favorite Pipe

Pipe-Rak holds pipe firmly upright. **NO MESS. NO SPILLING.** Adjusts for bowl size and drying angle. Vacuum cup attaches it to any smooth surface. Suede finish inside protects pipe. Exposed metal 14K gold plated. \$4.95. Chrome, \$3.95. Three initials engraved \$1. Standard model (all suede, not personalized) \$2. Satisfaction guaranteed. No C.O.D.'s please.



**BOYD F. SCHERNBECK**  
 5713-E Standish Ave. Minneapolis, Minn.

**A SUPERB GIFT EVERY ELK WILL TREASURE**



This year give him a distinguished personal gift that will be a lifetime remembrance and that he will proudly wear. The new Elk membership pin, approved by the Grand Lodge, is 10k gold, with gold plated post and attaching button. \$7.35, including shipping. Delivery within two weeks from receipt of order. Purchases for delivery in N.Y.C. add 3% to price. Send order to Department M, **THE ELKS MAGAZINE**, 50 East 42nd Street, New York 17, N.Y.

**Elks FAMILY**



**KNEE-LIFT CUSHION** permits that slight flexing of the knees when lying on one's back that relaxes the whole body. This knee support is what makes contour chairs so comfortable. Recommended in books on relaxing, it's especially good for older folks and invalids. \$3.50 ppd. Better Sleep Co., Dept. EM, New Providence, N. J.



**NINA BALLERINA** actually dances on her toes. A real performer, she takes short dancing steps when you hold her hand, turns her head from side to side, does splits and can stand alone! Her Saran hair is rooted into her head, can be shampooed, combed and set. Dressed in an authentic ballet costume of glittering lame, net and sequins, she stand 20" tall on her toes. \$9.95 ppd. Niresk Industries, Dept. NB-15, 4757 Ravenswood Ave., Chicago 40, Illinois.



This fabulous brightly colored silk screen processed "SANTA" on paper 25 x 21 inches . . . 4 for \$1.  
 "SANTA'S" head only, in paper . . . 12 for \$1.  
 The same gorgeous "SANTA" done in brilliant flaming red and white, silk screen, on 14 ply cardboard, with easel and including "MERRY CHRISTMAS" . . . \$1.50

"SANTA" for outside decorations, cut from specially treated white pine, done in glittering waterproof colors, including "MERRY CHRISTMAS" in SCOTCH-LITE that reflects the light so vividly it actually seems to be NEON lighted, complete post paid . . . \$9.95

Be sure to print your order, name and address plainly to eliminate mistakes. Place your ORDER EARLY and enclose the correct amount to insure prompt delivery.  
**C & O NOVELTY CO., 16 Cannon St., Pittsburgh 5, Pa.**

**FORCES You to Save \$100.00 a Year Automatically!**

Get perpetual Date & Amount Bank. 25c a day keeps Calendar up-to-date. Also registers amount saved.



Forces you to save a quarter every day, or date won't change. Use year after year. Start saving right away. Order several. Reg. \$3.50—Now only \$1.99 postpaid. Mail cash, check or money order to **LEECRAFT**, Dept. EL, 300 Albany Ave., Brooklyn 13, N. Y.



# SHOPPER

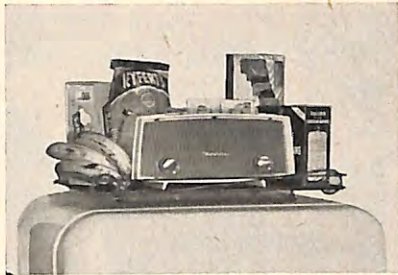

**STORAGE SPACE** atop your refrigerator can be put to use attractively with the Refrigerator Caddy. Wrought iron, with suction cup feet, it converts curved top to flat surface for holding radio, bananas, cook books, whatever you wish. 22" x 16". \$3.00, plus 35¢ West. Vermont Crossroads Store, Dept. E, Waterbury, Vt.



**A CHEST TO TREASURE** is this little gem of Italian handiwork. The inlaid cover is made of tiny, handcarved varicolored pieces of wood. Divided compartment holds cards, cigarettes, trinkets. Below is a pull-out drawer. 6½" long, 4½" wide. \$3.95 ppd. Artcraft, 1133 Broadway, New York, N.Y.



### MOTHER-IN-LAW EARRINGS

Legend has it, were to warn a good Navajo Indian of her approach, so he could clear out (as was the rule). Now they're top fashion for all. Sterling Silver . . . \$1.95, Sterling with turquoise blue stones . . . \$2.95 (screw or pierced)

Order by mail today. No COD's. Send cash, check or m.o.  
**OLD PUEBLO TRADERS,** Box 435, Dept. LL, Tucson, Arizona

### MY GRAY HAIR IS NATURAL LOOKING AGAIN says JAN GARBER,

Idol of the Airlines

"No matter what color your hair was (black, red, brown, blonde) before it turned gray. TOP SECRET gives gray hair youthful, natural looking color!" says Jan Garber, famous dance band leader. "I noticed results after just a few applications. And TOP SECRET is easy to use—doesn't stain the hands or scalp. I look years younger. TOP SECRET is the only hair dressing I use."



### YOU LOOK YEARS YOUNGER

TOP SECRET has been a favorite with famous personalities for years. Exclusive formula imparts natural looking color to gray or faded hair. Does not streak or injure hair. NOT A TENT. \$5.00 (Fed. Tax incl.) for 6 oz. bottle, ppd. No COD's, please. Money back if you're not delighted with results. Albin of California, Room 4M 1401-97 W. 8th St., Los Angeles 17, Calif.



### NEW Accurate Attractive BAROMETER

Know the weather at all times with this fine Barometer. Works automatically. Foresees rain, fair weather or even hurricanes. Ideal for placement on desk or mantle. Handsome brass case and stand, rich looking dial. 3½" x 3½". Just \$5.95. Not shown, a matching Thermometer and Humidity Indicator, \$4.95. The two together make a delightful set for home or Christmas gift. Only \$9.95 for set. No C.O.D.'s. Money Back Guarantee.  
**TALNER, Dept. E-1, 565 Main St., New Rochelle, N. Y.**



### FAY'S SMOK-CLIP The Ideal Gift

For all sportsmen. Holds lighted cigarette securely. Leaves both hands free. Clips anywhere—in pocket, golf bag, cap, anywhere. Highly polished stainless steel . . . individually boxed, mail \$1.00 TODAY. Prepaid.

**FAY PRODUCTS** 4133 Irving Street, San Francisco 22



This year give him the new Moto-Kaddy—combination motor stand and carrier, developed to haul and store motors from 5 to 50 H.P. without body strain. Only \$10.95. Exp. chgs. coll. Order early. No C.O.D.'s Please.

### HALLIDA SALES

P. O. Box 662 Canton 1, Ohio

### BRINGS LOST DOGS HOME

\$1.50 Postpaid

### PERSONALIZED PET TAG

brings straying pets home. Chrome plated brass. Lasts a lifetime. Also excellent for umbrellas, luggage, golf bags, etc. Print full information when ordering. (LIMIT—6 lines of copy). We reserve the right to abbreviate or substitute larger tag if necessary. Order direct from this ad or Write for our Catalog.

**SPENCER INDUSTRIES** 1508 N. Mascher St. Phila. 22, Pa.



### New CAR EMBLEM

• ATTACH TO LICENSE PLATE  
 OFFICIAL COLORS LASTS FOR YEARS



The B.P.O.E. emblem is your introduction on the road wherever you go. Attractive red, blue and gold design. Mounted on non-corrosive frame. Easily attached. Send \$1.49 or 2 for \$2.50 (we pay postage) or C.O.D. (you pay postage). Money-back guarantee.

**STA-DRI PRODUCTS CO.** 147-47C 6th Ave., Whitestone, L. I., N. Y.

"MERRY CHRISTMAS" TALKING SANTA 3¼x4½" colorfully printed plastic. When loop at the top of the head is tacked to door or held in left hand, the right thumb nail drawn down the tape extending from the mouth Santa says "MERRY CHRISTMAS"



4 for \$1.00 No COD's

**BORKLAND MANUFACTURING CO.** MARION, INDIANA  
 Quantity prices to clubs

**ITALIAN ACCORDIONS special DISCOUNT TO MEMBERS OF THE ELKS** 5-DAY FREE TRIAL

"PAY AS YOU PLAY" Small Down Payment As Little As \$10 per month

DIRECT from Importer to You!

SATISFACTION GUARANTEED, or your money back! NOW you can save up to 50% by direct purchase from America's leading distributor of famous genuine ITALIAN ACCORDIONS. TRADE-INS ACCEPTED. MAIL COUPON TODAY—World's Largest Selection

PLEASE RUSH FREE COLOR CATALOG

Name \_\_\_\_\_  
 Address \_\_\_\_\_  
 City \_\_\_\_\_ Zone \_\_\_\_\_ State \_\_\_\_\_

**ACCORDION MANUFACTURERS & WHOLESALE OUTLET**  
 2003 West Chicago Ave. Dept. K-124, Chicago 22, Ill.



**SCULPTURED ROSES in STERLING SILVER**  
 by Dancraft • A Gift She'll Cherish and Treasure  
 Exquisitely wrought with deftly hand-turned rose petals. Naturally lovely with a vibrant beauty.

- Necklace (16" to 18", adjustable) . . . . . \$13.20
- Bracelet (choice of 8" or 7¼") . . . . . 9.35
- Earrings (screwbacks or pierced) . . . . . 4.95

Complete Set \$26.00

Prices include 10% Fed. tax, postage and handsome Gift Box. Add 25¢ for Air Mail. Money Back Guarantee  
**ALPINE IMPORTS** Dept. EL-5 505 Fifth Avenue New York, N. Y.



### MAGIC-RACE

Just touch the star on this specially treated paper with a lighted cigarette and the race is on! Slowly the ember creeps across the sheet in six separated lines, and the first to reach the finish is the winner. A different winner on each sheet, 55 races to package. Exciting, fun and safe, too!

\$1.00 ppd.

**Serv-U** Write for FREE catalog  
 P. O. Box 390E, Flushing, New York



**SOLVE YOUR GIFT PROBLEM  
CHRISTMAS CANDY**

Delicious, unique mint  
assortment mailed anywhere!



Gift package #1—2 lbs. Wilson assortment (1/2 lb. each): Delicious Swedish Mints, Butter Mints, Rum Butters & Pastels. \$2.50 postpaid, in reusable containers.



Gift Package #2—Same contents as #1, \$2.50. Money back guarantee. Must order by Dec. 10 for Christmas delivery. Send us your gift list (for business, friends or family) & name for gift card enclosure.

Send for price list of quantity candy for Christmas parties, etc.

**CANDY PACK, INC.,** 5638 N. Western, Chicago 45

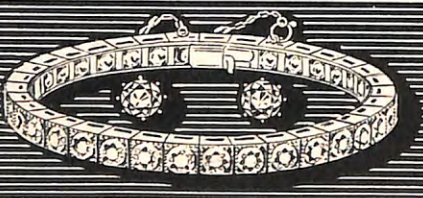

**Like Matchless Diamonds in all but Price!  
Genuine ZIRCON Flexible Bracelet**

This Christmas you can give lasting luxury at a low price. 44 sparkling, fiery-white genuine zircons, hand set in sterling silver. An exact replica of a costly diamond and platinum bracelet, it is brilliant as diamonds themselves. An exceptional value at \$75, *not unbeatable* at

Only \$49.50  
tax included

**Zircon Solitaire Earrings**

Weighing 3 1/2 carats—set in 14K white or yellow gold. For pierced or unperfed ears. Regularly \$45

Only \$24.95  
tax included

**SANLYS** 545 Fifth Avenue, Dept. E-12, New York 17, N. Y.

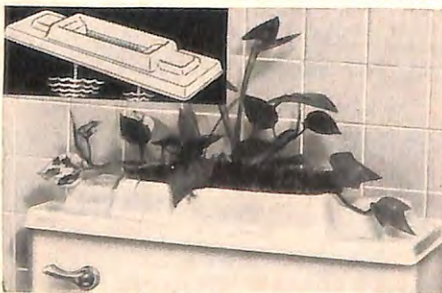

**JONNY PLANTER** for your Bathroom  
New ideal Self-watering decorative planter for top of toilet fixture. White molded lid with deep planting area made to fit any standard toilet fixture, replacing the porcelain lid. Special absorbent wick hangs in water of tank, and across bottom of planter to constantly and automatically water plants. Complete with adapter to fit any tank. A really new idea in modern decorating. \$4.95 ppd. No COD's. Carol Beatty, Dept. Z12-W, 7410 Santa Monica Blvd., Los Angeles 46, California. Send for FREE GIFT CATALOG of 300 selections.

It's a "summer vacation"  
all winter  
when you  
**TREAT the FAMILY**  
to Genuine  
Battle Creek **BISOLAR**  
"SUNSHINE"



Like a healthful, sun-tanned appearance all year 'round? Here's wonderful protection for you—and all the family—with scientifically balanced artificial sunlight that contains both ultraviolet and infrared rays. "At the snap of a switch" the NEW BISOLAR Lamp delivers "made-to-order" light that tans faster than the sun. If you relax and fall asleep, automatic "Soltimer" turns lamp off at the preset minute—fully protects against overexposure! Pedestal, wall and ceiling models. Money-back guarantee. Write at once for free literature!

**Battle Creek** EQUIPMENT COMPANY  
BATTLE CREEK 13, MICHIGAN

A Gift For Your Scouting Son  
For Christmas or Birthday

**HARVILL**

**LITE**  
and  
**COOL**  
PACK RACK . .

Light, cool, fits all standard packs. Slips off quickly, adjustable. Frame of light metal alloys, holds weight comfortably, air circulates between pack and back. Ideal for hiking, skiing, hunting, scouting and riding. See your favorite sporting goods dealer or order direct. \$6.85 ppd.

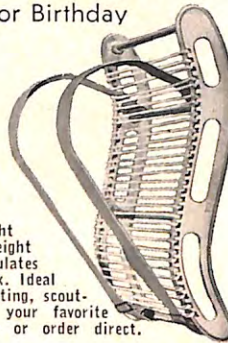

He'll Want A Lite Bag, Too. . .  
17" x 14" x 5" \$5.45 ppd.  
17" x 14" x 8" \$7.85 ppd.

**H. L. HARVILL MFG. CO.**  
Dept. E-12, Corona, California



**NOW! The Quietest  
Ride of Your Life!**

These amazing new "Wind Silencers" work like magic to reduce wind-roar and noise to a quiet whisper. Listen to your radio—talk in a normal tone of voice no matter how fast you drive. No more brain-fog or frazzled nerves. They're gone forever when you install "Wind Silencers." Designed by an aeronautical engineer. Made of stainless steel. Easy to install. Two units—one for each front window—now only \$2.98 a pair. Order today by mail—send check or money order and we pay postage. A wonderful gift.

**AMERICAN HOMECRAFT CO.**  
3708 Milwaukee Ave., Dept. WS-2012, Chicago 41, Ill.

**Elks FAMILY**



**SATIN PILLOW CASES**, the acme of luscious luxury. Of finest quality all-satin with embroidered hems, they wear for years, launder beautifully. In white, pink, blue, ivory, yellow, green, gold, crimson or black. Standard size, \$7.95 per pair ppd. Also satin zipped pillow protectors, same colors, 21" x 38", \$3.25 ea., 21" x 36", \$3.50 ea. Ruth Brawer, Box 4035, Dept. ELX, Tucson, Arizona.



**NO GAG**—he's a real Jerry Mahoney, the talking imp of TV fame. You just put the words in his mouth and he'll be the life of any party. 24" tall, with movable head and mouth, snappily toggled out in a two-toned flannel and gabardine suit. With instructions, \$6.98 ppd. Lowy's, 260E 116th St., Rockaway Park, N. Y.

**This Christmas Give Yourself—Your  
Friends This Blessed Gift of SLEEP**



Everybody loves this new **BLANKET SUPPORT** because it frees their feet from blanket weight. NOW they sleep quietly relaxed and awake refreshed. The difference is truly amazing! Ingenious folding arms make a cozy, restful foot pocket indispensable to uncomfortable sleepers. Relaxes tensions that cause insomnia and irritations. Improves circulation, eases rheumatism and foot cramps. Increases electric blanket comfort. Enjoyed by arthritics and the aged. Fits any bed. Arms fold down flat when bed is made. Praised by thousands of restless sleepers, doctors and hospitals. Tested and approved by "Foot Health Committee, N.Y.C." A Christmas gift guaranteed to please, or your money back. Only \$4.75. (Extra-fast mail, \$4.98.)

**BETTER SLEEP CO., Dept. 155**  
NEW PROVIDENCE NEW JERSEY



# SHOPPER

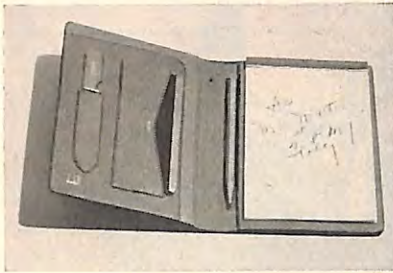

**PIGSKIN POCKET SECRETARY** is a rich-looking, useful gift any man will treasure. Natural, genuine pigskin with handrolled edges, it comes with memo pad, magnetic pencil, comb and nail file in golden jeweler's bronze. Three gold initials embossed free. \$10.95 ppd. inc. tax. Talner, Dept. EL, 565 Main St., New Rochelle, N. Y.



**PERSONALIZED NAME TAG** "License" for Junior's rolling stock. Be it baby buggy, crib, tricycle, bicycle, scooter or wagon, it's young occupant will be all the prouder for this mark of ownership. Send child's name (up to 7 spaces). \$1.00 ppd. B. Cantor, Dept. E, 1711 Walnut St., Phila., Pa.



**STILL TIME TO SAVE UP TO \$42**  
ON WORLD FAMOUS 15 AND 17-JEWEL WATCHES

## BULOVAS

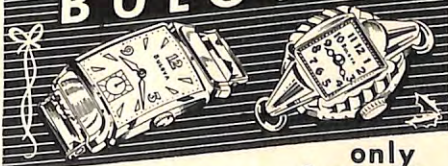

Send only \$1 — balance plus postage C.O.D. Wide assortment thrilling latest-style 14k gold-filled BULOVAS — two illustrated above. Bankrupt and surplus stocks and unredeemed watches, fully reconditioned. Also Gruen, Elgin, Waltham, Benrus and other leading brands. Lifetime written service GUARANTEE. Use 10 days; money back if not satisfied. Remit in full and WE pay postage. FREE handsome expansion band with orders received this month!

Write for FREE catalog of diamonds, pearls, watches, costume jewelry.

**SPECIAL Water-Rust Resistant, Shock-Protected INCABLOC. Sweep-second-hand, Luminous Dial, Swiss Precision Movement. Lifetime Service GUARANTEE.**

**\$14.95 PLUS \$1.50 TAX**  
LADIES' STYLE \$16.95 plus \$1.70 tax.

**TRANS-WORLD DISTRIBUTING COMPANY**

Suite 1616 A - I.C.T. Bldg., Dallas, Texas



## SUSIE WALKER WALK HER DOLL

With Long, Silky, Washable SARAN Hair

- SUSIE DOES EVERYTHING**
- She Walks—Sits—Stands
  - Turns Head As She Walks
  - She Cries—She Sleeps
  - "Magic Action" Legs
  - Completely Washable
  - Unbreakable Construction
  - Guaranteed Walking Mechanism
  - BIG 20" TALL

So Lifelike you'll think she's a real girl walking with her little mother. Susie Walker is beautifully formed, even to the small details of finger nails, dimples and creases in her chubby arms and legs. She assumes and will hold (no flopping) all lifelike positions. Susie can be washed, dressed and undressed in standard 20" doll costumes. Her hair can be washed and combed; her pigtails braided and set in any fashion desired. Nothing can go wrong with her working parts and she is molded of the new shockproof plastic that assures years and years of loving play. Susie Walker is the answer to every girl's prayers. Commended by Parents Magazine. Union-Made in U.S.A. by skilled American workers. Satisfaction Unconditionally Guaranteed!

**SUSIE WALKER IS ALSO AVAILABLE IN THE LARGEST SIZE MADE—23" TALL. Nationally advertised at \$15.95. OUR PRICE—\$5.95 plus 50c shipping or C.O.D. plus postage.**

**SMALLER SIZE SUSIE WALKER: All above features but No Voice—14" TALL. Reg. \$5.95. OUR PRICE \$2.98 plus 50c shipping or C.O.D. plus postage.**

**Nationally Advertised At \$9.95**  
SENSATIONAL VALUE — ONLY **3.98** dressed plus 50c shipping or C.O.D. plus postage

**NOW YOU CAN DRESS SUSIE, TOO—SAVE MORE THAN 50% ON HER CLOTHING.**

Style	14" Size	20" Size	23" Size
Hat & Coat Ensemble	79¢	98¢	\$1.10
Bridal Ensemble	98¢	\$1.49	\$1.79
Plaid Vinyl Raincape	29¢	39¢	49¢
Ballerina Outfit	49¢	98¢	\$1.10
Hostess Coat	29¢	69¢	79¢
Sheer Nightgown	39¢	59¢	69¢
<b>SPECIAL PRICE IF YOU ORDER ALL SIX OUTFITS</b>	<b>\$2.98</b>	<b>\$3.98</b>	<b>\$4.98</b>



**P. J. HILL CO. Dept. P-732 933 Broad Street, Newark, N. J.**



Give the Utmost in Smoking Luxury!  
**TWO MATCHED-GRAIN EHRlich PIPES INDIVIDUALLY MONOGRAMMED**  
At a Special **\$7.50** Set  
Christmas Price Postpaid

Give the FINEST... Give EHRlich Pipes, the recognized Hallmark of Quality in Pipe Smoking Enjoyment since 1868! NOW... offered to Elks Magazine readers... 2 matched-grain, rare, old, seasoned Algerian briar pipes in popular shapes, styled and hand-finished by master craftsmen in EHRlich's famous Boston shop; personally monogrammed, and fitted in plush-lined, silver-embossed maroon jewel case... at the unheard-of low price of just \$7.50!

ORDER NOW for prompt delivery! PRINT Monogram Initials desired... Send Check or Money Order NOW to

**DAVID P. EHRlich CO.**  
Dept. G, 207 Washington Street, Boston 8, Mass.

## SINGLE ACTION FRONTIER SIXSHOOTER

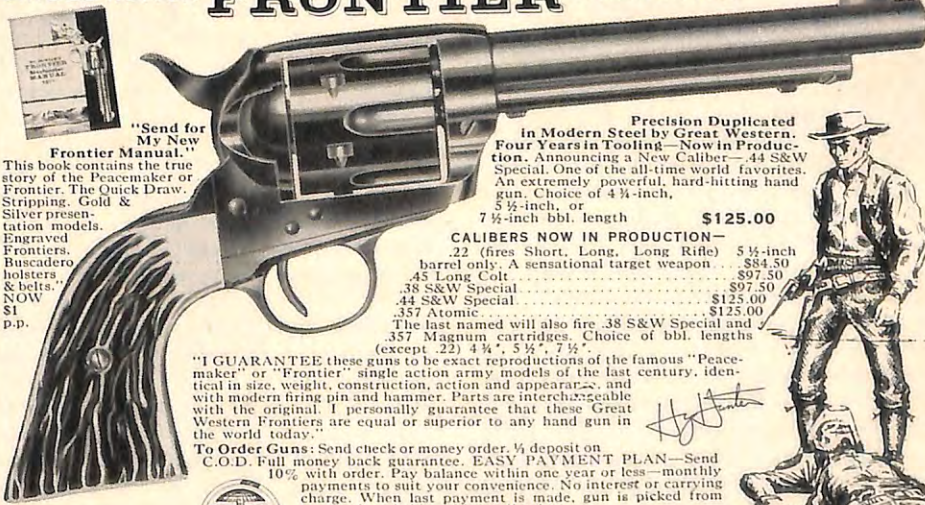

"Send for My New Frontier Manual." This book contains the true story of the Peacemaker or Frontier. The Quick Draw. Stripping. Gold & Silver presentation models. Engraved Frontiers. Buscadero holsters & belts. NOW \$1 p.p.

Precision Duplicated in Modern Steel by Great Western. Four Years in Tooling—Now in Production. Announcing a New Caliber—44 S&W Special. One of the all-time world favorites. An extremely powerful, hard-hitting hand gun. Choice of 4 1/4-inch, 5 1/2-inch, or 7 1/2-inch bbl. length **\$125.00**

- CALIBERS NOW IN PRODUCTION—**
- .22 (fires Short, Long, Long Rifle) 5 1/2-inch barrel only. A sensational target weapon... \$84.50
  - .38 S&W Special... \$97.50
  - .44 S&W Special... \$125.00
  - .357 Atomic... \$125.00
- The last named will also fire .38 S&W Special and .357 Magnum cartridges. Choice of bbl. lengths (except .22) 4 1/4", 5 1/2", 7 1/2".



"I GUARANTEE these guns to be exact reproductions of the famous 'Peacemaker' or 'Frontier' single action army models of the last century, identical in size, weight, construction, action and appearance, and with modern firing pin and hammer. Parts are interchangeable with the original. I personally guarantee that these Great Western Frontiers are equal or superior to any hand gun in the world today."

To Order Guns: Send check or money order, 1/4 deposit on C.O.D. Full money back guarantee. EASY PAYMENT PLAN—Send 10% with order. Pay balance within one year or less—monthly payments to suit your convenience. No interest or carrying charge. When last payment is made, gun is picked from our stock and shipped immediately.



**HY HUNTER**  
3029 WEST BURBANK BLVD., BURBANK 64, CALIF.





# In the Doghouse

**At Christmas time, one of the nicest things for a child is a puppy.**

**with Ed Faust**



**A**LONG about this time of the year a stout elderly man with a bulbous red nose and a benign countenance makes brief appearances in our village. He has been doing this for more years than our oldest resident can recall. For some reason he is a great favorite with young children and some few trustful grown-ups. Now where I live, idleness is not encouraged and I am told that many years ago this character was picked up for vagrancy as he had no visible means of support and no permanent residence in our village. When he was booked he put himself on record with our citizens as a terrible fibber, claiming that he had the power to be in all parts of the world at the same time. He added that his permanent residence was the North Pole and on the police blotter his name appears as S. Claus. Not only has he made himself a favorite with the persons I have mentioned, but he has a strange attraction for dogs and when he is seen it is always in the company of a passel of pooches of various ages, mostly on the younger side. When he was questioned he said that he was keeping the dogs to give away to worthy homes at some future time. Nobody believed that because where I live nobody gives anything away. But oddly enough, come Christmas morning, here and there will be found a home that shelters a brand new dog, usually a puppy, and this is particularly common

if there are youngsters in that home. Now it wouldn't at all surprise me, if you wanted a dog, if you wrote to Mr. Claus and told him your preferences.

Yes, you will find a dog a gift of value to all members of the family—for many youngsters it is the gift supreme, a playmate and a continued provider of entertainment. What's more, a dog gives lessons in affection and if well trained affords examples of obedience and observance of good conduct. But children if given a dog should be taught that while it can be a playmate it should never be regarded as a plaything. To view the dog simply as an interesting, living toy isn't fair to the animal and it loses qualities of character that could cancel its usefulness to its owner and to the home that harbors it. However, as I have counseled in these pages before, unless the children are well controlled it is inadvisable to get a dog less than four or five months old. The only exception possibly would be if it is a dog of one of the larger breeds.

**V**ERY YOUNG CHILDREN seldom understand that a small puppy can be injured by rough handling so it is up to the parents to instruct the child. But the puppy or dog that is well advanced in months can be a source of joy and companionship for the child and the family for years after the usual gifts have been forgotten.

One of the questions most frequently asked of me is, "What breed of dog is best?" and my invariable reply to this is the breed you like the best or if getting the dog for a youngster if the child is sufficiently old to discriminate then the

breed would naturally be the one that the child likes best. But it must be borne in mind that there are certain necessary things to consider when getting a dog. Among these are the size of the living quarters, whether or not you have a backyard, and should you or the child have in mind a dog to serve a particular purpose, there too, breed selection is important. For those whose living quarters are cramped it stands to reason that one of the larger dogs such as the Great Dane, Newfoundland, etc. will make your living space more cramped.

Another consideration is the coat of the dog. Here it is well to bear in mind that some dogs shed continuously throughout the year while others go through a monthly or semi-annual shedding period; and the hairs of the long coated dog are likely to prove very annoying to the lady of the house who wants to keep her furniture and carpet in top condition. Also the hairs of a white coated dog, whether long coated or short coated, when shed naturally are more noticeable. If your living space is very limited I would suggest that one of the small terriers or toy dogs would be a happier choice in the matter of size. Many of the small terrier breeds are so active as to provide their own exercise and yet not be annoyingly conspicuous. If you have a backyard in which you can confine the dog, any of the middle size breeds such as the Kerry Blue, Airedale or the larger breeds such as the collie or Great Dane, will be happier and less conspicuous in your household.

If you are concerned about the breed it would be a wise matter to try to attend

*(Continued on page 36)*



---

---

---

# TRAVELGUIDE

---

---

---



Those of our many readers who will be going through or in or near Hollywood, Florida, will be interested to know about the Dillows Motel and Apartments, run by R. J. Whittinger. Directly across from the Elks Club, rates here are reasonable and you may enjoy many comforts and conveniences among friends and Brother Elks.

★ ★ ★

*"Florida Aflame", the drama of the Seminoles, at one and the same time a drama and a tourist attraction, is scheduled nightly in the Philippe Park Amphitheatre at Safety Harbor on Tampa Bay, Florida, from January 22 through April 17th next year. The drama traces the life of the Seminole nation from the peaceful days of the Spanish domination, down through the invasion of the peninsula by the white man to the final destruction of the nation at the hands of an invading army. As the army came in to remove the Indians to Oklahoma, the Seminoles stalked, sleepless through the swamps in search of safety and peace. Massacre followed betrayal and out of this struggle came tales, now legion, of the heroic deeds of Chief Osceola. This is the heroic story told in "Florida Aflame." Any traveler who reaches Clearwater, Tampa, St. Petersburg and vicinity should make a point of seeing this dramatic segment of Americana.*

★ ★ ★

Paul E. Conway (Davenport, Iowa, No. 298) reports, "We believe Sinclair Oil does a great job on its routing—theirs was the one which involved less driving and took in

most of the better points of interest along the route. Our hats are off to Sinclair's good people who take so much time to serve Elks."

★ ★ ★

*For those who plan to stop off at the Elks National Home in Bedford, Va., F. E. Connelly (Elmira, N.Y., No. 62) writes to recommend the Panorama Motel. "It is new and very nice. Good meals may be had there at reasonable prices. The picture window of their dining room affords a view of the Elks Home nearby on a hillside across the valley."*

★ ★ ★

For those going further south—to Cuba—Carl J. Peters (Nebraska City, Nebr., No. 1409) writes to say "I'd suggest that on arrival you consult one of the many guides who meet the plane. These are accredited guides from the Cuban Travel Association. We heartily recommend Mr. Mario Diaz, 352 Prado St., Havana, who will meet your plane on request. His services are the best and we know he will be liked by any Brother who employs him." If you plan a Havana trip writing to Mr. Diaz beforehand might be a good idea.

★ ★ ★

*Getting back to Florida, the Stephen Foster Memorial on U.S. 41 at White Springs is well worth seeing. The only charge is 25 cents for each car entering the grounds regardless of the number of passengers. Many travelers who have visited the Memorial have written to recommend it as a memorable experience.*

## For Elks Who Travel

(Continued from page 25)

Columbus discovered this one too; Nelson used it as a dockyard, and the U.S. used it as an air base for the Caribbean in 1940. The Antigua Beach Hotel has its beach and its own magnificent view of the coastline available from almost every room. As for the Lord Nelson Club, you can live and eat in your bathing suit since you can walk right out of your room onto the beach. One of the great attractions in Antigua are the steel bands, whole orchestras who play by beating cushioned mallets on oil drums. It sounds better than you'd think, and I believe you should know that the bands are called respectively, the Hell's Gate and the Brute Force Steel Band.

Whereas Curacao and Aruba are well

known bits of Dutch territory in the Caribbean, you will be more of an adventurer if you journey to Saba or to Bonaire. Saba is merely a volcano. You must go there by boat and debark in the surf. They like to say in Saba that every landing is an adventure. Then you must ride up the side of the volcano and over the top of the cone in order to reach a city sitting in the ex-volcano pit. It is called The Bottom. Saba exports men who become sailors, ship's captains, and seagoing engineers. Women outnumber men two to one on the island and they pass the time by fashioning fine sewing. It used to be the custom, too, for the men to build their longboats on top of the mountain and then slide them to the bottom, but if

Going North? In Quebec, the Laurentian Mountains rank high among the great winter sports areas of the Continent. For skiing, the snow conditions there are about the finest in the East. Fast special trains roll out of Montreal over two routes to this winter playland. It is equally easy to get there by plane, bus or your own car on a first class highway kept clear of snow throughout the winter by the Provincial government. The region abounds in resorts, lodges, cabins and chalets where accommodations are comfortable and suited to various sized pocketbooks.

★ ★ ★

*Pan American Air Lines announces a 30-minute sound and color film on Japan for showings to clubs, churches, civic groups and lodges throughout the country. The film attempts to give an insight into the character, customs and beliefs of the people as well as portraying the country from a scenic standpoint. "So Small My Island" may be obtained from Pan American offices free of charge throughout the United States.*

★ ★ ★

Mr. and Mrs. R. T. Edwards of Bakersfield, Calif., write to tell of their visit to Ensanada, Mexico in Baja California. They stopped at the Villa Marina at \$7.00 per night. They spoke highly of the food and entertainment at the Fiesta Club and were impressed by the newly built Cadillac Motel and its large swimming pool.

you see such practice today, count yourself lucky.

Bonaire is way back south in the Caribbean, near Venezuela, but it has escaped the tremendous commercialization of Curacao and Aruba. The capital is officially Kralendijk, a good Dutch name, but for reasons that escape me, it is often corrupted to Playa. In the tranquility of Bonaire you can commune with blue and white herons, pintails and pelicans, sandpipers and seagulls, and blush-pink flamingoes which nest here in profusion. Seabass, kingfish, sailfish, bonito, and pompano swim the waters, and there is plenty of activity for the spearfishermen and also for those who would see their fish from the dry comfort of a glass-bottomed boat.



## News of the State Associations

(Continued from page 15)

to be expanded; scholarship grants in therapy and teacher-training totaled an expenditure of more than \$50,500, medical research took \$5,000, new equipment cost \$10,000, and expense of operating the units, including salaries for their therapists, was nearly \$75,000, with executive and secretarial costs totaling approximately \$11,000.

State Pres. Edward E. Keller opened the business sessions at the San Francisco Lodge home with host E.R. John O'Kane, Mayor Elmer E. Robinson and Convention Chairman Henry J. Budde extending a hearty welcome. Past Grand Exalted Ruler Lewis escorted Grand Exalted Ruler William J. Jernick to the stage, and presented him to the capacity audience with a well-phrased introduction. Responding graciously, Mr. Jernick delivered a stirring talk stressing the important role Elkdom plays in its actions for civic betterment, such as the great California Project.

Reports revealed the healthy growth of Elkdom in the State—five lodges instituted in the year, and a net gain of nearly 10,000 members between April, 1953, and October, 1954, to total 111,300 Elks for Calif.'s 110 lodges. A most gratifying account of the outstanding work of the Veterans Service Committee, capably headed by Robert N. Traver, was well received and marked progress was

reported by the Americanization Committee. The delegates learned that three Elks National Foundation scholarships totaling \$2,300 had been presented with the Assn. granting one \$250 award and seven \$200 scholarships.

Mr. Lewis, who installed the new officers, introduced U. S. Senator Thomas H. Kuchel, a member of Anaheim Lodge and a forceful speaker. Assuming office for the year are Robert P. Mohrbacker, Long Beach, Pres.; Vice-President Alex Hansen, Riverside; Thomas Norton, Newport Harbor; Wallace Ericson, Glendale; Bruce Marsh, Inglewood; Paul Sanchez, Santa Maria; John Guerard, Fresno; Gerald McCormick, Pittsburg; Rawlins Coffman, Red Bluff. Trustees, filling expiring terms, are Edwin Hales, Redlands; Owen Keown, Santa Monica; James Reavis, Delano; Paul Wemple, Susanville. Edgar W. Dale of Richmond was reelected Secy. for the 15th time, and Robert Walker of Santa Ana will

serve as Treas. William Franklin of Big Bear Lake is Sgt.-at-Arms; Rev. David Todd Gillmor, San Jose, continues as Chaplain, and Walter Schween, Jr., Salinas, is Tiler. John A. Raffetto, Jr., and R. Leonard Bush were appointed to fill vacancies on the Major Project Committee, with C. P. Hebenstreit as Chairman and Mr. Wisely, recently named to the Board of Grand Trustees, as Vice-Chairman of this Committee.

Past Pres. Grocott presided at impressive Memorial Services when E.R. O'Kane offered the Toast and Past. Pres. Bush delivered the eulogy.

Eight Ritualistic Teams participated in the Contest won by Sonora over San Fernando, and Santa Monica took the 16-man division title in the Drill Team Contest, with Sacramento leading in the 12-man group.

The Festival of Music presented vocal units from seven lodges, with opera star Marilouise Rossini as soloist. Santa Monica's entry won the Band Contest over Glendale and Long Beach in that order, the Long Beach contingent visiting the Shrine Hospital to entertain the crippled children there.

Social highlight was the banquet attended by 600 persons who gathered to pay tribute to retiring Pres. and Mrs. Keller, with Grand Exalted Ruler Jernick and his wife as honored guests.

### Forthcoming State Association Meetings

No. Carolina	Raleigh	Dec. 9-10-11
So. Carolina	Anderson	Jan. 14-15
Michigan	Muskegon	Jan. 15-16
Md., Dela. and D. C.	Towson, Md.	Jan. 21-22
Montana	Shelby	Jan. 22-23

### In the Doghouse

(Continued from page 34)

a dog show where you will see adult sizes of the breeds you or the youngster may prefer; this will save you much future annoyance because very often the larger breeds, while they are puppies, give little indication to the uninitiated of the size to which they will eventually attain.

When buying your dog it is well to get it from a kennel if you want a pure bred. The price, of course, is likely to be higher than that asked by a random breeder; but when you consider a dog given reasonable care will live twelve to fourteen years, such investment as you may make, spread over the years, actually amounts to very little; and you will find that reputable kennels do not breed from unhealthy or nervous stock. If they did, they would soon go out of business as kennels. Should your local news dealer sell any of the better known dog magazines, it is well to pick up a copy and look through it for kennels advertising dogs for sale. When buying at a distance you need have no fear because in these days of rapid transportation dogs do not have to spend much time between leaving the kennel and reaching your home.

If you open correspondence with a kennel with an eye to purchasing a puppy or a dog, be sure to specify the age of the dog, decide what sex you want and if

important to you, its color. You might even ask that the kennel mail you a snapshot of the dog or puppy it wishes to sell. Inquire, too, whether the dog has been inoculated against distemper and rabies and ask the name of the veterinarian who administered the inoculations. If you can see the dog before purchasing it there are a few simple things to look for to assure you are getting an entirely healthy animal. Avoid the dog that has a foul breath as this may indicate digestive disorders which can later involve you in veterinary expense. Look under the dog's forelegs and on its stomach and inside its ears for evidence of rash which may be the forerunner of a persistent, annoying disorder of the skin which may require the attention of a veterinarian. See that the white of the dog's eyes are a clear white and not cloudy. Watch the dog or puppy, if you can, when it is with its kennel mates and you will be on the safe side if you pick the animal that seems to be a little more aggressive than its companions. By aggressive I don't mean sharp tempered but merely alert and lively.

So far, I have discussed the kennel dog which you may purchase but there is no reason why you can't find a dog of your preference in an animal shelter that

may be in your vicinity. Not only can you get a dog of your choice at very little cost (as some shelters ask only a nominal fee and some nothing at all) but you will be doing a humane thing to open your home to such a waif. There is a common but mistaken belief that the mongrel is more intelligent and healthy than the kennel dog. This is not entirely correct, for intelligence and health are determined by the genes of the parents.

If there is ill health, mental or physical, among the parents of the dog they may well appear in the dog of today. Yes, there is such a thing as mental ill health or psychosis among dogs, although this condition is rare because dogs live healthier lives than some people. But on the whole, the kennel dog is more likely to be mentally and physically fit. To the kennel owner that dog represents an investment of much time and money spent on breeding and producing puppies, which means that kennel owners carefully study breed lines and character of the dogs from which they want to breed.

Naturally, a kennel owner does not want his establishment to become known as a producer of canine fatheads or neurotics. On the other hand, the mongrel represents a survival of the fittest because he comes from a background of



dogs who had to struggle for a living and who had to remain well while the ill among them died neglected. Kennel owners are quick to call in the services of a veterinarian when their dogs become ill and many of the larger kennels employ kennel managers who are practically veterinarians themselves. If yours is not a pedigreed pooch don't make the mistake, as many do, of assuming an apologetic attitude when talking about your dog. In such matters as affection, courage and loyalty the mongrel matches the pure bred almost every time.

Don't, as many do, shy away from selecting a female. As I have frequently told correspondents who write to me for advice on selecting a dog, the female gives everything that the male can give as a housepet, and more. She is less likely to roam from her home in search of adventure; and being a female she is more likely to be jealous of her home and her sense of possessiveness thus frequently makes her a better guardian. The semi-annual periods of romance which afflict her can be easily controlled with a little vigilance on your part. She'll only think of romance twice a year and at such times should be strictly restrained in one of your lesser used rooms or a warm dry cellar. And at no time should she be permitted to run loose for exercise but should be walked on a leash; and if she is not too big to hold in your arms, it is a good idea to carry her about 150 feet from your home when leaving it or returning to it. This will break the scent trail which she may leave. In doing this you will avoid having your home a stopping off place for canine gallants in search of romance.

**W**HEN YOU get your puppy or young dog, whether from a kennel or a shelter, don't forget you are introducing the dog into a wholly strange environment and do not be concerned if, for the first few days, the dog is shy and seeks to avoid people. To him your home is likely to prove just as strange as you would find a sudden transfer to the planet Mars. All things are likely to be new to him, your carpets, your furniture and even the ordinary sounds of the household; but most dogs quickly adjust themselves and many of them before long become important members of the home. Dogs adjust themselves more quickly than most human beings and are more philosophic in their acceptance of new conditions. Your new dog should have a quiet, darkened sleeping place and should not be handled by too many members of your family or such visitors as you may have. Loud sounds and sudden movements in the vicinity of the dog should be avoided. Your pup should immediately have his eating and drinking place established and once this is done, until the dog has become thoroughly familiar with your home, that place should not be changed. And now—Merry Christmas from your dog writer.

## Since 1926! The Halvorfold

Loose-leaf Pass Case, Billfold, Card Case. Note exclusive features. Read Special Offer below



Now with TOOLED ELK EMBLEM on outside front

## "Made to Order" for ELKS

NOW in its 28th year—THE HALVORFOLD, bill-fold, pass-case, card-case. Just what every ELK needs. No fumbling for your passes. Just snap open your Halvorfold and they all show each under separate, transparent, acetate face protected from dirt and wear. Ingenious loose-leaf device enables you to show 8, 12 or 16 passes, membership cards, photos, etc. Also has three card pockets and extra size currency compartment at back.

Made of high grade, smooth, black or brown Genuine Calfskin, specially tanned for the Hal-

### Free Examination!

**Send No Money—No C. O. D.**  
Read my liberal offer in coupon. No strings to this. Just send the coupon and your Halvorfold comes by return mail. No. C.O.D.—no payment of any kind. Examine the Halvorfold carefully, slip in your passes and cards and see how handy it is. Show it to your friends and note their admiration. Compare it with other cases at more money. My price to you is only \$9 (\$7.50 without gold trim), tax included. No obligation to buy. I trust Elks and all the Mrs. Elks, who buy Halvorfolds from me annually for Christmas and Birthdays for Husbands, Brothers, Family and Friends, as square-shooters. And I'm so sure the Halvorfold is just what you need that I'm making you the fairest offer I know how. The Halvorfold is also available without Tooled Elk Emblem. Don't miss this chance. Send coupon today.

vorfold. Tough, durable and has that beautiful soft texture that shows real quality. All nylon stitched, extra heavy. Gold filled corners and snapbutton. Size 3 3/4 x 4 3/4 inches, just right for hip pocket. Backbone of loose-leaf device prevents breaking down. You can't wear out your Halvorfold.

**FREE** in 23-K Gold, your name, address, any emblem and lodge. This would ordinarily cost you \$2 to \$2.50 extra. An ideal gift with your friend's name, address, etc.

**HALVORSEN, P.C.M.—Station G, Jacksonville, Florida (Dept. 68)**

Send me the Halvorfold for free examination, with my name, address, etc., as per instructions below, in 23K Gold. If I decide not to keep it, I will return it at your expense within 3 days and call the deal closed. If satisfied, I will remit your special price of \$9—or \$7.50. (Halvorfold comes for 8 passes. For 12-pass add 25c—16-pass add 50c.) For mutual protection mention here your lodge and number.

Name.....  
Address.....  
Address.....  
**5%** Off to save bookkeeping, if you prefer to send cash with order. Money back, of course, if not satisfied.  
Chk. here:  Black  Brown  Gold Trim  Tooled Emblem  Plain  Without

**Breed RARE TROPICAL FISH**  
AT HOME!—FOR SPARE-TIME PROFITS!  
HELP US FILL HUGE DEMAND... Wonderful \$\$\$ opportunity!... fascinating hobby! EARN BIG MONEY in your home. No experience, no expensive equipment needed. WE SUPPLY EVERYTHING! Breed Tropicals that "Light Up"—are "12 radiant colors" that are striped like "Zebras", etc. Some very rare Tropicals SOLD FOR \$75.00 PR. AND MORE! New fabulous "HOME-BUSINESS". Investigate! WRITE TODAY, stating your age. Illustrated Plan, Reprint, Colorful Brochure, etc. Write **TROPICAL FISH BREEDERS OF AMERICA**, Dept. JC, 15127 S. Bdwy., Los Angeles 61, Cal.

**Stop KILLING yourself shoveling SNOW**  
Save your heart and back. Get Rid-O-Sno, sturdy steel plow. Spring adjusted blade 30"x12" pushes snow left, right, forward. 6" rubber wheels hug ground. You clean walks, driveway, in minutes! \$18.75 postpaid. Money back in 5 days if not delighted. W. of Miss., add \$1; N. Y. C. residents, 3% tax. Send check or money order. Ideal gift!  
**LEISURE INDUSTRIES, Dept. 65**  
96-09 Metropolitan Ave., Forest Hills 75, N. Y.

**A RECORD OF GREAT DEEDS—A PERFECT GIFT**  
Every Elk will be proud to own and read the "History of the Order of Elks." It tells how the Order was established, records Elks accomplishment and tells why Elkdom continues to flourish and grow. Ideal Christmas gift for every member of the Order. Beautifully bound with blue leatherette cover and gold lettering; 432 pages profusely illustrated. \$3.67, including shipping. \$3.78 within N.Y.C. Send orders to Department E, THE ELKS MAGAZINE, 50 East 42nd Street, New York 17, N. Y.

**WANT \$10,000 YEARLY?**  
Others make this and more raising Chinchillas. Basement or spare room starts you. We furnish starting stock... buy all you raise.  
**NATIONAL CHINCHILLAS, DEPT. 10**  
7372 Melrose Avenue, Los Angeles 46, Calif.

**TODAY.. write for folders.. no obligation**  
**ETERNAL BRONZE**  
MEMORIAL PLAQUES, signs, honor rolls, add-a-plate tablets of handsomely hand-chased cast bronze... famous for finer craftsmanship since 1882.  
**Newman Bros., Inc.**  
Dept. 722, Cincinnati 3, O.

**Become an ACCOUNTANT—Expert Bookkeeper—C. P. A.**  
The demand for skilled accountants—men who really know their business—is increasing. National and state legislation is requiring of business much more in the way of Auditing, Cost Accounting, Business Law, Organization, Management, Finance. Men who prove their qualifications in this important field are promoted to responsible executive positions.  
**FREE SAMPLE LESSON**  
Knowledge of bookkeeping unnecessary. We train you from ground up, or according to your individual needs. Low cost; easy terms.  
Send name and address on the lines below for free Sample Lesson and 48-page book describing the LaSalle accountancy training and the opportunities in this highly profitable field.  
**LASALLE EXTENSION UNIVERSITY**  
*A Correspondence Institution*  
417 S. Dearborn St., Dept. 12328H, Chicago 5, Ill.  
Name.....  
Address.....  
City.....Zone.....State.....



## Choice of Weapons

(Continued from page 5)

"Hogan!" the Tinsmith's handlers began to complain. "Where is Hogan?"

"I'm over here," the young man said.

"Then, come, man! Come now!" it was demanded.

"I'm in no hurry," Dan Hogan, the policeman, said. "Why should a man be in a hurry to have the brains crushed in his head?"

"That's no spirit at all, lad," he was cautioned.

"Well, then," said Hogan, "tell me this—whose head is it, yours or mine?"

He walked indolently from the barge to the level beyond the shoreline where the ring was pitched. He held a heavy blanket around himself and he laughed when they said he looked more like a horse or a wild, crazy Indian than a fighting man. He was twenty-three years old and a Bowery constable through the appointive power of Tammany Hall. It was said with some accuracy that this Hogan was a lad who knew how to take care of himself. The Tinsmith, standing in the ring, looked perplexed and cold.

"Into the ring with you now, Hogan!"

"Just a minute, please," the lad said. "Don't be pushing an officer of the law. I have a little money of my own and I would like to place a bet." He did not, like the Tinsmith, wear the scars of his avocation. When he smiled, the effect was disarming. He gazed now to the barge where a clique of gamblers were unblushingly waving their money.

"What are the odds?" he asked. And the word came back: "It's four to one the Tinsmith smashes you, lad."

"Then I suggest that you gentlemen come forward with your money," Hogan said.

ON THE FAR SIDE OF THE INLET, where the small boat had been moored, the girl was waiting. Restlessly each now and then she would pace the narrow strip of sand with stylish grace, raising all three petticoats the necessary bit. A small man with a twisted nose sat on a stone nearby. Once, dramatically, he spat tobacco juice at a horseshoe crab.

"Excuse me, ma'am," he said to the girl, "for missing the ugly creature."

Her name was Mary Richards, and she smiled, but she didn't reply. He noted how she held the lace kerchief a bit too tightly in her hands. She was about nineteen. Her hair was the color of the melting sky. She had the posture of a queen and it was fitting that she should become the bride of Hogan.

"I will say this for you, ma'am; you brought your courage with you," the small man said.

"Thank you, Jed. It may be that I'll need it."

"Not that your father would hurt a hair of his own blood daughter, but believe me, ma'am, and God help us all,

what he wouldn't do to young Hogan, if he knew the thing you planned."

Mary Richards nodded her solemn agreement. She had stopped her restless pacing. "Ned," she asked, "do you think we'll like it in the west—Dan and I?"

Ned Deever looked puzzled. "I dunno. I understand the women have the vote in Wyoming now, which only goes to show that it must be a highly uncivilized place. No offense meant, ma'am, but it's the damndest thing I ever heard. The vote for women and whiskey for the Indians. Why should a territory like that one expect to become a state?"

Mary laughed. "Have you ever been to Wyoming, Ned?"

"No, ma'am. Only California-aye, by ship that time. I was there with Dan two years ago—him as much an easterner as me. It seems they were all out of gold, so he comes home and gets on the cops."

"Was Dan—well, was he fighting then?"

"Not in a serious way, ma'am. Only thing I remember is he sparred a few rounds with a young bank clerk named Corbett—just for the sport of it, mind you, with gloves, and while I might be prejudiced about Dan, it was hard to tell which lad was quicker with his hands—him or this Corbett."

The first great roar of the crowd came at them from the distance of a quarter mile. The girl's face paled, her eyes flashed with alarm.

"Does that mean they're fighting now, Ned?"

"Yes," he said, "they're at it now—as sure as your father is Commissioner of Police."

He watched this girl shrewdly and was pleased with what he saw. She was taking punishment, no doubt of that, but she would not be lacking in a time of trial.

"Why," she demanded, "did he have to fight a man as powerful as this one?"

"For money," Ned Deever said calmly. "It's such a useful thing for a bridegroom to have, ma'am, when he's running off with a girl like yourself that's had all the advantages. Would you want him to be what your father already has called him—a worthless and penniless rogue?"

"I never asked that he be rich, Ned, and I'd rather have him penniless than senseless." She stopped then, for the crowd roar swelled anew and shook the forest behind them. Only the waters of the bay were calm. The small boat drifted at anchor.

"The difference between us, ma'am," Ned Deever said, "is that you never saw Dan Hogan fight."

★ ★ ★

In the Territory of Wyoming, where the women voted, and the cattle, in the good years, grazed as plump as Grover Cleveland, it could be said with truthfulness that no one within a thousand miles

had ever seen Dan Hogan fight. This was a peculiar thing, in fighting country. Most people had grown to like Dan Hogan in the year and more he had been here. Still you could not avoid the feeling that any ranchman, in the prime of his life, who didn't carry sidearms in the year of '88, was either a misplaced person or—let's face it, citizens, a man afraid of a fight. There'd been a fellow named Deever, a small man with a twisted nose who, when he was drinking, had told fanciful, unlikely stories of this mild man from the east—how he could hit you as fast with either hand as a bobcat could with its paws, but that was just saloon talk, anyhow; folks out here didn't fight with their fists and God had yet to make the man whose hands were as fast as a Colt .44. This fellow Deever, a funny kind, had gone back home, lonesome for the Bowery, he had said, and for the kind of beer, chilled in the keg, that a man couldn't get west of Chicago or east of Frisco.

"Good afternoon, Dan."

"'afternoon, sheriff," Hogan said.

HE NO LONGER looked like an easterner. The sun had fried the pink Irish look right out of him and painted the exposed parts of his hide mahogany. The boots he wore had raised his natural six feet just a little closer to the sky. He stood with the sheriff in the dust of the late day, making small talk outside the sprawling, crude-lumber saloon known as the Cattleman's Rest. Sheriff Manion's thought right now was that this man, so popular in town, was tailor-made for deputization—the Lord knowing how much help was needed; but then you looked at his lean hips and the absence of sidearms and you concluded, naturally, this was no fighting man at all; hell, this was not even a man prepared to protect himself or his own.

"How's the lady, Dan?"

"She's real fine, sheriff. Happy as flies on a sugar mule."

"And the youngster?"

"He's comin' along," Dan said. "He was four months old the other day. We put him on a grain scale and he pushed it up to twenty pounds."

"You like it here, Dan, don't you?"

"Well, what do you think?" the big man said.

It was a funny thing about this mild and unarmed rancher from the east. He'd tell you straight to your face that up until some fourteen months ago all he had known about beef was what he had learned with a knife and fork. But it made you wonder why, of all the spreads in this part of the territory, only Hogan had been able to coast undamaged through the killing winter of '87-'88. Some said it was because his herd had been small and, for that reason, capable



of management; besides, they said, he'd had the damfool luck to have on hand just hay enough to keep meat on their bones till spring, then watch the price of beef go higher than a gas balloon. Sheriff Manion, however, with a few other people, had a notion all of it was not pure luck.

"Hyman Ranse was out your way last week, Dan?"

"Who?"

"Ranse—Hyman Ranse," the sheriff repeated. "The real big feller from Cheyenne. I heard for sure he was out there. He wanted a few little items you got nailed down. I'm right about that, Dan?"

"You could be right, sheriff. Matter of fact, he wanted to buy a bull I got—a bull named Tammany Hall, and a couple of special cows. He offered a nice price, sheriff."

"And what'd you say?"

"I told him, 'No.' I told him how it was with Tammany Hall; that he's a father steer with a lot of rabbit in his heart and that we have to think of future generations."

"Did he like it?"

"No," said Hogan, "he didn't like it. It seems his own herds took real punishment last winter. He's a real possessive man."

"Did he threaten you, Dan?"

"Now, sheriff, please—let's not get talkin' foolishness. You know I never argue with anyone out here. All you people got those great big firin' rods and I'm afraid of them."

"Is that why you don't carry one, Dan?"

"That's right, sir."

"And what other reason?"

"Maybe the other reason is that I wouldn't like shootin' people any more than I would like to have them shootin' me."

"You've got a family to protect," he was reminded.

"I know that, sir. I know that all the time. Let me buy you a drink."

**T**HE SHERIFF said no, not today. The sheriff, like the county doctor, had his everlasting rounds to make. This town one day, another the next, until the whole wide county had been covered, and nothing, absolutely nothing, accomplished.

"Can't stay long enough in one place to get my shirt washed or to shoot a mad dog," Manion complained. "I could use a man like you, Dan, as a kind of deputy, if you wasn't so damned ascaered of guns. I've got a few men in the other towns."

"I'd be the wrong man, sheriff."

"That's what I was thinking," the older man said sadly. "Folks like you, Dan, but the question is—do they respect you?"

Manion left him then and Hogan watched the buckboard make the last turn out of town. The day had run most of its length. The sky was like a strawberry pie and the distant hills were blue.



# Monroe FOLDING BANQUET TABLES

If you are on the board of your church, school, lodge, club, P.T.A., etc., you will be delighted with our new MONROE Tables. NOW, at no extra cost, offered with completely finished tops, highly resistant to most serving hazards. USED WITHOUT TABLE CLOTHS. Send for catalog with direct factory prices and money-saving discounts to institutions.



MONROE Trucks No. T58

## MONROE TRUCKS

### For Folding Tables and Chairs

Transport and store your folding tables and chairs the easy, modern way on MONROE Trucks. Construction of Transport-Storage Trucks permits maneuverability in limited space. See Catalog.



Complete Line of Folding Chairs

**THE MONROE COMPANY**  
90 CHURCH STREET COLFAX, IOWA

# No More Dangling Cord For Hearing Aid Users ?

It's true! Thousands of users have found it possible to wear the new Transist-Ear neatly in the hair. Remarkable new tiny instrument that weighs hardly more than an ounce makes practical a completely different kind of wearing. As soon as you try it, you'll hear sounds more naturally. You'll know where sounds are coming from. You'll en-



L. A. WATSON

joy a complete clarity of sound. Here is what the hard-of-hearing have been waiting for. Will you spend one minute of your time and a three-cent stamp to get the amazing facts about this new kind of hearing? If so, send in coupon at once. It will be the turning point in your life of sound.

MAICO CO. Rm. 16D  
21 N. 3rd St. Minneapolis, Minn.

NAME \_\_\_\_\_  
ADDRESS \_\_\_\_\_  
CITY \_\_\_\_\_

**LEARN TO THROW THE BOOMERANG**  
A Fascinating Sport and Unique Gift

SEND FOR YOURS TODAY

Flight Tested - Guaranteed to Return Golden Red, Jade Green or Natural with Story and Instructions \$2.00 ea. Postpaid

**CARVED by COL. JOHN M. GERRISH**  
4409-K S. W. Parkview Lane-Portland 1, Ore.

**"SHOOPER" GEIGER COUNTER**

Super-sensitive! Only 1 1/4 lbs.! Fits pocket—uses flashlight battery. Find a fortune in uranium. Order Now! Send \$5.00, balance C.O.D. MONEY BACK GUARANTEE. FREE CATALOG—scintillator and larger uranium and metal detectors. DEALERS WANTED.

**2995 COMPLETE**

**PRECISION RADIATION INSTRUMENTS**  
2235K S. La Brea, Los Angeles 16, Calif.

**I'll Send You This Handsome SAMPLE CASE - FREE**

and Show You How to Make Up to \$30.00 in a Day

WRITE for this FREE Tailoring Sample Case packed with 150 beautiful, big-value suit and overcoat fabrics. Take orders from friends, fellow-workers, others, for fine quality made-to-measure clothes. Pocket big cash profits in advance. Because wearing our suits and overcoats brings more orders, we make it easy for you to get your own clothes without the cost. No experience is needed. SATISFACTION GUARANTEED. SEND NO MONEY. Rush your name, address, and age—today!

**W. Z. GIBSON, INC., 500 South Throop Street DEPT. U-444 CHICAGO 7, ILLINOIS**

**LAW FREE BOOK**

Write today for FREE book, "THE LAW-TRAINED MAN," which shows how to learn law in spare time through the famous Blackstone home-study course in business and professional law. All instruction material furnished including big 16-volume law library. Bachelor of Laws (LL.B.) degree awarded. Moderate cost; easy terms. Write today.

**Blackstone School of Law, 225 North Michigan Ave. Dept. 119, Chicago 1, Ill.**  
Founded 1890

**REAL ESTATE BE A BROKER**

PAYS BIG! SEND FOR FREE, BIG, ILLUSTRATED CATALOG NOW! Graduates report making substantial incomes. Start and run your own business quickly. Men, women of all ages, learn easily. Course covers Sales, Property Management, Appraising, Loans, Mortgages, and related subjects. **STUDY AT HOME** or in classrooms in leading cities. Diploma awarded. Write TODAY for free book! No obligation. Approved for World War II and Korean Veterans

**WEAVER SCHOOL OF REAL ESTATE (Est. 1936)**  
2020 Grand Dept. BOE Kansas City, Mo.

**DINSMORE... AUTO COMPASS**

Enjoy traveling with America's finest auto compass. Accurate—dependable—trouble-free. Quickly and conveniently mounted on any car.

Always insist on a DINSMORE—It's the only compass approved by auto manufacturers.

Send for free folder "Pants, Knives, Compasses" and name of nearest dealer.

**GUIDE-WAY \$4.49**

Non-Illuminated

**TRAVELITE only \$5.49**

**Dinsmore Instrument Company**  
1812-39 Kelso St. Flint, Mich. Illuminated



# Polio is NOT Beaten



Mary Kosloski, 1955 March of Dimes poster girl, is five years old and from Tennessee.

My Brothers:

We face a crisis in our struggle for a better America.

Next month, the National Foundation for Infantile Paralysis will ask the citizens of the United States to contribute \$64,000,000 to the March of Dimes. Every penny of this huge sum is needed to care for polio's past victims, and to make sure that polio will claim no more victims in the future.

What makes this a critical moment in the war on polio is the widespread notion that the war is over. The great publicity given to the field tests of a polio vaccine last spring and summer has led many people to assume that there is no more need of their dimes, and this attitude threatens defeat just when the hour of victory seems to be dawning.

Here are the facts. We won't know until next April at the earliest whether the Salk vaccine tested last spring will be truly effective. Taking a calculated financial risk, the Foundation has ordered 9 million dollars worth to have on hand for vaccinations next year if it proves effective.

The Foundation ran up a deficit of about 10 million dollars (even after the emergency appeal earlier this fall) to pay for those field tests and to provide gamma globulin injections during last summer's polio epidemic.

There are about 60,000 children and grown-ups, stricken with polio, who must be taken care of by us. Are we go-

ing to forget about these cases carried over from other years? Are we going to say, "Stop the iron lungs and the rocking beds. Let these people die?" Or, are we going to raise the nearly 30 million dollars needed to save them.

Much more equipment has to be provided. Many more physical therapists have to be trained. There is an enormous amount of research yet needed.

No! The war on polio is not finished. We are at a critical point in that war, and I am asking the Order of Elks to move into that crisis as we have moved against other crises in the past. I want every Lodge of Elks to accept direct responsibility for the success of the March of Dimes campaign in its community next month.

Give, of course, as all of us will. But let that be just the beginning. Take the lead in this campaign. Mobilize your manpower, your wonderful leadership, all of your resources, and throw them into the battle that must be won. The Elks have always been a mighty supporter of the March of Dimes. We cannot and we will not quit now, when victory is in our grasp.

Faternally yours,

*William Jernick*

A low wind bent the tall grass for a hundred miles, sweeping its sweetness over the town. It was almost too nice an evening for a man to have a drink but sociability seemed to demand it. He walked into the Cattleman's Rest.

"Dan'l, my lad!" the bartender greeted him.

It was nice to be known by so many, Dan thought, and better still to be liked. He sipped one finger of whiskey at the bar, foregoing his usual warm orange

phosphate, a concoction that made the bartender wince and had almost driven Ned Deever out of his mind. Dan, of course, missed Deever, as did most of those who had gotten to know him at all. "Nice evenin' outside, Dan'l?"

"It's real nice, George. There's a breeze like lilacs."

"Well, it smells in here."

Dan didn't mind. The stale heat of the afternoon hung heavy in the rafters. It made you sweat while you were stand-

ing still. It made you bless the breadth and freedom of the out-of-doors. Yet there was sociability to make the night worth while. There was ranchman's talk and condemnation of the sheepmen everywhere. A dozen card games, big and small, were tensely underway. Dan saw Hyman Ranse, the cattle speculator, sitting in the biggest of the games, driving his luck like a tired herd, pressing and pressing, forcing the game. Dan wandered into the circle of idle witnesses. It was easy to see that Ranse played well. When the cards came at him in wretched combinations, he read them skillfully, then played with shrewd daring. It was a five-handed game of five card draw and it was simple to see that two of the players were out of their depth—afraid not only of Hyman Ranse, but as well of his cash resources. A rancher named Shields, a slender, quiet man whom Dan knew fairly well, seemed equal to the challenge of Ranse's skill. Dan walked around and looked without comment at his hand, precisely as he had at the hands of others in the game.

"'evenin', Dan," said Shields, not looking up.

"'evening, Clint." Dan gazed at Shields's cards with legitimate curiosity. "Let the man play his own cards,"

Hyman Ranse said crisply. His glance met Hogan's and it held no compromise, nor any sign of friendliness.

"I don't think he needs help," Dan said quietly.

The moment passed and Dan's thoughts moved beyond the caprices of the game being played. His own experience was that the west had been friendly, if blunt, and he had no complaint against the majority of ruggedly frank yet decent men with whom he had been dealing. But Hyman Ranse?

"Your deal, Shields," Ranse said coolly.

It was hard to explain how a man could be offensive making a statement this plain. A funny thing, Dan thought, how Manion, the sheriff, had first brought up, then pressed the subject of this man. There had been trouble the other day; there'd been Ranse's greed (based, incidentally, on sharp analysis) for the things that Dan possessed. Ranse had not enjoyed the experience of finding his money ignored. There'd been words, too—not such a hellish lot of words, but more than Dan had told Manion.

Hogan, with his thoughts absorbed by these recollections of Ranse, was never sure how the crisis had bloomed and come to flower in the fetid air of the Cattleman's Rest. He simply knew that silence had fallen, as heavy as damped-down dust, and that the nervous, high-pitched, yet unflinching voice of Shields was responding to some kind of ultimatum. The words themselves demanded a decision:

"Do what you want about it, Mr. Ranse. I played it my way, and the hell with you, Mr. Ranse."

The hair began to rise on Hogan's



neck. It was a thing to be sensed, far more than understood. Hogan's heart, a sentimental article at any time, went automatically to Shields, who sat, pale-faced and sweating, yet, in his way, unflinching, facing Rance across the table. The moment was here and there was no way now to buy it back. The thump of an old clock filled the high, bare building with a strange throb of its own; the clock was like a heartbeat; men were still. Rance shoved the table violently against Shields's chest and with the same fluid motion came to his feet. His hand reached for his gun.

Hogan had known that Shields would not have a chance. His own response was instantaneous, without thought or plan. He simply chopped with his fist in a lightning stroke at Rance's jaw, sending the man and chair and half-drawn .44 their separate ways. Rance landed on his back, the sawdust and accumulated filth attaching to the fine silk blouse he wore. His huge hands clawed with hunger for the gun no longer in his grasp. His eyes were heavy with hate. The corners of his mouth were puffed with froth. Dan knew instinctively that there could be no easy exit from the situation. He stepped between his victim and the fallen .44.

"I don't like guns, Mr. Rance. They're much too dangerous. They frighten me."

The blood came in a thin stream now from Rance's mouth. Behind his wrath, bewilderment was rising. He was not sure how he had been hit, or by what lightning instrument. Hogan obligingly tapped his own right hand with the fingers of his left. "I'm really sorry, Mr. Rance," he said, then walked to the bar, aware that, while he remained unarmed and had a hundred witnesses, he would not be shot in the back. He took three fingers of whiskey and felt its burning glow in his chest. He tried not to cough from the unaccustomed strength of it. He smiled in amusement at the bartender's trembling hands. Now men came cautiously his way, closing a tight circle around him, cutting him off from Rance's view.

"You know what you done was stupid, don't you, Dan?"

"I suppose so, George."

THE BARTENDER looked like a man about to cry. He had a quick drink in support of his lagging spirit, then another. He raised the second drink in solemn ceremony.

"To you, Dan," George said woefully. "You had to pick on a man who could shoot the lint off a blue serge suit. Well, you were a real nice feller. Here's to you an' your widow."

He did not drink alone.

Hyman Rance pushed slowly through the crowd. His face was white, but not from fear. He placed a Colt .44 on the surface of the bar. His fingers had a loving touch for it.

"Wear one of these tomorrow," the

cattleman recommended softly, "or take the four o'clock stage out of town."

"And if I don't?" Dan said.

"Then armed, or unarmed, Hogan, I'll shoot you dead where I find you." He was a tall man, rangy and hard, with a mustache thin as a pencil line. "It's a way of life we've had out here for thirty years before you came," said Hyman Rance. "It won't have changed by tomorrow."

DAN HOGAN had never seen a dawn more beautiful, nor heard the tall grass whisper more endearingly. The time of comedy was over. There was no longer point or profit in pretending to Mary that Rance's ultimatum had been rendered in rage and for that reason was not binding. They both knew better. The town had known it the night before. By this afternoon the whole wide county would be knowing it. Nor was there any sense in wishing Sheriff Manion would come back from Little Storm or Bruceville or whatever town was being graced with his authority. The fact was that a man like Manion dealt almost exclusively with thieves, pernicious drunks, bad Indians and men who beat their wives. Personal affairs, such as his own conflict with Hyman Rance, were rarely if ever the subject of a sheriff's intervention. The code of the west was still a good bit stronger than a badge. It brought to Dan's mind now the thing that Manion had said: "Folks like you, Dan, but the question is—do they respect you?"

"They're insane," said Hogan, talking to himself.

He had been awake long ahead of daylight. He had two reasons for resisting a gun-duel with a man like Hyman Rance. The first was moral. He did not believe in murder, especially his own. Nor did he believe that men could long live separated from the decencies and balances of law, leaving their decisions to the six-gun. That would change and better years would come; meanwhile, he would like to live a while. His other reason—and the one that had amused him once, was the simple fact that, taking dead aim with a .44, he would be lucky to hit a standing cow at twenty yards. He could remember sharing this grim joke with his friend Ned Deever. Shooting at bottles, old jugs and a target the size of a horse, they had accepted the weight of the evidence: they were undoubtedly the two poorest shots in the west. He could remember Ned's final verdict: "You'd never have been a cop in New York, if it wasn't for Tammany Hall."

It was not funny now.

Mary didn't speak of it through breakfast, though the fear was in her, deep and lively. That much he knew. A feeling of doom, expressed far more in mood than in words, had taken hold of the ranchhands Dan employed. There were seven of them—rough, profane, ungifted, loyal. They took for granted he'd be meeting Hyman Rance that afternoon. It wasn't in them to believe that he would meekly,

"THIS IS THE BEST DEAL I EVER HAD—  
**I made \$36<sup>12</sup>  
in 2 hours**"

Selling Science's New Midget Miracle "Presto" Fire Extinguisher says A. E. Paugh, Greeley, Colo. Many others "cleaning up"—so can YOU!



A. E. PAUGH



Science's New Midget Miracle "PRESTO"

AMAZING new kind of fire extinguisher. Tiny "Presto" (about size of a flashlight) does job of bulky extinguishers that cost 4 times as much, are 8 times as heavy. Ends fires fast as 2 seconds. Fits in palm of hand. Never corrodes. Guaranteed for 20 years! Sells for only \$3.98. Over two million sold!

Show it to civil defense workers, owners of homes, cars, boats, farms, etc., and to stores for re-sale—make good income. H. J. Kerr reports \$20 a day. Wm. Wydaliss, \$15.20 an hour. Write for FREE Sales Kit. No obligation. (If you want a regular Presto to use as a demonstrator, send \$2.50. Money back if you wish.)

MERLITE INDUSTRIES, Dept. 1212, 114 E. 32nd St., New York 16, N. Y. IN CANADA: Mopa Co., Ltd., 371 Dowd St., Montreal 1, P. Q.

**HOW TO CHOOSE A  
BRONZE PLAQUE**

FREE illustrated brochure tells how—shows original ideas for reasonably priced, solid bronze nameplates, awards, testimonials, honor rolls, memorials, markers



Write for **FREE Brochure A**

For trophy, medal, cup ideas ask for Brochure B.

**INTERNATIONAL BRONZE TABLET CO., INC.**  
DEPT. 40—150 WEST 22 ST., NEW YORK 11, N. Y.

**LAW...**

**STUDY AT HOME** Legally trained men win higher positions and bigger success in business and public life. Greater opportunities now than ever before. **More Ability: More Prestige: More Money** We guide you step by step. You can train at home during spare time. Degree of LL.B. We furnish all text material, including 14-volume Law Library. Low cost, easy terms. Get our valuable 48-page "Law Training for Leadership" and "Evidence" books **FREE**. Send NOW. **LASALLE EXTENSION UNIVERSITY, 417 South Dearborn Street** A Correspondence Institution Dept. 12328L Chicago 5, Ill.



**Reflexite**

**AUTO EMBLEM**

3 1/2" Emblem in 5 colors. Stainless Steel frame. Attaches to license plate. Shows up clearly day and night.

**Price each, prepaid \$1.50**

**RUSSELL-HAMPTON CO.**  
303 W. Monroe St., Chicago 6, Ill.

**READY CUT HOMES**

**\$2150 AND UP DIRECT FROM MILL**

**YOU SAVE** the items which help make today's building cost expensive: high labor cost, contractor's profit and overhead, insurance, architect's fees. Cut-to-Fit eliminates usual lumber and material waste, also costly mistakes. Anyone can assemble. Simple, easy-to-follow plans furnished and each part numbered. Complete with all lumber, roofing, nails, glass, hardware, paint, doors, windows. Freight paid. Low-cost plans sold separately if desired. 57 Homes and Floor Plans.



**5 EASY PAY PLANS  
COLOR CATALOG**

Send **25c** for **Starting Home**

**INTERNATIONAL MILL & TIMBER CO.**  
Dept. EL-124 Bay City, Mich.



with his wife and son, climb on the stage to Bruceville, Lonely Pasture, Cheyenne. He was a man of stature, Hogan, whom they openly worshipped; the glumness of their mood was therefore in pre-requiem. Then Mary asked the question she had for a whole night been afraid to ask.

"What's it going to be, Dan?"

And he said to her simply, "There'll be no guns."

She fell against him, weeping, clinging to him. He wondered were her tears being shed in gratitude or shame. Women were damned strange, vote or no vote—east or west, or anywhere. He didn't speak to her of what he had in mind, except to say:

"We won't be crawling in the dirt."

HOGAN drove the buckboard into town at half past three in the afternoon. The team of blacks walked slowly, almost with exaggerated courtesy along the one big street of the town. They *clomped* the dry dust to the level of their flanks. Their handsome heads bobbed almost imperceptibly. The sky was the blue of faded jeans. There were puffy clouds no bigger than the beards of ancient men.

The stage was waiting.

"Ya got passengers, Dave!" somebody called.

It was no pleasure to the people of the town to see the baggage on the buckboard. There were few derisive calls. There were no hoots of vicious comedy. Hyman Ranse was waiting on the crude veranda of The Cattleman's Rest. He smoked a thin cigar and looked quite satisfied. The exposed part of his holstered .44 gleamed brightly. When he moved down off the porch into the sunlight you could see the silver of it spring to life like diamonds. He was a relaxed man—steady, sure.

Hogan stepped down to the dust of the wide street, giving his attention to the team. He led them into shade. He made it clear that Mary and the child should not get down. He walked slowly up to Hyman Ranse.

"I'll buy you a drink," he said.

The other man shrugged. "What have I got to lose? It's your money, Hogan. And we've got till four o'clock."

Half the town trailed after them into the huge saloon. Three or four of Hyman Ranse's men clung near. They wore a look of authority, as spanking new as their boss's victory over Hogan, as heady as the rich man's new prestige. The big clock over the bar declared the time: twenty minutes to four.

Ranse raised his glass. "Here's to you, Hogan. That stage gets mighty bumpy."

"That so?"

"After thirty or forty miles of it, you'll need more starch in your spine than you've got ordinarily."

One of Ranse's men laughed cacklingly. Otherwise there was no sound. Too many people were embarrassed by the spectacle of Hogan's shame. The minute hand of the big clock was not

synchronized for gradual travel around the dial. It jerked ahead, as some clocks do, one digit at a time, with awesome sixty second waits between. It was suddenly thirteen minutes to four when Hogan said to Hyman Ranse:

"What makes you so sure I'll be taking the stage?"

George, the bartender, said later on that you could have heard a cow fall through the skylight. Ranse's pleased expression turned to grimness. His eyes went swiftly, uncontrollably, to Hogan's waist. Dan patted the right rear pocket of his jeans.

"I'm naked," he said.

He walked away, his broad back insolent. The crowd fell back, permitting easy passage. Hyman Ranse walked after him with measured steps, the rise and fall of his high-heeled boots a rhythmic, deadly thing. In the open doorway, Hogan paused. He leaned on the rough-hewn sill, his strong fingers ripping bits of bark away. Outside now, already, in the wide street, word was being passed excitedly that Hogan's back was high. He might not take that stagecoach, after all. The faces of a hundred people found his own. There were women there and children, tight-lipped, whispering, watching him. There were older men whose eyes had seen more war and blood than it was good to remember. Hendricksen, who kept a glacier shop, a mild man and a friend, spoke up.

"Don't be a damned fool, Dan. Your luggage is on the racks already. You've got seven minutes, Dan."

"It's nice of you all to think of me," Hogan said.

The glare of the sun had gone from the street. The roofs of buildings opposite were catching the waning glow. A bird, as fat as a chicken, flushed to flight from the eaves of the new post office. But even at this distance, you could hear the forward-thrusting of the clock.

"Six minutes, Dan."

*I wonder, Hogan was thinking, is it an unlawful or an indecent thing for a man to use his brains?* He smiled, and those who watched him, couldn't know the reason why. He never turned to look at Hyman Ranse. *Let him wait and sweat until his nerves are screaming,* Hogan had resolved. As "The Tinsmith," Heaven reward that proud, brave fighter with his fists, had waited naked in the cold, *let Ranse wait now in heat and tumult.*

Dan Hogan walked slowly back to the bar and Ranse came with him every step. The bartender's eyes were on the clock. His apron, in all its history, was never as white as his face.

"You're asking for it, Dan," George said. "He told you, didn't he, for God's sake, that he'd shoot you, armed or unarmed? You can't say that you haven't had fair warning, Dan."

*Three minutes.*

Men began to back away from the bar with nervous care. The semi-circle of

cleared space widened rapidly. The sweat ran down from under Ranse's hat, but he was ready. George, the bartender, laid a revolver on the bar.

"It's better than nothing, Dan." George's voice was queer and cracked. His nerves were springing like old piano wires. "Don't let him shoot you like a rattler, Dan."

Hogan didn't answer him. It seemed to make small difference now. The minute hand sprang forward on the clock. Two minutes left. The agony grew like yeast. Hyman Ranse, his purpose clear, his resolve unshaken, moved a pace or two at the bar. Dan Hogan, rather strangely, moved along with him, leaving George's .44 beyond his reach. Ranse spoke.

"I'll say one thing, and it's the last thing I will say—if you run, you can catch that stage!"

Hogan laughed at him now and Ranse's mouth came open. He licked his dry lips nervously. His eyes were quick, suspicious. He then stepped back another pace. Hogan again stayed with him.

"Give me room!" Ranse screamed. "Give me room!"

"The Lord is my Shepherd," Hogan said strangely. "Don't profane His name now, Ranse." Hogan's voice had a kind of murderous sweetness.

The hand of the clock sprang forward for the next-to-the-last time. The seconds tolled in each man's mind. The sweat poured down like rain on Ranse's face. Dan took the next long, anxious step with him.

"I'm with you, Ranse," he calmly announced, "and at four o'clock, if you don't draw your gun, I'm going to spit in your face."

NOW it was clear. It was so deadly clear. A fighter's hands against a gunman's hand. There was not a yard of space between them. The equation wasn't hard to understand: this far to reach for a gun at your side—that far to punch at another man's jaw. Yet when the action came, it was hard to see. The .44 exploded and the cordite smell was in the air. It clung, like the breath of lilies, but the scene was lacking a corpse. Hyman Ranse was only unconscious, his jaw lop-sided where he lay. Most people said they hadn't seen the punch at all, and that maybe folks did things a little differently back east. The gunsmoke continued to rise like incense. There was a hole in the barroom floor.

Hogan sighed. He let his breath run free. He stooped and picked up Hyman Ranse's very handsome .44. The gunman's friends were watching him, but they stood mutely by. Dan Hogan who, as he had several times confessed in private, could not hit a cow at twenty yards, spoke quietly.

"Who wants to try me, gentlemen? Who wants to—"

Hogan got no further. George had come now from behind the bar and wrapped his arms around him, not in a



gesture of protection, but in a kind of exultation.

"I never," George began to bellow; "no, I never, as the Lord's my witness, ever seen—" and he began to laugh.

Others joined him in their madhouse merriment, though Hogan could not quite see the joke in a situation that had almost been his last. One of Ranse's men bent down and hooked a rough hand un-

## Rod and Gun

(Continued from page 16)

der the boss's armpit. Another fellow assisted. They dragged their fallen champion out the door.

Hogan dropped the shining Colt. He walked out through the vast crowd to the sunlight. He could see his wife in her bright dress running to him. The smell of the sweet grass rode the gentle wind. He had a feeling that he would live a long time in the west.

out of Newark, Jersey City and Hoboken comb the little woodlots in battle array, a comparatively few hunters score regularly each season while the other ninety-nine per cent never kill a deer. The successful ones are the patient hunters, and more: they know deer, and they know where they run and where they turn when alarmed. Also, they know how to shoot.

Even in the close-hunting conditions of Eastern woods, the latter is important. A couple of years ago I went hunting with a man in New Hampshire who started out by showing me his deer rifle. He was rightfully proud of it. It was a beautifully-finished .30-06, a gun capable of dropping a deer at any reasonable distance—or of killing a Kodiak bear, for that matter. Then the hunter pulled a shell box out of his coat pocket and showed it to me.

"I bought this box of shells when I bought that gun five seasons ago," he said disgustedly, "and look at it! I've had only five shots in five years—and three of those were at a porcupine!"

The soft noses of the next five cartridges in the well-worn box were dented where they had been in and out of the gun dozens of times. Needless to say, this hunter had never killed a deer, and I'll wager never will. A good gun alone can't kill game. The first thing he should have done when he bought a new rifle was to sight it in, using at least a box of shells to do it properly; and then he should have poured two or three more boxes through it just to become familiar with its hang and aim. Then, when he got a fair chance at a deer, which he has had twice with his new gun, he could hit it. As a matter of fact, although he is good company, I never hunted deer with him again. Anyone who is that unfamiliar with his gun is a dangerous person to be around.

Of course there are several varieties of dangerous hunters. Another is the kind who gets too excited. I sympathize with this type more than the one unfamiliar with his weapon. If a man didn't get a little bit excited when he tries to get the sights on a big buck, there would be something wrong with him. He might as well have stayed home. However, there is such a thing as overdoing it and mistaking some good farmer's gray mare for a ten-point buck.

Another hunter I don't care to be

around is the one who told me last fall the reason he likes to hunt in New Hampshire or Maine, where it is legal to shoot either doe or buck. "The only way to hunt whitetails," he said, "is to jump them and shoot tails. That's sport. Of course, sometimes you get a small one, and you may wound one occasionally that you don't get, but it's the only real way to hunt deer. It's fast shooting, believe me, and you never know what you'll get."

This man happens to be a deadly shot, and I don't think he could make a mistake, but, again, some joker just might whip out a white handkerchief to blow his nose and catch a .30-30 slug between the eyes. He's right: you never know what you'll get shooting tails.

**P**ERSONALLY, I have just the opposite approach to rifle shooting. I like fast shooting with a shotgun, and I am a better shot when I depend on reflexes rather than deliberate aim. I've never potted a game bird—except for one turkey gobbler, which I still regret—and I have deliberately flushed many sitting birds which I have subsequently missed on the wing, but I would far rather miss a tough shot than pot a game bird. However, with a deer I feel just the opposite. I'll pass up a difficult running shot with the hope of getting one standing. And I'll sit down or take a rest for the rifle before squeezing the trigger. With big game I have but one idea and that is to make a clean kill. I use a five-power scope, even in Eastern whitetail hunting. A scope almost forces a hunter to pick out a spot on a deer and not just shoot at the animal in general. A paunched deer can travel for miles and live hours. Without excellent tracking conditions, he'll likely be lost; and, even if eventually run down, won't be nearly as good eating as one killed outright.

However, I can't say that I get as many chances to prove my preaching as some other hunters might. I am learning, but I am admittedly not a good whitetail hunter, and for two reasons. For one, I am a restless hunter; and, for the other, I like to hunt alone. The latter is difficult, but not impossible. It's not that I am afraid of other hunters—the chances of getting killed are far greater in crossing a city street than in a deer woods—but it does give me a creepy feeling to see a high-powered rifle pointed at my mid-section. The real reason, however, is that I like to



**Checker**<sup>®</sup>  
**NO. 50**  
**WARDROBE RACK**

In churches, schools, clubs, hotels, restaurants—wherever groups gather—Checker-50 Wardrobe Racks answer the wraps problem. Only 5 ft. long, each provides for 50 coats and hats. Available on large rubber casters—they go where needed. Light, strong rigid welded steel for lifetime service. Sold by leading suppliers of institutional equipment and furniture.



**Checker**<sup>®</sup>  
Commercial, industrial and institutional wardrobe equipment and complete checkrooms.

**VALET RACKS**<sup>®</sup>  
Stationary and portable Wardrobe and Locker Racks for the office and the home

Write for Catalog CK-3

**VOGEL-PETERSON CO.**  
1121 WEST 37th STREET • CHICAGO 9, U.S.A.

**Exclusive tailoring process**  
CONVERTS OUTDATED  
**DOUBLE BREASTED SUITS**  
INTO SMART NEW  
**SINGLE BREASTED MODELS**

Write Dept F for FREE BROCHURE and detailed information on how we can perform this AMAZING TAILORING MIRACLE  
Copyright 1954 BY Sid Colburn

**Sid Colburn**  
313 NO. BEVERLY DRIVE  
BEVERLY HILLS, CALIF.

**OWN a Business**

If employed, start part time. Alert dealers can gross \$5 hourly profit plus \$3 on EACH serviceman. Clean, revive, mothproof rugs & upholstery on location. No shop needed. We locally train and assist you. Nationally advertised world-wide service. Quickly established. Easy terms. Send today for FREE booklet. No obligation.

**Duraclean Co., 4-54D Duraclean Bldg., Deerfield, Ill.**

**Give GREAT NEW DRIVING EASE**

**HULL AUTO COMPASS**—handsome, scientific instrument—is an ideal Christmas gift. Comforting, sure-way motoring guide the year 'round. Hull is the only auto compass, as a stock item, approved and used on combat vehicles in World War II.

Write for local dealer's name, free literature.

**BEACON LIGHT \$6.95**  
**STREAMLINE \$4.95**  
NON-ILLUMINATED

**MORE HULLS IN USE THAN ALL OTHERS COMBINED**

**HULL MFG. CO.** P. O. Box 246, EE-11  
WARREN, OHIO

**GENUINE**  
**BRONZE TABLETS**  
**FOR LESS!**

Our vast plant devoted exclusively to bronze tablet work gives you unsurpassed quality at lowest prices.

Fast mail service—Free sketches

Write for big **FREE** illustrated Catalog

Honor Rolls — Awards  
Testimonials — Memorials  
"Bronze Tablet Headquarters"

United States Bronze Sign Co., Inc., 570 Broadway, Dept. E, New York 12, N.Y.



hunt. I want to hunt my own deer, and I don't particularly care to shoot one that just happened to run into me in a confused effort to escape from other hunters.

Hunting alone means work because it necessitates getting back off the road, beyond the others. Where I hunt, and it has proved successful, is the high ridges. Few hunters will put themselves out to the extent necessary to go up there, but the deer will. Big bucks seem to work high in the fall. Likely this is because they are driven out of the valleys by hunting pressure—so actually I am being aided by other hunters at that—although possibly it is just their nature to go to the ridges. The big disadvantage; of course, is the work involved in getting a deer out after he is shot, but I figure it is time to worry about that after I get one. There's this about it: it's always downhill from a high ridge.

But, being a restless hunter does not have any advantage that I have discovered. Last fall I jumped a couple of big deer on a high ridge and separated them. This is an ideal situation for a lone hunter. The chances are that two large deer lying up together on a ridge are buck and doe. If separated, eventually the buck will back-track, nose to the ground like an old blue-tick hound, pick up the trail of the doe and rejoin her. I knew this and sat down, making myself as comfortable as possible. It was a mild day, so it should have been pleasant to sit it out; however, I got impatient and had to get up to take a look around. I no more than started out when the buck jumped less than a hundred yards from me. I watched his tail flop from side to side as he bounded off through the woods, but I couldn't see what kind of a rack he had. He had obviously been on his back-track, and in another two minutes or three

would have walked right up to me—if I had sat still.

I finally settled for a five-pointer on another ridge, although I had wanted to get a big head. It was a good stand where I got him, with plenty of fresh sign including some very large tracks. The temptation had been to follow the big tracks, but I remembered what Harry Leonard had said and sat down. Fortunately my wool coat was covered with beggar's lice, and I told myself I would sit right there until I had picked off every last one of the burs. I had just about completed the tedious job when I glanced up and my buck was standing in the clear an easy shot away.

WHEN I was dragging him down the mountain after dressing him, I left him for a moment to walk to the point of a knoll and survey the best way out. As I did, a big doe stepped out into the clear just under the knoll. I watched behind her where she had come from and, sure enough, a huge buck stepped out behind her. This was the deer I had been day-dreaming about. It was one of Harry Leonard's mounted deer heads in the flesh, and he stood broadside to me not thirty yards away watching the doe. I looked at him through the scope of my rifle and could count the hairs on his neck. I had shot my buck a half-hour too soon, but no matter. I knew someone I would bring back the next morning to get a shot at him, and there was no reason why it couldn't be done.

When I drove my car across a farmer friend's pasture to pick up my deer at the base of the hill, I stopped and told him about the big one I had seen. This farmer wasn't a hunter, so there was no harm in telling him about it. I was so excited I had to talk to someone, and

even if he did mention it to a neighbor, no one ever bothered the high ridges anyway.

The next day was Thanksgiving. I got my friend up long before daylight and we started for the ridge. I explained that if we were on top by dawn, the other hunters would commence working up from the edges and surely drive the big buck to us. There had been no indication that any other hunter had been up there on top all season, and I knew that none would go up there; it was too much of a climb. My partner's legs began to give out half-way up the mountain, but I kept prodding and talking about the size of the buck until we finally made the top. My own legs felt like damp spaghetti from the long pull, but we had arrived on time. It was just beginning to break day when we reached the stand.

"Well, this is it," I said, taking a deep breath. "All we have to do now is wait."

"This is where you saw the big fellow, is it?" a strange voice asked out of the semi-darkness. "They tell me he's a good un."

I commenced looking around, and the whole town was up on that ridge. There was a hunter behind every tree, and two behind the big ones. The old buck would be somewhere over the next mountain by now.

My friend is a good sport, and likes to hunt, but on occasions is somewhat lacking in a sense of humor. "You and your big mouth," was the only remark, and we turned and dragged ourselves back down the mountain in silence.

The trouble with Eastern deer hunting is that a man not only has to understand deer, he has to understand deer hunters as well. I still have a lot to learn.

## Colonialism Passes

*(Continued from page 11)*

is to maintain its championship of freedom.

This opposition to "colonialism" is not some startling new phenomenon. After all, our Thirteen Colonies put up some sturdy resistance to the idea of alien government about 175 years ago and changed the face of a continent. In more recent times there has been an increased sensitivity to the feeling that there was something fundamentally wrong with the principle of the rule over one group of peoples by an alien group that was imposed without the consent of those who were ruled. This was the basis for Woodrow Wilson's great crusade for "self-determination" that changed the map of Europe. It made possible the mandate system under the League of Nations. It is alive today in the trusteeship system of the United Nations. "Colonialism", as such, is in complete disrepute, and deservedly so.

What's wrong with it, as an idea? It brought to subject peoples a higher

standard of living, better health and sanitation, a great development of natural resources, an era of peace and order. The story is not just one of black and white. There were good things in the colonial regimes as well as bad. But we are committed, as in the Pacific Charter, to put an end to such regimes as soon as we can and wherever we can. Why?

The indictments of colonialism are usually based on the emotional appeal of "loaded" words such as "slavery" or "freedom". There is, however, a strong indictment that can be based on the hard facts of economic life. The colonial system tended to develop an economic pattern in which the people who made the profit possible didn't get enough of it themselves. This pattern is what is called the "colonial economy."

It centers around the production, in non-industrial areas, of raw materials that are processed and marketed in remote industrialized areas. This presents two serious defects. First, it is in the

economic interest of the processor—in this case representing the colonial power—to keep down raw material costs so as to enlarge the margin of profit. The first of those costs is that of labor and the colonial economy has both taken advantage of cheap labor and has tended to keep it cheap. In many instances, similarly, there has been actual resistance to the introduction of labor-saving machinery, since it was cheaper to rely on a large supply of underpaid manpower. Thus, while new sources of wealth have been developed they have not been transplanted into what should have been a more rapid rise in standards of living.

Second, this production for a remote market has tended to concentrate upon a relatively few products with a consequent serious unbalancing of production as a whole. Diversity of crops has disappeared in some cases and people have gone hungry because they were raising something that could not be eaten and raising it for a foreign market. This, in



turn, may make the actual life or death of a people dependent on the fluctuations of a money market thousands of miles away over which they have had not one iota of control.

It is for this reason that in recent years the idea of patriotic nationalism has usually been coupled in the colonial areas with the demand for increased industrialization so that raw materials could be processed and used at home. Those who have been "colonial minded" have too often resisted this demand and introduced only such industries as involved the first steps in processing and not the production of finished goods. But here again there has been the tendency to take advantage of cheap labor, in this case industrial, and to keep it cheap.

Furthermore, the introduction of such industries has not provided a sufficient field for labor so as to take pressure off the land. Indeed, the very advances in public health that the colonial system has brought about have often increased the pressure. Death rates have gone down, birth rates have gone up. There has been a tremendous population increase in almost all the colonial areas in the past half century. There are more and more mouths to feed and the means to feed them adequately have not kept pace. There has been improvement, it is true, but it has been woefully slow and the result has been inadequate.

When we speak of "colonial-mindedness" we come up against another big thing that has been wrong with the colonial system. It has always developed its own peculiar inertia. It has until recently been resistant to change. The motto of the colonialists has too often seemed to be: "Make sure that it is too little and too late." This attitude accounted for a part of the tragedy in the strife between the Dutch and the Indonesians and for an even larger part of the French debacle in Indo-China.

As in the economic field, so in the political, the colonial system clashes with honest nationalism. And this is the biggest reason that we are determined to rid ourselves of the incubus of this system.

We have set forth in our own Constitution that we hold that governments derive their just powers from the consent of the governed. Conversely, then, a government that does not have that consent is exercising its powers unjustly. The rise of nationalism is founded upon the demand for self-government. That means, automatically, the withdrawal of alien rule, since the very demand for self-government implies the withdrawal of consent to such rule.

It is not enough to answer that self-government does not necessarily mean good government. Often it does not and some of the countries that have recently achieved independence are not as well governed as they were under a colonial regime. That does not alter, however, the validity of the principle that just powers

derive from consent. Manuel Quezon, a great Philippine nationalist, put this distinction in a nutshell when he said: "I would rather live under a government run like hell by Filipinos than under one run like heaven by Americans."

The case against "colonialism" is a strong and a valid one. Obviously, if we are to live up to our own code of morals, we will have to sustain the principle that when consent is withdrawn the colonial system must be changed. Most of the free world has now come to that way of thinking. What, then, is it doing to translate its thought into action? What more should it do?

The first general movement to promote the independence of subject people took form immediately after World War I. The occasion was the disposal of the possessions of the German and Turkish empires. To handle this a "mandate" system was set up under the League of Nations and several areas were put under the control of other powers that were pledged to work for their advance toward self-government. They were called upon to report their progress to the League. Similar machinery has been set up under the United Nations in its "trusteeship" system, both to handle the former Japanese mandates and other underdeveloped areas that are not yet ready and able to assume the responsibility of self-government.

The Japanese abused the mandate system, turned the Pacific Islands into naval and air bases and refused to report to the League of Nations or to permit inspection. Britain and France, on the other hand, with the important mandates in the Near East, complied fully with the spirit and the letter of the mandate system. As a result there have emerged in this area, in this generation, five new independent nations. They are Syria, Lebanon, Iraq, Jordan and Israel. From the trusteeship system one newly independent country has already been established, Libya, in North Africa.

SOME of the "trust territories," such as the Marshall and Caroline Islands, which are a United States responsibility, or the Cameroons and Tanganyika, which are French and British responsibilities, respectively, are obviously not yet ready for full self-government and could not sustain it if it were granted. But the goal had been proclaimed and the direction set. The movement is toward self-government, not away from it.

Parallel to the mandate-trusteeship system in our time, but much older in its inception and growth, has been the development of the "Commonwealth" idea in respect to the British "Dominions Over the Seas." Beginning with Canada and extending subsequently to Australia, New Zealand and South Africa the Commonwealth was formed. Under it, the member states gave their voluntary allegiance to the British Crown—government by full consent—but obtained and

not everyone does as well, but E. O. Lockin, who started a business of his own, reports...

**for 12 months I've averaged**  
**\$800 PER MONTH**  
**INCOME—**  
**most of it clear profit for me!**

Many men have discovered how to be independent, to be free of bosses and layoffs. L. A. Eagles grossed more than \$200 his first week. Others report gross up to \$12,000 per year. How much you make depends largely on you. You need no special skill, no large investment.

**No shop necessary.** Our ELECTRIC RUG WASHER cleans rugs, carpets right on floor... helps to show their natural color and beauty. So efficient and safe, used by largest hotels and railroads.

You take no risk. Machines fully guaranteed.

Write for full information including how to make big profits in YOUR OWN business.



**MAIL COUPON TODAY FOR FREE BOOK**

• Von Schrader Mfg. Co., W24 "R" Pl, Racine, Wis. •  
 • Without obligation, send your FREE booklet containing information about your ELECTRIC RUG WASHER and how I can start my own permanent, profitable business. •  
 • Name \_\_\_\_\_ •  
 • Address \_\_\_\_\_ •  
 • City \_\_\_\_\_ Zone \_\_\_\_\_ State \_\_\_\_\_ •

**BE YOUR OWN BOSS**

If you have \$3,000 to \$3,500 and would like to be in business for yourself, write, wire or call Tastee Freez. OVER 1100 SUCCESSFUL STORES now in operation EARNINGS LARGE.

**tastee-freez**

SOFT ICE MILK  
SOFT ICE CREAM

Tastee-Freez is a Reg. Trademark  
**TASTEE-FREEZ CORP. OF AMERICA**  
 2518 W. Montrose, Dept. L, Chicago 18, Ill

**MAGIC IS FUN! MAKE MAGIC YOUR HOBBY**

**CHANGE NICKELS INTO DIMES!**

place MAGIC CAP over 4 nickels. Presto! Nickels vanish and 4 dimes appear! Cap may be examined. No skill required! Precision-made device. ONLY \$1.00 POSTPAID. Remit money order or cash. Satisfaction Guaranteed.

• FREE! WITH YOUR ORDER •  
 LARGE CATALOG of 500 Amusing and Professional Magic Tricks. WRITE TODAY!  
 D. ROBBINS & CO., Dept. D-293  
 127 W. 17 St. New York 11, N. Y.

**GENUINE HARGO HIDE JACKET \$9.98**

Reduced to \$8

This genuine Hargo Hide Jacket is stronger than most leathers and will take rugged and long wear. Save dollars on this value. Heavy fleece lining, raglan sleeves, knitted bottom and cuffs, zipper front and breast pocket, 2 slash pockets, water repellent treated. Sizes S, M, L, XL. (In Brown only.)

Boys sizes 10-18 only \$7.98

Send no money, pay postman plus 95c COD or send Money Order for total and we pay postage. 10 Day money back guarantee. Exchangeable after Xmas.

**STRAGO MFG. CO.**  
 Dept. G-8, 211-7th Ave., N. Y.

**60 POWER TELESCOPE \$3.98**

VARIABLE EYEPIECE 20X-40X-60X—BRASS BOUND

**NEW!** Three telescopes in one. 3 different magnifications. 20 power for ultra-bright images with 40 and 60 power for extra long range. Guaranteed to bring distant objects, people, sports events, ships, moon, stars, etc. 60 times as close.

Most powerful for anywhere near the money. 3 Sections. Closes to 1 ft. long. Contains 4 ground and polished lenses. Also used as a powerful compound microscope. Directions included. Mass production enables us to offer this instrument at amazing price of \$3.98 complete. MONEY BACK GUARANTEE. We pay postage. Get yours now.

**CRITERION CO., 331 Church St., Hartford, Conn., Dept. EMB17**



retained full self-government. The last vestige of British rule in the Commonwealth was removed by the Statute of Westminster of 1931 in which it was decreed that acts of the British Parliament had no validity in the Commonwealth states.

In the past seven years the concept of the Commonwealth has changed still further. It now has one member that does not give allegiance to the British Crown, India. The Indians have set up a republic and recognize the Crown merely as the symbol of the Commonwealth association, from which they can retire if they wish. Pakistan and Ceylon, which have also become independent since World War II, have retained the formality of the former Commonwealth, but may later follow the Indian pattern. They are free to do so. There is also some agitation for a republic in South Africa.

ONE OF the great former components of the British Empire, Burma, has chosen not to remain in the Commonwealth pattern and its complete independence was recognized by the United Kingdom in 1948.

Both the French and the Dutch have tried to establish a modified form of the Commonwealth system but with less success. The French idea was that of the "French Union," in which a high degree of self-government would be achieved but the ties to France retained. This was not defined with sufficient clarity in the case of the three Associated States of Indo-China—Vietnam, Cambodia and Laos—and a large body of nationalist opinion was alienated from France. As the result, the French Union faced a military campaign against the Communists that could not be won. France has now recognized the complete independence of the three states in Indo-China and their relation to the French Union will be settled, ultimately, by negotiation, provided they can be kept out of the hands of the Communists.

In the case of the Dutch there has been one conspicuous failure and one outstanding success. What was originally planned was a new Kingdom of the Netherlands, with three co-equal parts, Holland itself, Indonesia, and the Dutch possessions in the Caribbean, Surinam and the Netherland Antilles (Curacao and Aruba). This did not satisfy the Indonesian nationalists and in 1949 the Netherlands agreed to a grant of complete independence. They preserved, however, what was agreed upon as the "Netherland-Indonesian Union" in which close economic and cultural ties were to be preserved. This Union has now been denounced by the Indonesians and has come to an end. In Surinam and the Antilles, on the other hand, the direction has been opposite. In them, a new constitutional pattern has been evolved under which they have become fully self-governing but are proud to be "co-equal partners" under the Crown. No less than

## Presentation to GRAND EXALTED RULER

Grand Exalted Ruler William J. Jernick receives an electronic traveling secretary—the Edison Voice-writer—as he prepares to take a year's leave of absence as production manager of the primary battery division of Thomas A. Edison, Inc. Making the presentation is George E. Stringfellow, Vice-President of the company and general manager of the Voicewriter Division.



the Indonesians they now have a government empowered by their full consent.

The United States followed the Commonwealth pattern only briefly in its grant of independence to the Philippines. A Commonwealth was established in 1935 under which the Filipinos enjoyed complete local self-government but retained American sovereignty. This, however, was designed and designated merely as a transition period and was limited to ten years, after which the Philippines were to be completely independent. This pledge on the part of the United States was carried out to the letter after the archipelago was liberated from the Japanese. The Philippines thus became the first democratic republic in East Asia to have come out of the former colonial pattern.

That this has reacted enormously to the advantage of the United States goes without saying. In the campaigns of 1941 and 1942 the Filipinos fought beside us as blood brothers. The anti-Japanese guerrilla movement in the islands was the biggest Fifth Column in history and it made the liberation possible with far fewer American casualties than could have been imagined. But more than that, the eloquent Filipinos are now our champions and our spokesmen, as they have been recently in the United Nations. And they are saying to fellow-Asians: "This talk of freedom is not hollow; we ourselves have been set free."

In addition to the grants of independence there have been in recent times various modifications of colonial sovereignty in the direction of far wider grants of self-government. We have already mentioned the case of Surinam. The United States took a similar action in the case of Puerto Rico where the Puerto Ricans themselves were authorized to choose the form of government

they wished and to determine their relationship to the United States by their own consent. They retain American Sovereignty but have full self-government.

Great Britain has established local self-government in the Gold Coast, in Africa, and has developed a new self-governing Central African state made up of Northern and Southern Rhodesia and Uganda. France has just offered complete self-government to Tunisia and is working for an agreement in this field with Morocco.

THE MOROCCAN CASE, however, is illustrative of the fact that while we have come a long way there is still some substantial way to go. France has had two types of administration in North Africa. In Algiers the problem of "colonialism" does not arise. Algiers is part of Metropolitan France, electing its own members to the Chamber of Deputies. It is no more a "colony" than Hawaii and Alaska are "colonies" of the United States. Tunisia and Morocco, on the other hand, are "protectorates," in which the rule of a local monarch is recognized but in which he is subject to a firm degree of control. There are strong nationalist movements in both protectorates with the demand for at least full local self-government if not outright independence. Some big gains have been made recently in Tunisia and a new charter of self-government is in the making. Morocco is not as far along and the case there is complicated both by the rivalry of two Muslim factions and hostility between urban Arabs and back country Berbers.

The French problem here is again one of timing. It is widely agreed that France could have saved much of the loss in Indo-China if there had been more imagination and more flexibility earlier



in the clash. France has granted, in 1954, an independence to the Indo-Chinese states that would have been more effective in heading off Communist inroads had it been granted, and made really symbolic, seven years earlier. Similarly, the Dutch allowed the nationalists in Indonesia to put them in the position of resisting true freedom by bad timing and by a diehard faction in the Dutch Parliament that threatened the fall of any government that made concessions. Good intentions are not enough, as the British discovered in India. There must be the willingness to take chances and to make changes, sometimes swiftly.

**A**CTUALLY, however, aside from the trusteeships under the United Nations where self-government is out of the question, there are only two "colonial" areas left in East Asia. The French grant of independence to Free Vietnam, Cambodia and Laos has taken Indo-China out of the picture. It was a big colonial problem and the French have solved it in the only way in which it could be solved, by making the "Associated States" independent. Malaya and New Guinea remain.

In Malaya, a British protectorate (Singapore is a Crown Colony), Britain has been bedeviled not so much by the Communist terrorist movement as by the facts of life. The Communists could not set up a government for Malaya if the British got out tomorrow. The problem is one of plural population. The people of Malaya are about equally divided between Malays and Chinese. The two groups have not yet been able to get together. On top of that is a small group of resident Indians who are politically self-conscious and who can sometimes hold the balance of power. Britain has worked out a new "Malayan citizenship" for the Peninsula and has offered two different constitutions but they have not yet been accepted by the local political parties. Political progress is being made—along with the suppression of Communist terrorism—but Malaya cannot yet take over the Commonwealth status that will eventually be assumed.

The case of New Guinea is quite different. At present western New Guinea is governed by the Netherlands, Eastern New Guinea by Australia. Indonesia demands that western New Guinea be turned over to Indonesian rule and has brought the case before the United Nations. The Dutch, backed by the Australians, are opposed to this change. The issue of "colonialism" can hardly be involved. The native inhabitants of New Guinea, not more than one per cent literate, certainly have not been consulted. The literate ones have indicated that they prefer a colonial status under the Dutch to a colonial status under the Javanese Indonesians. There is no possibility of "self-determination" and no possibility of independence. The best that can be hoped for is a benevolent

rule for some time to come. The Dutch think, and the Australians agree with them, that they will be more benevolent than the Javanese.

The other large remaining colonial area is Africa. Changes are being made on the map there and more will be made. We have already mentioned France's problems in the north. The same situation does not exist in West Africa or in Equatorial Africa at this time. That does not mean that it will not arise later. Similarly, the Belgian Congo, the large Portuguese holding of Angola on the west and the smaller Portuguese colony on the east are politically quiet.

Two things, however, are happening. On the one hand, Britain has encouraged great political progress with the grant of local self-government in the Gold Coast, the effort to take similar steps in Nigeria, and the establishment of what will be a central African Commonwealth. On the other hand, the South African Government of Premier Malan has dedicated itself to a gospel of race segregation and "white supremacy" on a continent where the whites are outnumbered about twenty to one. The net effect of "Malanism" must certainly be the encouragement of African nationalism and the eventual end of "white supremacy." There are times when stupidity is self-defeating.

This policy of "racialism" in South Africa has given much ammunition to the Communists in their efforts to becloud the issues as to just what is involved in this "colonialism" question. It is imperative that we, who want to see an end to colonialism, know just what it is and what it is not. There is much confusion on this point.

**J**UST WHAT is "colonialism"? Technically, it is the rule over one group by another and alien group. In most of our thinking, however, it has a wide body of assumptions and implications that go beyond this. Some of these will not bear examination. Margaret Mead, the eminent American student of dependent peoples, put her finger on one of these false assumptions when she remarked: "If you go across an ocean and push people around that's 'imperialism' and 'colonialism'; if you stay on the same continent and push people around that's just 'legitimate expansion'." Colonialism is not just a question of political geography.

Similarly, Communist propaganda never fails to confuse colonialism with racialism whenever this is possible. Many colonies, of course, have represented the rule of whites over pigmented peoples. But there have also been colonies in which whites ruled whites, such as our own original thirteen, and the present colonies of the Soviet Union, such as Latvia, Estonia and Lithuania and, indeed, all the others now euphemistically called "satellites." There are colonies in which the pigmented rule, or have



## SEND FOR YOUR dermassage SAMPLE

**MORE THAN 4000** hospitals throughout the world use it daily! **PROTECTS** against externally caused skin disorders. **RELIEVES** tired, aching muscles and chaffed, itchy dry skin and tired feet. **RELAXES** tense nerves; induces restful sleep. Use for baby's tender skin, too.

**SEND 10c** and this ad for sample 4 ounce dispenser and free booklet on skin care to: EM

**dermassage** 30 W. Washington St. Chicago 2, Illinois

Product of Edison Chemical Company

### PUMP WATER FAST!

Drains Wash Tubs, Cellars, Cisterns. Famous #7 pumps 2800 gph. 420 gph. at 75' high or 1600 gph. from 25' well. Sturdy rustproof alloy metal. Six blade impeller. 3/4" inlet, 1/2" outlet. Standard pipe threaded. Uses any 1/4 to 1/2 H.P. Motor. Will not leak or \$8.95 clog. Iron clad guarantee. Send check, M.O., or sent C.O.D. **\$11.95**

Irrigate, Fill Tanks, Draw Well Water. Heavy duty #8 pumps 7000 gph. 1000 gph. 75' high 3000 gph. from 25' well. Rustproof alloy metal. 8 blade impeller. 1" inlet, 1" outlet. Standard pipe threaded. Will not leak or clog. Iron clad guarantee. Send check, M.O., or sent C.O.D. **\$11.95**

Free Catalogue—Gear Pumps, Large Centrifugal Pumps, Deep and Shallow Well Pumps, Sump Pumps.

**MOORE MANUFACTURING CO.**  
SWEDSBORO 11, NEW JERSEY

### WILD LIFE FILMS

Exciting, dramatic action in the natural habitat of animals of forest and plains. 8mm or 16mm in beautiful color or B & W. Also 2" x 2" color slides. Write for free illustrated catalog.

Wild Life Films 5151 Rm. 1 Strohm Ave., No. Hollywood, Calif.

## RUPTURE-EASER

FOR MEN, WOMEN AND CHILDREN Reg. in U. S. Pat. Off.

A strong, form fitting, washable support. Back lacing adjustable. Snaps up in front. Adjustable leg strap. Soft, flat groin pad. No steel or leather bands. Unexcelled for comfort. Also used as after-operation support. Give measure around the lowest part of the abdomen. Specify right or left side or double. We pay postage except on COD's.

**PIPER BRACE CO.**  
811 Wyandotte Dept. EK-124 Kansas City 5, Mo.

Right or Left Side **\$3.95**  
Double **\$4.95**

## STOP PAIN

of  
**ARTHRITIS,  
RHEUMATISM,  
BURSITIS,  
SPRAINS AND STRAIN**  
apply

# Arth-Rhuma

THE METHYL SALICYLATE BANDAGE. Gives quick relief without rubbing or liniments. This medically approved bandage provides the dual benefits of Oil of Wintergreen with gentle pressure.

Price \$1.25 post paid  
Send check or money order to:  
**MEDICAL BANDAGES INC.,**  
P. O. Box 295 Hackensack, New Jersey  
Satisfaction Guaranteed or Money Refunded.



## EFFECTIVE "ELK HISTORY" PRESENTATIONS

One of the interesting current activities among the subordinate lodges of the Order is the way the "History of the Order of Elks" is being used as a method of acquainting citizens of the lodge's community with the traditions and work of Elkdom. Books have been presented to libraries on several occasions by lodges, and particularly effective is the current work of Naugatuck, Conn., Lodge No. 967. This lodge has given a copy of the History to every church library in Naugatuck, as well as the Public Library, with the understanding that every book will remain permanently in the library to which it was given.

Past Exalted Ruler Riter E. Hughes

personally called on every clergyman and presented the History, and this call was preceded by a letter to the clergymen from Secretary John E. Ash. The lodge had a splendid thought in doing this, because at the Memorial Service in December each year, one of the local clergymen is invited to deliver the eulogy, and the "History of the Order" in his library is a great assistance in preparing his address. As Brother Joseph E. Sommers, who provided us with the information, says: "In my opinion this could be a project for every Elks Lodge, for when you consider it from a public relations viewpoint, it is evident that much good will is gained."

ruled, the pigmented such as Japan's possessions in the past and Red China's present colonies in Tibet and northern Korea and prospective colony in northern Indo-China. But because race prejudice is an explosive thing it can be used to confuse an issue as it does in the case of "colonialism," and as it most certainly does in South Africa.

The real issue is that of external rule, the exercise of sovereignty from without. It is an issue because it presupposes a government that does not exist by virtue of the consent of the governed. When that consent is freely given to any sovereignty, external or internal, "colonialism" does not exist and could not endure. When that consent is not given and cannot be given there is real "colonial" rule. And that is true regardless of whether the colony is the Congo or Rumania, Kenya or East Germany.

**F**ORTUNATELY, the establishment of institutions of free learning in the colonial areas has, in recent years, made it possible to put emphasis on this point. The predominant body of political thought in Great Britain, France, the Netherlands and the United States has been what we call "libertarian." Where education has been possible in the colonial areas, the impact of this great body of thought has laid the foundation for much that is good in nationalism in colonial areas. Thus Indian nationalists were able to quote with telling effect the great speeches of Edmund Burke. The Vietnamese were able to call to the attention of the French the motto of the French Revolution. And there was the case of the Filipino boy who was told by his teacher to answer the question: "What is a cow?" He wrote: "A cow is a big, oblong animal with four legs, one on each corner. A cow gives milk, but as for me, give me liberty or give me death!"

In the last quarter of a century, indeed, the best thing about the colonial regimes of Britain, the Netherlands, France and the United States, was that

they offered the opportunity for political progress. The goal, in each case, was more rather than less self-government. "Enlightened" colonialism must in the long run lay the foundation for the end of colonial rule. That has already happened in a large part of the once colonial world. The process is still going on and is being accelerated.

Meanwhile, a fuller understanding of this basic question of government by consent of the governed is imperative if we are to meet and offset the insidious and skillful propaganda of the Communists. They have played the issue of "colonialism" for all it is worth and they have made it worth quite a lot to their own cause.

In the first place, in accordance with the instructions of Lenin, they have been able to capture some honest nationalist movements. This is what they did in Indo-China where Ho Chi Minh, a Kremlin agent for more than a quarter of a century, was able to capitalize on antagonism to the French to recruit a large following that had no knowledge of or interest in any Marxist revolution. The argument was simple. "Colonialism" is wrong. We, that is, the Communists, are opposed to "colonialism." Therefore, we, the Communists, must be right. And the argument worked. What is more, Ho Chi Minh carefully denied that he was a Communist until he was firmly in control of the revolutionary movement.

Equally dangerous is the power that this idea of "colonialism" has to immobilize clear thinking in some other gravely threatened areas. In India, for example, Prime Minister Nehru and his followers are so busy flogging the dead horse of "colonialism" that they cannot see the live tiger of world Communist conspiracy. The memories are dying hard.

The case of Indonesia is similar and worse. Any move by the Western powers, such as military assistance or the signing of the Manila Pact, is automatically suspect. It is "neo-imperialism." But in the meantime the Communists have

moved in and have installed their agents in the Ministries of Defense and Education, have taken control of key posts in the army, and permitted a "coalition" government to survive only by their consent. This is set forth, of course, as "neutralism" and anti-colonialism. And the crowning touch is the drive in both India and Indonesia to conclude "non-aggression" pacts with a proclaimed aggressor, Red China!

Indeed, the supreme irony of this whole situation is that the Communists have succeeded in pinning the label of "colonialist" on the nations of the free world that are committed to getting rid of colonialism. It is ironic because precisely during the time that more than twenty nations have attained government by full consent in the "colonialist" world, nineteen have lost their freedom of consent through conquest by the Soviet Union and the world Communist conspiracy. If consent of the governed is to be the standard, and we think it must be, it may be a good thing to "look at the record."

It is a grim record of making Communist colonies out of what were once free nations. In not one has a free election ever been permitted. This is not a "Commonwealth" made up through the association of like-minded states. It is a Soviet Empire, ruled from Moscow. Here is the record of annexations to that empire in thirty years: Tannu Tuva, Outer Mongolia, Estonia, Latvia, Lithuania, Albania, Hungary, Rumania, Bulgaria, Karelia, East Prussia, Poland, Czechoslovakia, East Germany, China, North Korea, Tibet, and now, North Vietnam. This is the real "colonialism" that is rampant in the world today. It is predatory and it is ruthless.

**S**ET AGAINST THAT the other record: Independence for the Philippines, for India, Pakistan, Burma, Ceylon, Indonesia, Free Vietnam, Cambodia, Laos, South Korea, Syria, Lebanon, Jordan, Iraq, Israel and Libya. New self-government for Surinam, Netherlands Antilles, Puerto Rico, the Gold Coast, Rhodesia and Uganda, Eritrea and Tunisia. Put against it also the whole system of trusteeships around which there is no Iron Curtain.

We have had, and still have, a bad conscience about "colonialism." This is all to the good when it spurs us to further efforts on behalf of government by consent. Those efforts must be continued. But there is no reason why we have to take the Communist lies lying down.

Our course is clear. We must continue to seek justice and equity. We must right wrongs. We must serve the cause of human freedom. We must meet the hollow mockery of Communist fair words by bold action. We must expose in all its evil falsehood the Communist pretense to the championship of freedom. This is our job. If we are intelligent and imaginative, it can be done.



# 1954-55 Grand Lodge Officers and Committeemen

## GRAND EXALTED RULER

WILLIAM J. JERNICK, Nutley, N. J., Lodge, No. 1290, 674 Bloomfield Ave., Nutley 10.

### GRAND ESTEEMED LEADING KNIGHT

BENJAMIN F. WATSON, Lansing, Mich., Lodge, No. 190, 311 American State Bank Bldg.

### GRAND ESTEEMED LOYAL KNIGHT

SIDNEY W. ROBINSON, Reno, Nev., Lodge, No. 597, Box 11.

### GRAND ESTEEMED LECTURING KNIGHT

JACOB L. SHERMAN, Denver, Colo., Lodge, No. 17, 624 University Bldg.

### TEMPORARY GRAND SECRETARY

LEE A. DONALDSON (Etna, Pa., Lodge, No. 932) Elks National Memorial Headquarters Bldg., 2750 Lake View Ave., Chicago 14, Ill.

### GRAND TREASURER

ROBERT G. PRUITT (Buckhead, Ga., Lodge, No. 1635) 808 Southern Railway Bldg., 99 Spring St., S.W., Atlanta 3, Ga.

### GRAND ESQUIRE

(To be appointed)

### GRAND TILER

OTTO B. STIELOW, Sheboygan, Wis., Lodge, No. 299, 1702 No. Fourth St.

### GRAND INNER GUARD

S. O. MORROW, Flagstaff, Ariz., Lodge, No. 499, 322 West Santa Fe Ave.

### GRAND CHAPLAIN

REV. RICHARD J. CONNELLY (Lancaster, Ohio, Lodge, No. 570) 219 North St., Washington Court House, Ohio

### ACTIVITIES COORDINATOR

BERT A. THOMPSON (Green Bay, Wis., Lodge, No. 259) 2750 Lake View Ave., Chicago 14, Ill.

### SECRETARY TO GRAND EXALTED RULER

MATTHEW J. COYLE, Nutley, N. J., Lodge, No. 1290, 674 Bloomfield Ave.

### BOARD OF GRAND TRUSTEES

FRED L. BOHN, *Chairman and Approving Member*, Zanesville, Ohio, Lodge, No. 114, 50 So. Third Street.  
NICK H. FEDER, *Vice-Chairman and Home Member*, Belleville, Ill., Lodge, No. 481, 126a East Main St.  
ARTHUR M. UMLANDT, *Secretary*, Muscatine, Ia., Lodge, No. 304, Box 17.  
RONALD J. DUNN (Building Applications), Oneida, N. Y., Lodge, No. 767, 324 Madison County Trust Bldg.  
HORACE R. WISELY, Salinas, Calif., Lodge, No. 614, 121 East Gabilan St.

### ADVISORY COMMITTEE

JAMES R. NICHOLSON, *Chairman*, Springfield, Mass., Lodge, No. 61.  
HENRY C. WARNER, *Secretary*, DIXON, Ill., Lodge, No. 779.  
EDWARD RIGTOR, New Orleans, La., Lodge, No. 30.  
BRUCE A. CAMPBELL, East St. Louis, Ill., Lodge, No. 664.  
JAMES G. McFARLAND, Watertown, S. D., Lodge, No. 838.  
WILLIAM H. ATWELL, Dallas, Tex., Lodge, No. 71.  
CHARLES H. GRAKELOW, Philadelphia, Pa., Lodge, No. 2.  
JOHN F. MALLEY, Springfield, Mass., Lodge, No. 61.  
JOHN R. COEN, Sterling, Colo., Lodge, No. 1336.  
FLOYD E. THOMPSON, Moline, Ill., Lodge, No. 556.  
JAMES T. HALLINAN, Queens Borough, N. Y., Lodge, No. 878.  
EDWARD J. McCORMICK, Toledo, Ohio, Lodge, No. 53.  
JOHN S. McCLELLAND, Atlanta, Ga., Lodge, No. 78.  
E. MARK SULLIVAN, Boston, Mass., Lodge, No. 10.  
FRANK J. LONERGAN, Portland, Ore., Lodge, No. 142.  
ROBERT SOUTH BARRETT, Alexandria, Va., Lodge, No. 758.  
WADE H. KEPNER, Wheeling, W. Va., Lodge, No. 28.  
CHARLES E. BROUGHTON, Sheboygan, Wis., Lodge, No. 299.  
L. A. LEWIS, Anaheim, Calif., Lodge, No. 1345.  
GEORGE I. HALL, Lynbrook, N. Y., Lodge, No. 1515.  
EMMETT T. ANDERSON, Tacoma, Wash., Lodge, No. 174.  
JOSEPH B. KYLE, Gary, Ind., Lodge, No. 1132.  
HOWARD R. DAVIS, Williamsport, Pa., Lodge, No. 178.  
SAM STERN, Fargo, N. D., Lodge, No. 260.  
EARL E. JAMES, Oklahoma City, Okla., Lodge, No. 417.

### GRAND FORUM

JOHN L. WALKER, *Chief Justice*, Roanoke, Va., Lodge, No. 197, Box 720.  
JOHN F. SCLEPPI (Queens Borough, N. Y., Lodge, No. 878) 41 Boulevard, Malba 57, N. Y.  
J. PAUL KUHN, Aurora, Ill., Lodge, No. 705, Elks Club, 77 Stolp Ave.  
GLEN S. PATERSON, Watertown, S. D., Lodge, No. 838, Box 1.  
JOHN C. COCHRANE, Toledo, Ohio, Lodge, No. 53, 840 Spitzer Bldg.

### COMMITTEE ON JUDICIARY

H. L. BLACKLEDGE, *Chairman*, Kearney, Neb., Lodge, No. 984, Fort Kearney National Bank Bldg.  
WILLIAM S. HAWKINS, Coeur d'Alene, Ida., Lodge, No. 1254, 320-321 Wiggitt Bldg.  
JOHN K. FENTON (Lawrence, Mass., Lodge, No. 65) Land Court, Pemberton Square, Boston 8, Mass.  
A. F. BRAY (Richmond, Calif., Lodge, No. 1251) 422 State Bldg., San Francisco 2, Calif.  
JAY H. PAYNE, Ann Arbor, Mich., Lodge, No. 825, Court House.

### COMMITTEE ON CREDENTIALS

HOLLIS B. BREWER, *Chairman*, Casper, Wyo., Lodge, No. 1353, 1337 East 2nd St.  
L. A. KREBS, Indianapolis, Ind., Lodge, No. 13, 5827 Hartleagan St.

CARL R. MANN, Bnytown, Tex., Lodge, No. 1649, 3214 Wisconsin St., Bnytown "A".  
WILLIAM H. LAUBACH, Little Rock, Ark., Lodge, No. 29, 311 E. Capitol Ave.  
W. S. GOULD, Scranton, Pa., Lodge, No. 123, 408 No. Washington Ave.  
C. E. KLEIN, Goodland, Kans., Lodge, No. 1528, 122 W. Tenth St.  
WM. H. HARTH, Columbia, S. C., Lodge, No. 1190, Box 1292.  
ELWIN L. GLESSNER, Dixon, Ill., Lodge, No. 779, R.F.D. No. 2.  
ARTHUR J. GENESSE, Green Bay, Wis., Lodge, No. 259.

### COMMITTEE ON LODGE ACTIVITIES

EDWIN J. ALEXANDER, *Chairman*, (Aberdeen, Wash., Lodge, No. 593) 212 N. Rogers St., Olympia, Wash.  
JAMES A. GUNN, Mamaroneck, N. Y., Lodge, No. 1457, 437 Mamaroneck Ave.  
THAD EURE, Raleigh, N. C., Lodge, No. 735, State Capitol.  
JOSEPH F. BADER, Lyndhurst, N. J., Lodge, No. 1505, 279 Travers Place.  
WALTER REED GAGE, Manhattan, Kans., Lodge, No. 1185, 1840 Anderson Ave.

### AUDITING COMMITTEE

ROBERT E. BONEY, *Chairman*, Las Cruces, N. M., Lodge, No. 1119, P.O. Drawer 310.  
ROBERT L. PETERSON (Fargo, N. D., Lodge, No. 260) 1010 Second Ave., No. Moorhead, Minn.  
GEORGE D. KLINGMAN, Joplin, Mo., Lodge, No. 501, 1630 W. Fourth St.

### STATE ASSOCIATIONS COMMITTEE

VINCENT H. GROCOTT, *Chairman*, Santa Barbara, Calif., Lodge, No. 613, 1312 Anacapa St.  
MICHAEL M. HELLMANN, Louisville, Ky., Lodge, No. 8, 1503 Kentucky Home Life Building.  
LOUIS A. SPINE, Somerville, N. J., Lodge, No. 1068, Box 223.  
CULLEN H. TALTON, Daytona Beach, Fla., Lodge, No. 1141, 111 Rosalyn Ave.  
WILLIAM S. WOLF, Pontiac, Ill., Lodge, No. 1019, 825 North Ladd.

### RITUALISTIC COMMITTEE

EDWARD W. McCABE, *Chairman*, Nashville, Tenn., Lodge, No. 72, Box 202.  
M. E. H. SMITH, Greeley, Colo., Lodge, No. 809, 1st Nat'l Bank Bldg.  
C. A. KREMSEY (Lakewood, Ohio, Lodge, No. 1350) 211 High Ave., Cleveland 15, Ohio.  
JOHN HAFICH, Minneapolis, Minn., Lodge, No. 44, 14 North Fifth St.  
LEO P. RONAN, Decorah, Ia., Lodge, No. 443, Box 327.

### COMMITTEE ON YOUTH ACTIVITIES

DEWEY E. S. KUHN, *Chairman*, Charleston, W. Va., Lodge, No. 202, Second Floor, Terminal Bldg.  
BRIAN M. JEWETT (Bath, Me., Lodge, No. 934) Woolwich, Me.  
FRANK HISE, Corvallis, Ore., Lodge, No. 1413, 455 Madison St.  
CHARLES C. BOWIE, San Benito, Tex., Lodge, No. 1661, 217 No. Sam Houston Blvd.  
OSKAR O. LYMPUS, Missoula, "Hellgate", Mont., Lodge, No. 388, Western Bank Bldg.

### PENSION COMMITTEE

JOHN K. BURCH, *Chairman*, Grand Rapids, Mich., Lodge, No. 48, 217-219 Division Ave., So.  
CLYDE E. JONES, Ottumwa, Ia., Lodge, No. 347, Union Bank & Trust Bldg.  
HUGH W. HICKS, Jackson, Tenn., Lodge, No. 192, First National Bank.

### NATIONAL CONVENTION COMMITTEE

GEORGE I. HALL, *Chairman*, Lynbrook, N. Y., Lodge, No. 1515.  
CHARLES H. GRAKELOW, Philadelphia, Pa., Lodge, No. 2.  
JOHN S. McCLELLAND, Atlanta, Ga., Lodge, No. 78.  
L. A. LEWIS, Anaheim, Calif., Lodge, No. 1345.  
JAMES T. HALLINAN, Queens Borough, N. Y., Lodge, No. 878.

### NATIONAL MEMORIAL AND PUBLICATION COMMISSION

BRUCE A. CAMPBELL, *Chairman*, 7629 North Fifth Ave., Phoenix, Ariz.  
JOHN R. COEN, *Vice-Chairman*, Suite 301, Equitable Building, Denver 2, Colo.  
JOHN S. McCLELLAND, *Secretary*, Citizens and Southern Bank Bldg., Atlanta 3, Ga.  
JAMES T. HALLINAN, *Treasurer*, General Court House, 88-11 Sutphin Blvd., Jamaica 35, L. I., N. Y.  
EMMETT T. ANDERSON, *Assistant Secretary and Assistant Treasurer*, 756-758 Commerce St., Tacoma, Wash.

### ELKS NATIONAL FOUNDATION TRUSTEES

JOHN F. MALLEY, *Chairman*, 16 Court Street, Boston 8, Mass.  
ROBERT S. BARRETT, *Vice-Chairman*, 404 Duke Street, Alexandria, Va.  
FLOYD E. THOMPSON, *Secretary*, 11 South La Salle Street, Chicago 3, Ill.  
CHARLES H. GRAKELOW, *Treasurer*, Broad Street at Cumberland, Philadelphia, Pa.  
L. A. LEWIS, Box 628, Whittier, Calif.  
EDWARD J. McCORMICK, 310-314 Ohio Bank Bldg., Toledo 4, Ohio.  
SAM STERN, 102 Seventh St., Fargo, N. D.

### ELKS NATIONAL SERVICE COMMISSION

JAMES T. HALLINAN, *Chairman*, Room 3257, 101 East 42nd St., New York 17, N. Y.  
HENRY C. WARNER, *Vice-Chairman*, Dixon, Ill.  
E. MARK SULLIVAN, *Secretary*, 209 Washington St., Boston 8, Mass.  
GEORGE I. HALL, *Treasurer*, 21 West Street Bldg., New York 6, N. Y.  
HOWARD R. DAVIS, *Asst. Treasurer*, 919 Heppburn St., Williamsport, Pa.  
FRANK J. LONERGAN, Court House, Portland, Ore.  
WADE H. KEPNER, 1308 Chapline Street, Wheeling, W. Va.  
EMMETT T. ANDERSON, 756-758 Commerce Street, Tacoma, Wash.  
JOSEPH B. KYLE, 6114 North Meridian St., Indianapolis 20, Ind.  
WILLIAM H. ATWELL, U. S. District Court, Dallas, Tex.  
CHARLES E. BROUGHTON, 613 Center Ave., Sheboygan, Wis.



# DIY

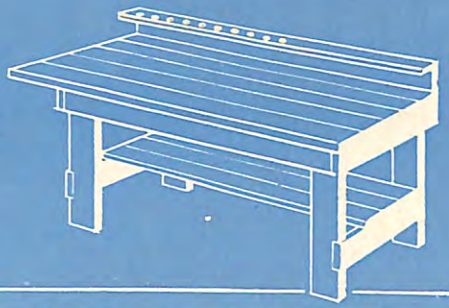

## WORKSHOP

### How to hang things to walls—and make them stay.

BY HARRY WALTON

**F**OUR walls don't make a home until you've hung up the pictures. Other putting-up chores may involve calendars, can openers and cabinets, so no one method will apply to all of them.

In deciding how to do any such job, these points must be considered:

- How heavy is the object?
- Is it a static load, like a picture, mirror, or clock, or is it subject to varying strain, as are bookshelves, towel racks and can openers?
- What kind of wall is it to go on?

*Hanging featherweights.* Small pictures, calendars, plaques, and the like can be hung on plaster, plaster-board or wood walls with  $\frac{3}{4}$ " or 1" brads (thin headless nails). To minimize chipping of plaster, measure if necessary and mark the spot (second guesses leave

that they cling only to the top layer of paint and if overloaded may not only drop what they are holding but rip off a chunk of finish besides.

Wood holds firmly. On walls made of wooden boards, the lowly nail will hold respectable loads. If picture and mirror

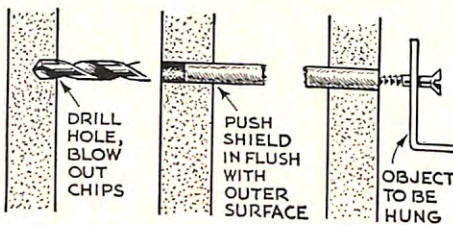

2. USING FIBER SHIELDS

corners are the right length, the article itself will hide the supporting nail. Picture hangers are even better. Wood screws are stronger still.

Driving screws or nails at an angle gives them much greater resistance to shear stress, the kind exerted by a heavy mirror or picture. Where the screw goes through the object itself, especially if it is subject to handling stress (such as a pencil sharpener) drive the screw straight, but all the way in. If such things are left even slightly loose, they will tend to pull the screws out.

Be sure to make pilot holes small enough to give screws a good grip. For small screws in soft wood you can punch holes with an awl. For others, use a drill three fourths the diameter of the screw threads. The hole should be a little shallower than the depth the screw will penetrate.

Even where walls are tile or plaster, you may be able to mount some things



3. IMPACT DRILL

on window or door trim. This is thick enough to provide a good hold, and calls for nothing fancier than wood screws.

Treat Plaster gently. Except for brads, ordinary nails should not be used in plaster walls. Picture hangers are satis-

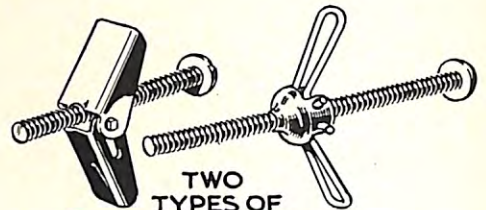

4. TWO TYPES OF TOGGLE BOLTS

factory. They have sharp points to penetrate readily, and the shaped bracket guides the nail. Big ones will support up to 50 pounds. To install them, first pull the nail back until the point barely projects. Hold the bracket flat against the wall and tap the nail gently to start it. Then drive the head all the way to the bracket.

Removing a nail or hanger will often damage plaster, so try to get it at the right spot the first time. If you must remove one, grasp the nail head with pliers and pull gently upward at the angle at which it was driven, twisting back and forth slightly at the same time.

Driving screws in plaster. Wood screws alone have little holding power in plaster or plaster board, unless you can drive them into one of the studs—the wooden uprights—inside the wall. All frame houses have studs, even if the outer walls are brick veneer, stucco, or asbestos shingle. Solid brick and concrete-block houses do not.

Finding the studs is the problem. Some do it by tapping on the wall—it sounds more solid over a stud. On plas-

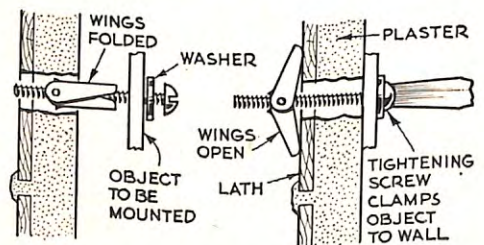

5. USING TOGGLE BOLTS

ter-board walls, the joints come over studs. If nailheads show in the baseboard, they should be over studs (see Fig. 1); you can drop a plumb line (any cord with a small weight on the end) to trace the stud up the wall.

If you plan to paint or wallpaper anyway, or to mount something that will hide a row of small holes, you can drill through the plaster to find the studs. Where the drill bites into wood instead of falling through, you've got one.

Finding one stud may enable you to locate others by measurement, for standard stud spacing is 16" between centers.

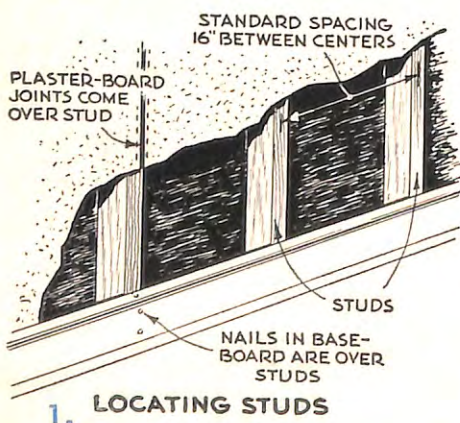

1. LOCATING STUDS

messes!). Hold the brad at a 45-degree slant and drive in all but  $\frac{1}{4}$ " or so to hang the cord on. A trick that helps keep plaster intact is to stick a bit of clear cellophane tape firmly over the spot *before* you drive the brad.

Some new adhesives are strong enough to hold small objects on a wall. Light hangers that need only be moistened and stuck on are available. But remember



But this is not universal. One place you can always find studs, however, is in the corner between two walls.

Lacking studs, you can fall back on some useful little gadgets called expansion shields. These are plastic or fiber bushings which are pushed into a drilled hole. An ordinary wood screw is then driven in, as in Fig. 2.

The bushings are available to fit several sizes of wood screws, but they must match, so it is well to buy the shields and screws at the same time. You also need the right size of drill. A twist drill

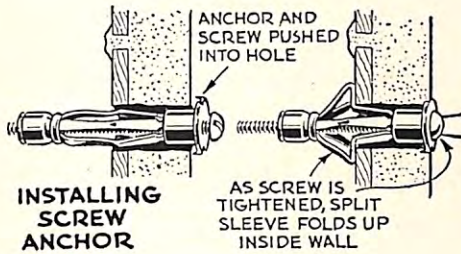

6.

will do, but plaster will dull it quickly. Use an old one if possible.

Worth buying because it will make holes in plaster, brick, stone or concrete, is a little gadget called an impact drill (Fig. 3). Made of high-speed steel, this has a triangular shank and point. Hold it where the hole is wanted and tap with a hammer. Give it a quarter turn and tap again. Keep it straight or the hole will be oversize, and don't hit hard—you'll only jam the drill.

Whatever drill you use, blow out chips (with eyes shut) and insert the shield carefully so as not to break it. For short screws, fiber shields can be cut.

Holding from inside out. Cabinets and other heavy loads may be too much for screws and shields. If you cannot mount them on studs, use a fastener that gets behind wallboard or plaster to lock the load securely.

One of these is the toggle bolt (Fig. 4). A spring type has two wings with a spring that forces them apart. Another

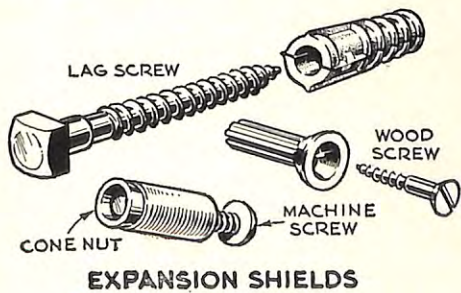

7.

kind has a single wing that turns crosswise of its own weight. To use either, unscrew the bolt first and pass it through the object you want to mount as in Fig. 5. Then screw on the toggle, collapse it, and push it through. When the wings snap out, tighten the bolt. Don't unscrew



it again, for the toggle will fall off inside the wall.

Another expansion shield for hollow walls is shown in Fig. 6. It is easy to use because you can install the shield first and then mount the object it is to hold. Drill a hole, push the shield in, and tighten the screw to spread the split sleeve. Then remove the screw to attach the cabinet or other fixture.

Mounting things on tile. Fiber expansion shields will hold in tiled walls. The holes can be made with an impact drill. To avoid chipping off large areas of the glaze, use a sharp prick punch first to chip the coating away over a small area.

Hanging things on masonry. To hang accessories on a brick fireplace, fix a grate in a backyard barbecue, put up cellar shelves or attach a porch lamp to



a stucco wall, you have several choices. Small lead expansion shields (Fig. 7) expand and lock when wood screws are driven into them. Large ones will anchor lag screws for heavy loads. Another type are pushed in and then set by driving them with a special punch.

The machine-screw shield (Fig. 7) has a captive cone at the inner end. Tightening the screw draws this in, expanding the shield in the hole. The screw can then be taken out for mounting the object.

To make the big holes these shields require, you can use a star drill (Fig. 8). This is similar to the impact drill and used in the same way, but larger and requires heavier blows. An easier way, if you have an electric drill, is to buy a carbide masonry bit. Its incredibly hard edges will chew a hole in stone, brick or concrete in short order.

A substitute for such a drill is to grip three finishing nails tightly in the chuck of an electric drill. They will skate around a bit, but once started go right into brick, concrete block and even stone. Although they dull fast, they are

easily replaced and cost next to nothing. For small holes, chuck a single nail with the head cut off and the end hammered flat.

A quick way to put up shelves, tool panels and partition walls in a cellar is to use cut nails or concrete nails (Fig. 9). First drive them through the piece of wood you want to nail up; then hold this in position and drive the nail on into the masonry. Should you want to drive a nail by itself for use as a hanger,

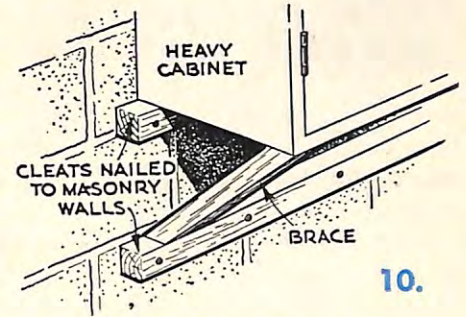

first hammer it through a bit of scrap wood. After driving the nail into the masonry, use a chisel to split the wood away from around it.

For off-the-wall loads that tend to pull the nails out, nail one cleat on to hold the load itself, and another below it as a foothold for braces (Fig. 10).

Modest loads can be held on masonry walls with adhesive-held anchors (Fig. 11). Special mastic is smeared on the perforated plate and this is twisted into place. Let the adhesive set a day before driving the load onto the anchor nail.

★ ★ ★

While most of these articles are available in your local hardware store. Mr. Walton has prepared a data sheet covering sources of manufacture. It is avail-

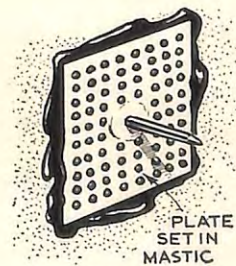

11. ADHESIVE ANCHOR NAIL

able for a three-cent stamp to cover postage by writing to The Elks Magazine, 50 East 42nd St., New York 17, N. Y. Please print name and address. While you are writing, we will be very glad to have your comments on our new Elks Workshop department. This new department was started in our September issue to meet a reader interest need in the "do-it-yourself" field that has become so important.



# Editorial

## DECEMBER



December is generally thought of as a bleak, cold and dreary month.

To the Elks, however, it is a month of warmth.

On the first Sunday of December—at the “Eleventh hour of the year”—the members of our Order gather to

give expression to the warmth of their remembrance of those Brothers who have passed to the great beyond—those absent Brothers whose virtues have been written on the “tablets of love and memory”.

And then later in the month, at Christmas time, there is demonstrated the warmth of their interest in and their sympathy with the less favored ones among us as hundreds of thousands of Christmas baskets are distributed among the needy.

With the Elks, December is surely a month of warmth of sentiment.

## ELKS NATIONAL FOUNDATION AND THE INCOME TAX



This is the last month for those who desire to take such financial actions as will assist them in reducing their reported income for the current year upon which they must pay, or start to pay, their Federal Income Tax in April of the coming year.

In this connection it might be well to have in mind that donations to the Elks National Foundation are deductible from the net income subject to such taxes.

In other words, one who has an income tax rate of 20 per cent on net income could make a donation of \$100 to the Foundation and it would really cost him only \$80 as he would be saving \$20 in his taxes.

A taxpayer whose rate is 50 per cent of net income would pay a tax of \$50 less if he made a \$100 contribution to the Foundation and thus he could make such a contribution and it would cost him only \$50.

A similar rate of reduction of the net cost of making donations to the Foundation would result whatever the amount of the donation.

It is frequently emphasized by Past Grand Exalted Ruler John F. Malley, Chairman of the Elks National Foundation, that:-

*“All contributions to the Foundation are deductible for Federal Income and Estate Tax purposes in the manner and to the extent provided by law.”*

When we started to write this editorial we intended simply to emphasize the fact that such contributions as might be made to the Foundation were deductible from taxable income and thus would call for a much less expenditure than would otherwise be the case.

Now that we are on the subject it seems in order that we

should remind all of the Elks, or other possible subscribers to the Foundation, that any money that they do subscribe will remain permanently intact in the funds of the Foundation and that the income only will be distributed.

The income from one's donation, however, will continue indefinitely during the years ahead to assist in providing scholarships for young men and young women who otherwise might be deprived of their education, to aid in the restoration of crippled children, to care for the victims of tuberculosis and to assist in qualifying doctors, nurses and therapists to take a vital part in bringing victims of cerebral palsy into normal physical and mental activity.

## “NOTHING BUT THE BEST”



Often in the past, as we have looked over the many shining facets of the Order of Elks—its varied benevolences, its patriotic objectives, its high ideals as expressed in the preamble to the Order's Constitution, its social functions for the members and their families—

we have tried to center on one thought that would express both the motivating force behind these splendid aims and activities and the result issuing from them.

At last, we feel that we have found it—one wonderful quality of this Order that at least is the most significant at this season of the year. For it, we are indebted to John W. Gulick, Jr., who resides in Hollywood, Florida, and who is a member of Pensacola Lodge No. 497.

Recently, this Brother wrote to Secretary John Cole of his home Lodge and mentioned that he was planning to visit the Elks Lodge in Hollywood. “When I do”, he said in his letter, “I shall give them the best wishes and kindest regards from Pensacola Lodge No. 497. While I realize I have not been authorized to speak for our Lodge, I do not feel, in such a matter, any authorization is necessary because. . . .”, and these are the words that struck home, “. . . it goes without saying that all members of Elksdom wish all others nothing but the best.”

When, at this season of the year, we are reminded of mankind's age-long craving, the thought that all Elks wish each other “nothing but the best” soars in importance. It suggests that our Order of 1,140,000 members exemplifies an ideal way of life, a way of life that might serve as a beacon, not only to the remainder of our own people, but to other peoples of this sphere, cultured and primitive alike.

We have seized on this spirit of well-wishing as an outstanding achievement of Elksdom because it seems to us that when an association of people has reached such an end in human existence that the members think “nothing but the best” of each other—not for one day on December 25th, nor for one week at the height of the Christmas holiday season, but rather straight through the calendar—they serve to lead humanity toward the realization of its most cherished yearning—

PEACE ON EARTH, GOOD WILL TO MEN.



# \* OFFICIAL ELK JEWELRY

**A Christmas gift every Elk will proudly receive**



EXACT SIZE OF PINS

OFFICIAL ELKS INSIGNIA BUTTONS are now available for the use of members of the Order. The Grand Lodge at its Session last July, authorized the National Memorial and Publication Commission to select official Elk button designs. Designs submitted by one of the outstanding jewelry manufacturers were approved by the National Memorial and Publication Commission and the Advisory Committee of the Grand Lodge. The Commission delegated the purchase and sale to The Elks Magazine. The prices below include insurance, postage and Federal excise tax, excepting when items are purchased for resale the excise tax is not included. Purchases for delivery in N.Y.C. add 3% to prices.



No. 1—50 year emblem. Beautiful, 10k gold with gold plated post and attaching button and five single cut sparkling 2-point genuine diamonds. Price \$78.85. A splendid gift to honored members or officers. No. 1A—Same design, set with five blue sapphires. \$19.25.



No. 6—40 year membership pin, with one diamond inset, 10k gold, gold plated post and attaching button. One 2-point single cut diamond inset. \$22.00.

No. 6A—Same design without diamond. \$8.25.

No. 5—The pin shown below is 15 year membership pin and of same design as 10 year membership pin described below. \$7.35.



No. 2—Plain 50 year membership pin with no jewel but brilliantly enameled red, white and blue. 10k gold with gold plated post and attaching button. \$11.00.



No. 3—25 year membership, plain (no jewels) 10k gold with gold plated post and attaching button. Handsomely enameled red, white and blue. \$8.25.

\* Registered designs of the B.P.O.E. TM and © applied for.

Delivery of merchandise can be expected within two weeks from receipt of order.



No. 8—Honorary life membership pin. 10k gold, gold plated post and attaching button. \$9.15.

No. 8A—Same design with three 2-point blue sapphires. \$13.75.

No. 8B—Same design with three 2-point diamonds. \$49.50

No. 4—10 year membership pin. No jewel but same fine craftsmanship in design and finish of all pins listed here. 10k gold, gold plated post and attaching button. \$7.35.



No. 7—Membership pin without years designation. 10k gold, gold plated post and attaching button. \$7.35.

No. 7S—Same as No. 7 but set with one 4-point genuine blue sapphire. \$11.00.

No. 7A—Same design with 2-point diamond. \$20.15.

No. 7B—Same design with 4-point full cut diamond. \$28.40.

**NOTE: To Dealers and Lodges**

The Elks Magazine will be glad to quote special discounts to dealers and to Lodges for resale to members.

All Pins Manufactured By L. G. Balfour Co., one of America's Leading Manufacturing Jewelers

**THE ELKS MAGAZINE**  
50 East 42nd Street,  
New York 17, N. Y.

Enclosed is check for \$..... for emblem button  
—please send selection checked below—

- |       |        |        |        |        |        |
|-------|--------|--------|--------|--------|--------|
| No. 1 | No. 1A | No. 2  | No. 3  | No. 4  | No. 5  |
| No. 6 | No. 6A | No. 7  | No. 7S | No. 7A | No. 7B |
| No. 8 | No. 8A | No. 8B |        |        |        |

Name.....  
Street.....  
City.....State.....



Merry, Merry,  
Merry, Merry  
Christmas!



OF THE GRANDEST  
GIFTS YOU CAN  
GIVE FOR PURE  
SMOKING PLEASURE!

R. J. Reynolds Tob. Co.  
Winston-Salem, N. C.

### CAMEL

America's most popular cigarette for Christmas-giving. For more pure pleasure, no other cigarette is so rich-tasting, yet so mild as Camel!

### CAVALIER *King Size*

The king-size cigarette that gives an extra measure of both sides of smoking pleasure — mildness to feel . . . flavor to taste!

### WINSTON

*King Size, Filter Tip*

The new, easy-drawing filter cigarette with the finer filter and finer flavor. Winston tastes good — like a cigarette should!

### PRINCE ALBERT

*Smoking Tobacco*

Year after year, America's most popular smoking tobacco. Give the 1-lb. tin to your pipe-smoking friends!



*All  
Daily  
Packaged  
Ready to  
Give*