

THE  
**Elks**  
MAGAZINE



JULY 1956

**YOUTH DAY SALUTE  
TO JUNIOR CITIZENS**

W



# World's largest-selling beer

*...and refreshing as all outdoors!*



Day after day, light, refreshing Schlitz gives more satisfaction to more people than any other beer in the world. It outsells all others by millions of cans, bottles and draughts!

The reason is clear. Schlitz looks and tastes the way Americans like beer today. A clean, bright answer to thirst! Never filling. Never bitter. Brewed with just the *kiss* of the hops. This is the quality that makes and *keeps* so many friends for Schlitz.



**THE BEER THAT MADE MILWAUKEE FAMOUS**

©1956 Jos. Schlitz Brewing Company, Milwaukee, Wis., Brooklyn, N. Y., Los Angeles, Cal.





## TOM WRIGLEY WRITES FROM WASHINGTON



**T**HE giant jet bomber of today becomes the super-deluxe passenger airliner of tomorrow. Production of war planes and development of commercial aircraft go hand in hand. On the armed services side, engineers plan destruction; on the civilian side they seek safety. In military aviation much is said about the great strides reportedly made by Russia in planes and guided missiles. Our defense chiefs are not unduly disturbed by these reports. We, too, have the long-range planes, the H bombs and the guided missiles. Moreover, we have the American "know-how" and the best pilots, navigators and gunners in the world. There is a lot of talk about 5000-mile missiles, but few facts.

Lester Barlow, explosives genius who gave this reporter many a story way back in World War I days, recently has been in Washington advocating the 2000-mile missile rather than the 5000-mile rocket. He says the 2000-mile shell can be fired with remarkable accuracy and one plane can carry several compared with one 5000-mile missile, which cannot be pin-pointed on a target at such long range. In World War I, Barlow gave the government many deadly inventions and then, after many years of bitter litigation, finally won a \$600,000 claim for his work. One of his death-dealing devices caused a bomb, dropped from a plane, to explode several feet above the ground.

### SEEK REPORT ON COURTS

Lawyers throughout the country are approving the suggestion of Deputy Attorney General William P. Rogers that the Chief Justice of the U. S. Supreme Court address Congress at the opening of each session on the state of the Federal Courts. It would follow the President's message on the state of the Union.

### PENGUIN A DOORMAN

One of the big penguins in the National Zoo escaped and walked six blocks along Connecticut Avenue to a movie theater where it stood at the entrance looking just like a doorman wearing a tux.

### FOR YOUR PROTECTION

The Food and Drug Administration starts this fiscal year with plans to expand its working force of 900 to a total of 1,000, but it is still one of the smallest

units of the Health, Education and Welfare Department. This little group passes upon the purity, safety and correct labeling of foods, drugs and cosmetics to protect the health and welfare of all citizens. There has been a tremendous increase in new drugs, 62 per cent just last year, and the small staff of the New Drug Branch is putting in over 100 hours of unpaid overtime every week to keep up with applications. Food and Drug is one of the busiest bureaus in Washington and the most modest in its publicity releases. The scientists, it seems, are too busy to take time out to brag.

### MAY RAISE "MONITOR"

There are reports that the hulk of the "Monitor", the famous Civil War "cheese-box on a raft", has been located on the bottom of the Atlantic off Cape Hatteras and an attempt may be made to raise it.

### PRESIDENTIAL DINNERS

Most tiring and exhausting of all engagements of the President are the banquets and dinners. The food is always rich and the President, sitting in the honor place at the head table, is generally under a glare of light. Everybody watches his every move. He has to appear animated and jovial, as though he was having the time of his life. Grand Exalted Rulers of the Elks can well appreciate what a President goes through, sometimes as often as two or three times a week.

### MONEY FOR SATELLITES

If the first man-made satellite doesn't work, when they shoot it into the skies from Florida, scientists will keep on trying until they perfect one that will circle the earth. Dr. John P. Hagen, Navy expert in charge of the experiment, says they have \$19,000,000 in the budget, enough to build 12 of the rockets.

### WHOOFS FOR CRANES

Late returns to Interior Department's Fish and Wildlife Service indicate that all but two of the last surviving whooping cranes, 27 in number, made their 2500-mile northern flight okay from the Aransas refuge in Texas to Great Slave Lake in Canada. They are nesting now and it is hoped they will raise more than the eight young cranes of last year, which

brought the flock to 28. One crane got lost in Texas and so there are 27. Two stayed in Texas.

### PANTS POCKET LOSSES

Men lose \$48 million a year out of their pants pockets, not including what friend wife snitches, a Made-To-Measure Guild survey shows. Deeper pockets might be the answer but most men say they're already deep enough for what they have.

### SEAMEN DESERVE MEDALS

Smithsonian Institution has a rare seal presented by the crew of the "USS Glacier" whose devotion to duty deserves a special citation. A member of the expedition shot the seal in the Ross Sea as the "Glacier" was plowing through the Antarctic ice pack, and it was put in the ship's deep freeze. The "Glacier", delayed by storms on its 20,000-mile return trip, ran out of meat and only had sardines and salmon. For a time it looked like the 400 pounds of seal in the locker would be carved up in steaks and to heck with science, but the crew kept on eating sardines.

### CAPITAL CALORIES

Army engineers have perfected an automatic fox-hole digger. All you do is light the fuse and, bang, it's dug . . . TV election campaign costs for both parties are now estimated at \$6 million . . . CD says 300 nuclear missiles properly exploded would render useless most installations in a 60,000 square mile area . . . Motor Vehicle Bureau here has new machine to test "corner-of-eye" vision. Tells how much you can see at the side while looking straight ahead . . . Congressman Oliver P. Bolton of Ohio suggests that clear and uniform names be placed on all government buildings so sight-seers will know which is what . . . Since the war your government has spent \$54 billion on foreign aid . . . Generous Uncle Sam has notified 30,000 government workers that if they install their own air conditioners, the government will furnish the electricity . . . Scientists of the Army Map Service, after a terrific amount of computing, say the world is a half mile shorter around the middle than the accepted 24,902 miles. Maybe Mother Earth has been dieting.



# HOW \$6 STARTED ME ON THE ROAD TO \$10,000 A YEAR

By a Wall Street Journal Subscriber

"Not long ago I picked up The Wall Street Journal in a railroad club car. I was amazed. I expected dull reading. Instead I found some of the best articles I ever read.

"I sent \$6 for a trial subscription. For the first time in my life I understand why some men get ahead while others stay behind. The reports in The Journal come to me DAILY. I get quick warning of any new trend affecting my income. I get the facts in time to protect my interest or make a profit. The Journal started me on the road to \$10,000 a year."

This story is typical. The Journal is a wonderful aid to men making \$7,000 to \$20,000 a year. To assure speedy delivery to you anywhere in U. S., The Journal is printed daily in four cities—New York, Chicago, Dallas and San Francisco.

The Wall Street Journal has the largest staff of writers on business and finance. It costs \$20 a year, but in order to acquaint you with The Journal, we make this offer: You can get a Trial Subscription for 3 months for \$6. Just send this ad with check for \$6. Or tell us to bill you. Address: The Wall Street Journal, 44 Broad St., New York 4, N. Y. EM-7

NEW FROM BURROUGHS!



FOR THE

## PENNY-WISE



Dependable. Nimble. A snap to operate. And this new Burroughs Thriftline adding machine is so gratifyingly low priced, too. Hand operated—that's where the big savings begin.

Another pleasant plus: it's now new-penny bright! Rich Amber Gray color makes it so.

Want to try it a while—then decide? Just call our local branch or dealer listed in the phone book. Burroughs Corporation, Detroit 32, Michigan.

### Burroughs THRIFTLINE

ADDING MACHINE



# THE ELKS MAGAZINE

VOL. 35

No. 2

NATIONAL PUBLICATION OF THE BENEVOLENT AND PROTECTIVE ORDER OF ELKS OF THE UNITED STATES OF AMERICA. PUBLISHED UNDER THE DIRECTION OF THE GRAND LODGE BY THE NATIONAL MEMORIAL AND PUBLICATION COMMISSION.

THE ELKS NATIONAL MEMORIAL AND PUBLICATION COMMISSION

JOHN S. McCLELLAND  
Chairman

EMMETT T. ANDERSON  
Vice-Chairman

JAMES T. HALLINAN  
Treasurer

WADE H. KEPNER  
Secretary

CHARLES E. BROUGHTON  
Asst. Secy. and Asst. Treas.

JAMES R. NICHOLSON  
General Manager

LEE C. HICKEY  
Editor

REGINA M. FISHER  
Associate Editor

JOSEPH C. JONES  
Art Editor

GENEVIEVE G. CONOVER  
Advertising Production

W. H. MAGRATH  
Controller

JOHN SCHMITT  
Circulation Manager

EDWARD FAUST  
Promotion Manager

EDITORIAL OFFICES, 386 Fourth Avenue, New York 16, N. Y.

## CONTENTS FOR JULY, 1956

COVER BY WESLEY SNYDER

|                                               |    |
|-----------------------------------------------|----|
| TOM WRIGLEY WRITES FROM WASHINGTON.....       | 1  |
| DEAL OR DIE.....                              | 4  |
| .....Harold Rosenthal                         |    |
| VISITING THE LODGES WITH JOHN L. WALKER.....  | 6  |
| NEWS OF THE STATE ASSOCIATIONS.....           | 10 |
| ROD AND GUN.....                              | 12 |
| .....Dan Holland                              |    |
| YOUR SERVICE COMMISSION.....                  | 15 |
| ANSWERS ANOTHER GOVERNMENT CALL.....          | 16 |
| THEY MADE MAY DAY AMERICAN.....               | 19 |
| A MESSAGE FROM THE GRAND EXALTED RULER.....   | 20 |
| FOR ELKS WHO TRAVEL.....                      | 22 |
| NEWS OF THE LODGES.....                       | 22 |
| .....Horace Sutfon                            |    |
| IN THE DOGHOUSE.....                          | 28 |
| .....Ed Faust                                 |    |
| ELKS FAMILY SHOPPER.....                      | 30 |
| EXCERPTS FROM REPORTS TO THE GRAND LODGE..... | 35 |
| Grand Exalted Ruler.....                      | 35 |
| Grand Secretary.....                          | 36 |
| Board of Grand Trustees.....                  | 38 |
| "FREEDOM'S FACTS".....                        | 39 |
| ELKS NATIONAL FOUNDATION—"Joy of Giving"..... | 45 |
| TRAVELGUIDE.....                              | 46 |
| ELKS WORKSHOP.....                            | 50 |
| .....Harry Walton                             |    |
| EDITORIAL.....                                | 52 |



ADVERTISING OFFICES



CHICAGO 1  
360 North Michigan Avenue  
STATE 2-6662

NEW YORK 16  
386 Fourth Avenue  
MURRAY HILL 4-5495

LOS ANGELES 17  
1709 West 8th Street  
DUNKIRK 8-5187

DETROIT 2  
2970 West Grand Boulevard  
TRINITY 5-7026

SAN FRANCISCO 4  
927 Mills Building  
EXBROOK 2-4073

PORTLAND 4, ORE.  
217 Times Building  
CAPITOL 7-3718

CHANGE OF ADDRESS: POSTMASTER—Please mail Form 3579 notices to: THE ELKS MAGAZINE, 386 Fourth Avenue, New York 16, N. Y.

Members are asked, in changing address, to send this information (1) Name; (2) Lodge number; (3) Membership Number; (4) New address; (5) Old address. Please allow 30 days for a change of address to be effected. THE ELKS MAGAZINE, Volume 35, No. 2, July, 1956. Published monthly at McCall Street, Dayton, Ohio by the Benevolent and Protective Order of Elks of the United States of America. Entered as second class matter November 2, 1940, at the Post Office at Dayton, Ohio, under the Act of October 3, 1917. Acceptance for mailing at special rate of postage provided for in Section 1103, Act of October 3, 1917, authorized May 20, 1952. Printed in Dayton, Ohio. U.S.A. Single copy price, 20 cents. Subscription price in the United States and its Possessions, for Elks \$1.00 a year; for non-Elks, \$2.00 a year; for Canadian postage, add 50 cents a year; for foreign postage, add \$1.00 a year. Subscriptions are payable in advance. Manuscripts must be typewritten and accompanied by sufficient postage for their return via first class mail. They will be handled with care but this Magazine assumes no responsibility for their safety. Copyright, 1956, by the Benevolent and Protective Order of Elks of the United States of America



## What Our Readers



### Have to Say

As a member of Worcester Lodge, for a good many years, I have enjoyed The Elks Magazine immensely and especially your Workshop Department. I find the details that Mr. Walton provides easy to follow and enjoy my hobby of making articles, which appear in this Department.

Peter P. DeFlorio  
Worcester, Mass.

A friend has shown me the April issue, in which your article "Fight Over Fish" discussed the sport vs. commercial fishing controversy. Congratulations for your fairness in not taking either side, but rather giving considerable information on both sides of the controversy.

Henry Engelhard  
Bay Port, Mich.

The Elks Magazine is really a fine publication, and the staff is to be congratulated. Each month I look forward to reading its contents, especially the Editorial Page and "Tom Wrigley Writes from Washington."

Anthony J. Fortunato  
Wilmington, Del.

We received the information from your Travel Service Department and wish to express our sincere thanks. We appreciate the trouble and time that you took in order to provide this information and are sure it will be of great help in making our trip more enjoyable.

Mrs. Marvin Smith  
Albany, Ore.

Your Elks Workshop Department has been of great help and interest to me since I became an Elk and started receiving the Magazine. My wife reads the articles too, and has every copy of the Workshop articles on file for reference.

Clarence A. Evans  
Marshall, Tex.

### THE ELKS MAGAZINE IN NEW OFFICE SPACE

On May 1st, The Elks Magazine moved its offices to 386 Fourth Avenue, New York 16, N. Y., after having been located for thirty-five years at 50 East 42nd Street. The move was made in order to obtain larger space and also to better the coordination of the various departments by placing them on one floor. We would appreciate it very much if readers will take notice of this change of location and address all communications to 386 Fourth Avenue.

# 3 SECRETS OF COOLER SMOKING

## WITH ANY PIPE

### 1. The Right Tobacco

Experts agree white burley is the finest, coolest smoking tobacco of all. For this reason, many pipe tobaccos contain burley. But not one in over 50 years has ever equalled Edgeworth's way with white burley. Edgeworth tobacco buyers look for a certain type of white burley, grown on well-drained land on sunny hillsides, just like fine wine grapes or fine coffee. Then, like fine wine, these special burleys are aged for years before blending.

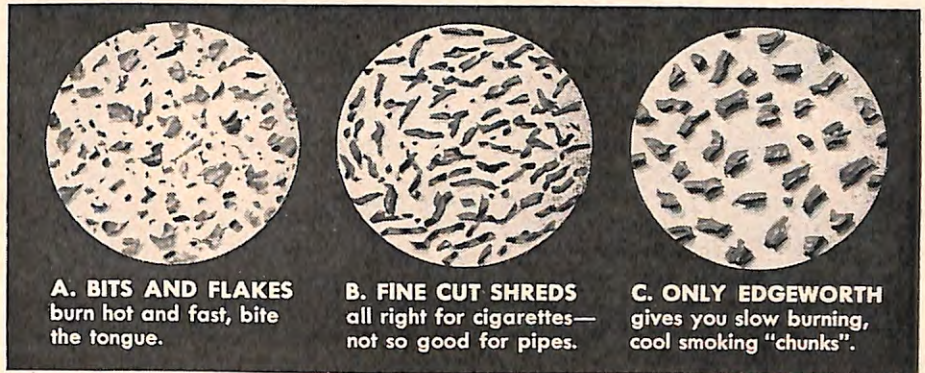

**A. BITS AND FLAKES**  
burn hot and fast, bite the tongue.

**B. FINE CUT SHREDS**  
all right for cigarettes—  
not so good for pipes.

**C. ONLY EDGEWORTH**  
gives you slow burning,  
cool smoking "chunks".

### 2. The Correct Cut

Many a smoker used to rub a slice of tobacco carefully between his palms, until it formed chunks of just the right size to pack right and smoke cool. Now Edgeworth does all this before the tobacco is packaged. No other tobacco manufacturer can duplicate the Edgeworth cut—because it's actually "ready-rubbed" by an exclusive process. See in the picture what a difference this makes. Edgeworth's even-sized chunks (Picture C) burn slow and cool with never a touch of tongue bite. No other tobacco is "ready-rubbed" like this. And tests show that Edgeworth smokes 8 to 10 degrees cooler than other tobaccos tested.



### 3. Factory Freshness

Edgeworth's exclusive wrap-around pouch is heat-sealed. Moisture can't get in—proof that freshness can't get out! And no bulky corners in your pocket. You can always count on Edgeworth, America's finest pipe tobacco for over 50 years.

LARUS & BROTHER CO., INC.  
RICHMOND, VIRGINIA

**AMERICA'S COOLEST  
SMOKE**  
(8 TO 10 DEGREES  
COOLER)



# EDGEWORTH

AMERICA'S FINEST PIPE TOBACCO



# Deal



ILLUSTRATED BY WILLARD MULLIN

Willard Mullin



# or Die

**BY HAROLD ROSENTHAL**

**D**URING the past decade major-league baseball frequently has bent like a reed before the combined impact of the personalities of such front-office men as Frank Lane, George Weiss and Branch Rickey. If you pooled the scouting staffs of all sixteen major-league organizations and dispatched them to the far corners it would be difficult for them to uncover three men with more divergent approaches to life. Yet this trio has demonstrated time and again a unique bonding baseball characteristic—an amazing ability to pulverize you in a trade.

Rickey is pretty much emeritus at Pittsburgh now but Weiss and Lane continue to roll along under that same head of steam—planning, plotting, watching, waiting, and finally, dealing. Of such things are successful baseball dynasties made; deals wherein a club's most valuable personnel assets are seemingly bandied and tossed about in a trivial manner positively frightening to the on-looker.

In baseball today the word is deal or drop out of the parade to make way for someone who will. In life the biological rule is that nothing can remain static; it has to move, up or down. The same holds for baseball. Clubs on top have to deal to stay up there; the second-division members have to leap into the monster poker game in an effort to climb into the sunlight of success on the field which brings an accompanying success at the box-office.

Deals are the spice of the off-season sports-pages and cracker-barrel conclaves. Occasionally a giant swap or sale right smack in the middle of the pennant campaign will cause the surrounding box-scores to swim and gyrate crazily in the reader's line of vision. Think of how they effect (a), the slumbers of the baseball men who have shaken hands on the deal and (b), the baseball men who haven't.

If it was a simple matter of deal-or-die, baseball men could learn to live with that constant prod. There's more to it, though, an angle even more terrifying. It's the thought that while you have to deal to help yourself it's the deals you DON'T

make that could turn out more valuable in the end.

A couple of winters ago the Cincinnati Redlegs' general manager, Gabe Paul, and his Brooklyn opposite number, E. J. (Buz) Bavaši, shook hands in a smoke-filled Houston hotel room. Dawn was just breaking, the final details had been worked out.

There were a total of perhaps a half-dozen players in the agreed-upon deal but it really boiled down to Jim Gilliam, the Dodgers' second baseman, for Fred Baczewski, a lefthander who had been singularly effective against the Dodgers and Wally Post, an outfielder who had been up and down several times with Cincinnati.

All the baseball men attending the minor league meetings were going on to New York where the major-league segment of the conclave were to take place. Bavaši and Paul were among them. "Okay, it's a deal," declared this pair of youngish baseball administrators. "See you in New York."

On the plane North the details of the deal were leaked to one or two New York newspapermen. It was a big story in Monday's New York papers, but there was a bigger one to cap it the following morning. Brooklyn had changed its mind. The deal was off.

Renegé? A little. It's a baseball prerogative. Nothing was in writing. The Dodgers weren't the first, nor will they be the last, to say, "Ahem, about that little talk we had . . ."

**P**AUL still figuratively mops his brow over what would have happened had that deal gone through. Post clouted forty homers last year for the Redlegs. It is pretty safe to assume he'd have hit that many, probably more, in the friendly confines of Ebbets Field.

A Brooklyn outfield of Post-Duke Snider-Carl Furillo would have accounted for well over a hundred homers. The Dodgers, winners of the pennant by 13½ games, possibly could have won by twice that many. With all semblance of competition gone from the National League race by perhaps Aug. 1, financial disaster, acute and real, could have struck the senior loop. Paul had good reason to

**There's no standing still in baseball. Win or lose on the deal, you have to trade to stay on top—or drop out of the parade and make room for someone who will.**

heave a sigh of relief over the deal that was made, then unmade. So, it would seem, have some pretty important people in baseball.

The important thing about this no-deal is that not a nickel would have changed hands. Yet the fate of an entire league for perhaps three or four seasons would have been riding on it. For Brooklyn it would have been a "good deal." For Cincinnati and the rest of the National League it could have been a nightmare.

What constitutes a "good deal" in baseball? Bill DeWitt, assistant general manager of the Yankees, thinks the answer is a simple, "One that will help you the most." Attached to this explanation is a small rider, "depending on what kind of help you need."

Help is help, you say? Not in baseball. A pitcher who can win five games for a club mired in seventh place late in the season might be worth the waiver price of \$10,000, if the front office thinks he might be able to help some the following season. That same player, to a club fighting for the current pennant, could be worth ten times that figure.

Every year since he has taken over Casey Stengel has had front-office help with his Yankee pitching. They've skimmed the cream of the Yankee farm system for Casey, of course, but every year there has been that important deal—players, waivers, cash, cigar coupons, and green stamps for the pitcher who could help. That crack, "lucky Yankees" fades in face of a parade of names like McDermott, Larsen, Turley, Byrd, Blackwell, Sain, Ferrick, Ostrowski, Sanford and Byrne.

Certainly a good portion were flops. The ones who came through, though, meant the difference in Stengel's drive to six pennants and five World Series in his first seven years as Yankee boss.

"A good dealer in baseball," said DeWitt, who himself was once the recipient of the highest single check ever written in payment for baseball talent, "is one who is able to decide where he needs help the most. He must also have imagination, should be able to absorb the right amount of advice, and should be able to proceed with confidence in the knowledge that he

*(Continued on page 41)*



# Visiting the Lodges with John L. Walker



When the Grand Exalted Ruler was at Daytona Beach, Fla., on March 16th, he placed a wreath at the monument of PGER David Sholtz, and present from left were: PGER Robert S. Barrett, Mr. Walker, former member Grand Lodge State Assn. Committee Cullen H. Talton, Grand Trustee W. A. Wall, Grand Lodge Activities Coordinator Bert A. Thompson and DD William Lieberman.



With Mr. and Mrs. Walker at Columbus, Ga., Lodge, on March 7th, from left: PGER John S. McClelland and ER John Nilan.



Lodge officers and Grand Lodge dignitaries welcomed Mr. Walker to Griffin, Ga., Lodge on March 7th. Present from left: D. G. Brisendine, M. A. Froberg, C. B. Pierce, Jr., Rev. Walter Kuhn, F. D. Hunt, Charlie Kite, PGER John S. McClelland, Philip Williams, Mr. Walker, ER Charles E. Charlton, DD Guy Tyler, Grand Lodge Activities Committee Member Robert G. Pruitt, J. Arnold Wood, Homer Grissom and Sec. C. J. Williams.



When Wilmington and Dover, Del., Lodges honored the Grand Exalted Ruler on April 4th, present from left were: PDD Lee D. Buckley; DD William K. Cary; Charter Member Joseph Martin; Past Grand Esteemed Loyal Knight Charles G. Hawthorne; Mr. Walker; ER, Wilmington Lodge, Alfred D. Russo; ER Havre de Grace Lodge, Charles H. Voelker; ER Dover Lodge, Carmine Pisapia; PER Alton H. Jacob; Pres. Tri-State Elks Paul Schutt, and PDD Perry Topkis.



On March 8th, the Grand Exalted Ruler was at Atlanta, Ga., Lodge for luncheon, and present at the speaker's table were, from left: PGER John S. McClelland, Mrs. Walter P. Andrews, widow of PGER Andrews, Mr. and Mrs. Walker, Mrs. L. D. Burns, Jr., and PER L. D. Burns, Jr.

COMPLETING the visits to Alabama lodges reported in the June issue, during the afternoon of March 6th, Grand Exalted Ruler John L. Walker and Mrs. Walker were escorted to **DOTHAN, ALA.**, by Exalted Ruler B. W. Connell and Dothan's Mayor, Richmond McClintock. Immediately upon arrival, the Grand Exalted Ruler went to the local television station, where he received a plaque from the

Southeast Alabama Scout Council in recognition of his outstanding work with Boy and Girl Scouts. He also received from Dothan Lodge an application for a \$1,000 Founder's Certificate in the Elks National Foundation.

The Grand Exalted Ruler and Mrs. Walker, together with numerous guests from Alabama, Florida and Georgia, attended a reception at Dothan Lodge, fol-

lowed by a banquet and dance at which more than 300 were present.

District Deputy L. P. Patterson acted as Toastmaster and Exalted Ruler Connell and Mayor McClintock extended welcomes to the guests. Response was made by District Deputy A. C. Van Horn, Jr. of Panama City, Florida. Past Grand Exalted Ruler John S. McClelland introduced Mr. Walker to the guests and in closing his inspiring address on Elksdom the Grand Exalted Ruler congratulated Alabama's baby lodge on the occasion of its Third Anniversary and also praised its works of charity and its interest in youth activities. Included among the guests were State Association President C. E. Haywood; Special Deputy Ray C. Balthrop; Bert A. Thompson, Grand Lodge Activities Coordinator, as well as a number of Exalted Rulers, past and present Grand Lodge and State Association officers, and their ladies.

Mr. and Mrs. Walker were guests at a luncheon on March 7th given in their honor by **COLUMBUS, GA., LODGE**. The luncheon was attended by Past Grand Exalted Ruler John S. McClelland and Major General Joseph Harper, Commander of Fort Benning and The Infantry School. General Harper is the distinguished soldier who was in command in the siege at Bastogne during World War II, and, pointed out PER John J. Nilan, "he has worked very closely with our lodge and



This portrait of Mr. Walker was presented to him when he visited Everett, Mass., Lodge on April 1st. Holding the portrait from left are ER Charles M. Zellen and PER John J. Rocco.





L. H. Christian of Athens, Ga., Lodge makes a presentation to the Grand Exalted Ruler during his visit on March 8th. Looking on are Mrs. Walker and ER Raymond E. Lester.



At Elberton, Ga., Lodge on March 9, left to right: ER Zack McLanahan, Mrs. John L. Walker, Mr. Walker, Mrs. McLanahan, DD Henry M. Rosenthal and State Pres. Marston S. Bell.



Reviewing the Wheeling, W. Va., Drill Team at Oglebay Park on April 5th were, from left in the foreground: PER Wallace, Mr. Walker, PGER Wade H. Kepner and ER Goodwin.



At the Missouri Elks Assn. meeting at St. Joseph, May 4-5, were, from left: ER Earl C. McAllister, GER John L. Walker, State Pres. Francis B. Karr and PGER Joseph B. Kyle.



On hand when the Grand Exalted Ruler visited Pulaski, Va., Lodge on March 23rd, were from left: PER James E. Huddle, C. C. Owens, C. DuVal Seagle, William H. Dent, J. H. Chapman, James W. Steger, Mr. Walker, Sec. David W. Ratcliff, ER Philip M. Sadler, R. B. Oglesby and W. L. Dudley.



When Mr. and Mrs. Walker visited Anderson, S. C., Lodge on March 9th, present front row, left to right: Andy Hutchinson, Hal P. Porter, Mr. and Mrs. Walker, ER Lovic A. Brooks, Jr. and George Shealor. Back row: Pat B. Harris, Harold Hutchinson, Red Ashley, Bobby Gaines and Joseph Watson.

has given us complete cooperation in our soldier program." That evening Mr. and Mrs. Walker were at **GRIFIN, GA., LODGE**, to attend a dinner at which more than 200 Elks and their wives were present. The Grand Exalted Ruler was presented by Past Grand Exalted Ruler John S. McClelland and Exalted Ruler Charles E. Charlton was host for the occasion.

The Grand Exalted Ruler's next visit was at **ATLANTA, GA.**, where he was escorted the evening of March 7 by Exalted Ruler M. Tom Bryan, Mrs. Bryan and Inner Guard John W. Brinsfield and Mrs. Brinsfield. The following day Mr. Walker was met by Past Grand Exalted Ruler John S. McClelland, District Deputy Guy

Tyler, Brothers Bryan and Brinsfield, who took him to the grave of Past Grand Exalted Ruler Walter P. Andrews, where he placed a wreath. Mr. Walker was joined by Mrs. Walker for luncheon at Atlanta Lodge. Exalted Ruler Bryan introduced the Exalted Rulers and Secretaries of the five Greater Atlanta Lodges; Rev. Father James E. King, Past Grand Chaplain; Robert G. Pruitt, member Grand Lodge Comm. on Lodge Activities; Lee Evans, PER and Vice-Mayor of Atlanta; District Deputy Henry M. Rosenthal and Special Deputy R. M. McDuffie. PGER McClelland introduced Mrs. Walter P. Andrews. The Grand Exalted Ruler's party visited

*(Continued on page 8)*



Photograph taken when the Grand Exalted Ruler was in Boston for the Mass. Elks Assn. Dinner Feb. 20th. At Mr. Walker's left are State Pres. Michael J. McNamara and Grand Treasurer Edward A. Spry.



Entertaining the Grand Exalted Ruler during his visit to Pascagoula, Miss., Lodge on March 20th, from left: State Pres. Clyde Moss, State Sec. Vincent Ros, Jack Calhoun and ER M. Palmer.



The Stuart-Jensen, Fla., Lodge was host to the Grand Exalted Ruler on March 15th, and present from left were: ER A. Ward Albertson, Mr. Walker, Zack Mosley and Grand Trustee, W. A. Wall.



Present with the Grand Exalted Ruler when he addressed a gathering in Wichita, Kans., early in May was Past Grand Exalted Ruler Henry C. Warner.





During his visit to New England on April 2nd, the Grand Exalted Ruler stopped at Brookline, Mass., Lodge, to attend the installation of officers. Present from left were: PER Newton Lodge, Arthur T. Wasserman; retiring ER George Gettins; PGER John F. Malley; Herman A. Katz, father of the Exalted Ruler; ER Mike Katz, DD Thomas McEnaney, Pres. Mass. Elks Assn. Michael McNamara and PGER E. Mark Sullivan.



Sturgis, Mich., Lodge honored the Grand Exalted Ruler on April 24th at a luncheon, at which present from left, front row, were: Mayor Leo Yoder, ER Bruce Hall, Mr. Walker, member Grand Lodge Judiciary Committee B. F. Watson, Past Pres. Charles T. Noble and DD L. M. Richard. Rear Row: Rev. Richard Dunkleberger, Jack Dunten, DD Dean Wilkenson, State Vice-Pres. at large Robert Burns and Past Pres. S. Glen Converse.

Elks Aidmore for Crippled Children located in Atlanta.

That evening the Grand Exalted Ruler went to **ATHENS, GA.**, and was met at the outskirts of the city by Exalted Ruler Raymond E. Lester and the lodge officers, who escorted him into the city. Mr. Walker was interviewed by Radio Station WRFC.

Early in the evening the Grand Exalted Ruler addressed a large gathering of Elks at the Athens Lodge.

On March 9th Mr. and Mrs. Walker were at **ELBERTON, GA., LODGE**, for luncheon, with Exalted Ruler Zack W. McLanahan and his wife hosts. Exalted Ruler Lovic A. Brooks, Jr., Mrs. Brooks, State Pres.

Marston S. Bell, and Brother Brinson Moorehead and his wife escorted Grand Exalted Ruler Walker and Mrs. Walker from Elberton to **ANDERSON, S. C., LODGE** that afternoon. The party was met at Anderson Lodge by Trustees Pat B. Harris, Andy A. Hutchinson, Hal P. Porter, Barney Smith, Harold Hutchinson and their



Mayor David McLeod extends the official welcome to Florence, S. C., during Mr. Walker's visit on March 10th. Looking on is ER M. M. Marshall.



The Grand Exalted Ruler and ER Guy L. Deano, Jr. discuss Elk affairs during Mr. Walker's visit to New Orleans, La., Lodge on March 19th.



At Winter Park, Fla., Lodge on March 18th, were from left, the Grand Exalted Ruler, PER V. F. Martin and Grand Trustee W. A. Wall.



Member Grand Forum John C. Cochrane (right) accepts check for \$2,000 from ER William Polhemus for the Cerebral Palsy Center when the Grand Exalted Ruler visited Toledo, Ohio, on April 26. Looking on from left are: GER John L. Walker and PGER Dr. Edward J. McCormick.



Presentation of gifts at the Ohio Leather Company, when Mr. Walker visited Girard, Ohio, on April 27th. From left: Member Grand Forum John C. Cochrane, PGER Dr. Edward J. McCormick, Mr. Walker, PER Cleveland Lodge Larry McKenna and Frank Binns of Ravenna Lodge.



En route to Pontiac, Mich., Lodge on April 23rd, the Grand Exalted Ruler stopped at Flint, where he was welcomed, from left, by PER Herbert E. Heath, PER John M. Byers and Mayor George M. Algoe, as ER Karl M. Smith, Jr., shook hands with Mr. Walker.



From left when the Grand Exalted Ruler was at Columbia, S. C., Lodge on March 9th, were: ER Fred W. Ortmann, Jr., Sumter Lodge; ER Gus Fitch, Jr., Columbia Lodge; Pres. S. C. Elks Assn. Marston S. Bell and Mr. Walker.



On April 25th the Grand Exalted Ruler was in Pontiac, Mich., for the dedication of the new home, present from left were: Governor G. Mennen Williams, ER Jack Bender, Past Pres. Michigan Elks Thomas P. Gilotte and Mr. Walker.



Greeting the Grand Exalted Ruler when he arrived at Pompano Beach, Fla., for the dedication of the new home on March 13th were, from left: ER Edward H. Haynie, Grand Trustee W. A. Wall and DD George C. Nichols.





Above: While the Grand Exalted Ruler was at Battle Creek, Mich., Lodge on April 24th, with him from left were: PER R. W. Shulters, Ray M. Dawson, PER V. W. Rouse, ER Nick Gaetano, Mr. Walker, Horace S. Maxwell, Orville A. Smith, Dale B. Rutledge and Charles D. Wilson.

While at Umatilla, Fla., on March 17th, the Grand Exalted Ruler attended a meeting at the Harry-Anna Crippled Children's Home and photographed with the little boy, who is cared for by the Home, were from left: State Pres. Frank J. Holt, Mr. Walker and State Sec. James J. Fernandez.



Right: Greeting Mr. Walker at the station when he arrived at Fredericksburg, Va., Lodge, on April 9, were, from left: PER William P. Wholey, W. Henry Cox, J.A. Edgar Piette, ER Stanley B. Snellings, PER Lafayette H. Biscoe, Mr. Walker, Carl E. Gallahan, William B. Bolton and PER Kuzsner Bauman.



Right: Present on the rostrum when the Grand Exalted Ruler addressed a reception given in his honor at the Fontainebleau Hotel, Miami Beach, Fla., were from left: Thomas F. Smith, PER James P. Wendler, Grand Lodge Activities Committee member James Gunn, DD George C. Nichols, PGER Sam Stern, ER Edward T. Newman, Grand Trustee William A. Wall, and Grand Treasurer Edward A. Spry.

wives. In the evening a banquet was held, following which there was a dance.

The next morning, accompanied by State Pres. Marston S. Bell, Mr. and Mrs. Walker stopped at **COLUMBIA, S. C., LODGE**, where they were greeted by Trustees and officers of the lodge. At noon that day Mr. and Mrs. Walker were at **SUMTER, S. C., LODGE**, for luncheon, to be welcomed by Exalted Ruler Fred Ortmann, Jr. Mayor M. Priscilla Shaw extended the greetings of the city and M. M. Weinberg, Sr., was Master of Ceremonies. Following the luncheon Mr. Walker was escorted to **FLORENCE, S. C., LODGE**, by PER Barfield and Exalted Ruler M. M. Marshall. He was officially welcomed to Florence by Mayor David McLeod. That evening a reception and banquet were held with approximately 250 members of the Order present, including State Pres. Marston S. Bell and Past District Deputies W. H.

Turner, Christopher F. Hottinger and Louie Burmaster.

Mr. and Mrs. Walker arrived at **MIAMI BEACH, FLA.**, on the afternoon of March 11th, and the welcoming party included Grand Trustee W. A. Wall, Past Grand

Lecturing Knight Chelsie J. Senerchia, State Pres. Frank J. Holt, District Deputy George C. Nichols and Exalted Ruler Edward T. Newman. Late in the afternoon a reception and cocktail party were held in  
(Continued on page 47)



Left: Photographed at the Will Rogers sepulchre when Mr. and Mrs. Walker stopped at Claremore, Okla., on May 7 were from left: PER Wm. L. Farbro, Mr. Walker, State Pres. John W. Coons, Mrs. Walker, PER Ernie Smart, Special DD Bert Wysor, ER L. R. Harrington and Sec. Leo Marshall.



Left: On March 18th the Grand Exalted Ruler was in Orlando, Fla., for the dedication of the lodge's new Boy Scout Home. Standing from left: Troop Committeemen John D. Heitz, Stephen Reymer and Charles Klotz; Vice-Pres. Florida E. Central District John W. Morgan; Grand Trustee W. A. Wall; Troop Committeeman Leonard Boehm; Mr. Walker; ER R. F. Buffington and DD William Lieberman. Kneeling: Scouts Charles Stokes and Robert Boehm, Scout Commissioner Cel Wehmeyer, Scoutmaster Dr. John J. Heitz and Eagle Scouts Jeff Hartman and William Phillips.



Members of Lansing, Mich., Lodge with the John L. Walker class on April 24th. Seated from left: Vern Slowinski, PER Donald F. Hatt, the Grand Exalted Ruler, ER Roland D. Shook and Harry Feguer.



# News of the STATE



Past Grand Exalted Ruler Dr. E. J. McCormick is photographed at the podium as he presented the State's Elks National Foundation Awards during the Ohio Elks Association banquet at which Grand Exalted Ruler John L. Walker, seated at right, was the principal speaker. Others seated, left to right, are Mrs. Herschel J. Deal, newly elected State Pres. Deal and Mrs. L. A. Kuenzli.

## FLOYD E. THOMPSON GUEST OF WYOMING ELKS ASSN.

Past Grand Exalted Ruler and Mrs. Floyd E. Thompson arrived in Rawlins on May 4th for the three-day Convention of the Wyoming Elks Assn. That evening, Judge Thompson delivered a splendid address before 450 Elks and their wives at the State banquet during which the barbershop quartet of Casper Elksdom entertained.

Highlight of the first day's activities was the opening session to which the public was invited, when Secy.-Treas. L. G. Mehse, Chairman of the Awards Committee, presented a "Most Valuable Student" \$400 award to Darryl Bind-schadler, a \$200 Future Farmers of America award to Jim Wesley Doughty, the \$200 4-H Animal Husbandry Award to James Trierweiler and the Home

Economics Award of \$200 to Barbara Marie Bell. Later, 56-year Charter Members Ed. F. Bennett and H. Larsen were honored, and 13 Rawlins Elks were given 50-year-membership pins by Oscar A. Hall of that lodge.

The second day's events included the business session at which D.D. H. H. Hecht, P.D.D. J. P. Steele and H. G. Downs, former Pres. of the Colo. Elks Assn. were introduced, and an impressive public Memorial Service at which E.R. Kenneth W. Keldsen presided. Laramie Lodge won the 12-team ritualistic competition, and the trophy award for the largest attendance went to Cody. A trophy for the greatest increase in membership was awarded to Lusk Lodge for the South District, with Worland the recipient for the North.

Elections which climaxed the conclave found George K. Forster of Casper as

1956-57 President. Serving with him are Vice-Presidents R. J. Bertagnolli, Rock Springs; Rowland Jones, Thermopolis, and James T. Groves, Lusk. L. G. Mehse of Laramie is again Secy.-Treas., with Milton E. Nichols, Cheyenne, as Sgt.-at-Arms; Robert H. Morrow, Sheridan, Tiler; Arnold Veile, Worland, Inner Guard; James P. Steele, Laramie, Chaplain, and retiring Pres. Paul H. McKelvey of Rawlins as five-year Trustee.

## DR. McCORMICK REWARDS OHIO SCHOLARS

Five Elks National Foundation Scholarships were presented to their recipients during the 1956 Ohio Elks Assn. Convention by Past Grand Exalted Ruler Dr. Edward J. McCormick. The event was a highlight of the annual State Association banquet at which Grand Exalted Ruler John L. Walker gave the principal address. John C. Cochrane of the Grand Forum, Special Representative Floyd H. Brown of the Elks National Service Commission and five of the State's District Deputies were among the distinguished Elks on hand. The meeting, which opened on April 26th and closed on the 29th, took place at Columbus, which will also be the scene of the 1957 conclave to take place next May.

Reports on the Assn.'s National Foundation work, cerebral palsy activities, veterans service and youth programs were given on a lodge and State level, and the Ritualistic Contest, participated in by top lodges for each district found the Youngtown Lodge entry, representing the Northeast section of the State, in first place.

The following officers will handle the



Right: Photographed during the Missouri Convention at St. Joseph are, left to right, host E.R. and Mrs. Earl C. McAllister, Mrs. John L. Walker, Mr. Walker, Mrs. Francis B. Karr and State Pres. Karr.

Left: During the Oklahoma Elks Assn. Convention Grand Exalted Ruler John L. Walker and Mrs. Walker visited the famous Woolaroc Museum located on the farm of the late Frank Phillips, a devoted Elk and founder of the Phillips Petroleum Co., which is dedicated to the youth of America. Pictured outside the Museum are, left to right, Past State Pres. and Mrs. Arthur J. Hall, Mrs. Walker, the Grand Exalted Ruler, Mrs. John W. Coons and retiring State Pres. Coons and second Vice-Pres. Bert Wysor and Bartlesville Lodge's E.R. Joe J. Collier, Jr.





# ASSOCIATIONS

organization's business for the coming year: Pres., Herschel J. Deal, Canton; 1st Vice-Pres., James W. Plummer, Zanesville; 2nd Vice-Pres., Martin W. Feigert, Van Wert; 3rd Vice-Pres., N. A. Bartram, Youngstown; Secy., L. E. Strong, Canton; Treas., Charles S. Cowie, Cincinnati; Treas. Emeritus, C. W. Wallace, Columbus; Trustees: Chairman Arthur E. Socin, Bucyrus; Dr. D. S. Goldschmidt, Circleville and Secy. J. D. Quinn, Sidney; Chaplain, Fr. Richard D. Connelly, Washington Court House; Sgt.-at-Arms, L. R. Derry, Barnesville; Inner Guard, Harold M. Scott, Portsmouth; Tiler, Wm. C. Rastetter, Canton.

## CLARENCE LaCROIX HEADS LOUISIANA ELKS ASSN.

A Baton Rouge Elk, Clarence LaCroix, was elected President of the Louisiana Elks Assn. at its 20th Annual Convention in Alexandria Apr. 27, 28th and 29th. Over 300 persons were on hand to applaud the address made by U.S. Sen. Russell B. Long, a member of Baton Rouge Lodge whose Degree Team captured the Ritualistic Contest. Another fine Convention speaker was Rev. D. A. Curren, who is Honorary Chaplain of Alexandria Lodge.

Retiring Pres. Dr. Milton Honigman opened the session, with Mayor W. G. Bowdon, Jr., delivering an address of welcome. The President's Cup went to Opelousas Lodge, and \$400 scholarships were awarded to Joan Helveston and Fred C. Sexton, Jr., with John Schwab receiving the Association's Youth Leadership \$100 award.

During this meeting, the Association went on record to continue its sponsorship of the Southern Eye Bank to which it contributes \$5,000 a year. The Eye Bank was instituted in 1947, and for five years found it very difficult to secure financial assistance. It was then, in 1952, that the Louisiana Elks first made their large annual donation.

The 1957 Convention will be held in Shreveport in April. Serving with Mr. LaCroix until that time are 1st Vice-Pres. A. S. Johnson, Jr., Jennings; 2nd



Dignitaries on hand for the Annual Meeting of the Wyoming Elks Association at Rawlins included, left to right foreground, Secy.-Treas. L. G. Mehse, retiring Pres. and D.D. Paul H. McKelvey, Past Grand Exalted Ruler Floyd E. Thompson and D.D. Henry H. Hecht; second row: Past State Pres. K. L. Sehnert, P.D.D. J. P. Steele and Past State Pres. T. Joe Cahill.

Vice-Pres. Arnold Fourroux, Sr., Plaquemine; Secy. (reelected) E. F. Heller, Alexandria; Treas. A. B. Culliton, Shreveport; Sgt.-at-Arms, E. F. Rodriguez, Sr., Alexandria; Tiler, J. P. Ketteringham, Shreveport; Chaplain (reelected) Theo. J. Duhon, Baton Rouge; Trustee (five years) Willis C. McDonald, New Orleans. Other Trustees are Jacob J. Amato, New Orleans; Chas. L. Clay, Opelousas; S. C. Spengler, Alexandria, and Miles J. Byrne, Shreveport.

## JOSEPH B. KYLE ATTENDS MISSOURI ELKS' CONCLAVE

With Grand Exalted Ruler and Mrs. Walker, Past Grand Exalted Ruler Joseph B. Kyle and his wife were among the 410 persons who took part in the May 4th, 5th and 6th Meeting of the Missouri Elks Assn. at St. Joseph. Mr. Walker was an inspired speaker at the dinner held in his honor on the 4th, and Mr. Kyle delivered a compelling address at the banquet the following evening.

The Degree Team from Joplin won the

State Ritualistic Contest, initiating 16 candidates for the host lodge. The Assn.'s Boys Camp near Joplin, its eyeglass program for deserving children and the Elks Benevolent Trust Fund, Inc., an agency for various charitable endeavors, were reviewed. At the business meeting on the 6th, the Benevolent Trust Committee formed a One Hundred Club, each member of which is pledged to donate \$100 to the Trust Fund; at this meeting 35 members were enrolled.

Guy D. Moore of Joplin is the new President of the Assn. and will be assisted by Edward Hunker, St. Charles, as Vice-Pres.-at-Large, and Vice-Presidents O. M. Flory, Nevada, S. W.; George E. Murray, Clayton, East; Clyde J. Ellis, Kansas City, N.W.; Judge D. B. Tammany, St. Louis, Tiler; Omar Muench, Lexington, Marshal; Wm. R. Kublin, St. Louis, Chaplain; Robert Moore, Sedalia, Inner Guard; Brice E. Crouch, Joplin, Secy. Trustees are Harvey Goebel, Webb City; Carl Kelsay, Jefferson City, and Vern Guilley, Trenton.

## STATE ASSOCIATION CONVENTIONS

| STATE                | PLACE          | DATE               |
|----------------------|----------------|--------------------|
| Maine                | Belgrade Lakes | June 29-30, July 1 |
| Illinois             | Springfield    | July 25-26-27      |
| Montana              | Lewiston       | July 25-26-27-28   |
| Pennsylvania         | Reading        | Aug. 19-20-21-22   |
| West Virginia        | Parkersburg    | Aug. 23-24-25      |
| Md., Dela. and D. C. | Easton, Md.    | Aug. 23-24-25-26   |
| Virginia             | Hampton        | Aug. 25-26-27-28   |

Kentucky's State Assn. officers, left to right foreground, 2nd Vice-Pres. W. C. Wilson, Pres. William Gresham, 1st Vice-Pres. S. J. Banahan; second row, Trustee J. P. Ratcliffe, Secy.-Treas. G. M. Rock, and 3rd Vice-Pres. J. D. Biancke.





# ROD & GUN

BY DAN HOLLAND

**Dry-fly trout fishing when the Mayflies hatch is angling at its best.**



**L**IFE IN A TROUT STREAM is a hazardous business at best, but especially so for a certain odd little creature which dwells in its depths. Constantly in danger of being devoured, he works

secretively through the thatch of green moss waving gently in the current, plows tiny trails across sheltered pockets of ooze and sediment collected out of the rush of water overhead, and squeezes into dark crevices or miniature caverns under stream-bed rocks seeking microscopic bits of food.

With two slender filaments for tails, pop eyes, a flattened body, and legs which protrude awkwardly to the sides, looking almost like a bug which has already been stepped on, he appears to be anything but a delicacy; yet he must continually be cautious and alert. Carnivorous insects, such as water beetles and immature dragon flies, search him out and prey on him; in the shallows he becomes food for a sandpiper or water ousel; and if he floats free in the current, if for a moment only, he is a goner, for this strange little insect is a favorite food of trout. He is the Mayfly nymph.

For the Mayfly nymph, life has but two dimensions: search for food and self preservation. He has no other concern.

Consequently, he lives his stream-bottom existence in seclusion—in the muck and slime, under rotting logs and water-soaked leaves, and in the semi-darkness beneath the jumble of rocks and gravel on the bottom. Then, suddenly, one summer evening, a strange and powerful impulse comes over him. With complete abandon he leaves the haven of his dark home in the stream-bottom debris and rises through the clear water to the surface. As if by some mysterious signal, thousands of others like him do likewise: forsake their shadowy depths and float carelessly to the top, oblivious to danger. Each remains there momentarily; then, as his shell-like skin splits down the back, he emerges as a delicate and graceful Mayfly, complete with gossamer wings, gently curving body and long sweeping tails.

**A**S the husk of the nymph floats away, the mature fly—so dainty that his feet make only tiny dents in the surface of the water—rests for a few moments, his thin wings held erect over his body like the sails of a miniature ship. He floats until dry; then, as though his shackles had been shed, rises gracefully into the summer twilight for one brief moment of glory, to fly and swarm with his fellows, to mate and spawn, and shortly to fall exhausted to the water, wings outspread, its life spent. This is the dance of the Mayflies.

There are hundreds of species of Mayflies. Many live in the rush and tumble of trout streams, others in the quiet waters of pond or lake. All of them are alike in general appearance, but they vary in size, color and pattern. And each species is governed by a very definite and individual cycle of life. Many of them hatch, spawn and die the same evening; other species hatch one evening, dance and die the next; but for all it is a brief and crowded moment of life.

This is a significant event not only for the insects, but for trout fishermen. When the Mayflies commence to hatch, all the trout in the stream go on a feeding rampage. They take the rising and floating nymphs, the newly-emerged flies, the dabbling females depositing their eggs, and finally the spent flies. And when the trout are concentrating on one form or another of this feast, no other food can tempt them.

Until a trout fisherman has witnessed this phenomenon, has had the satisfaction of matching the Mayfly hatch and successfully taking trout on a floating fly, he hardly knows what trout fishing is all about. Still there are a great many who have never realized the thrill and satisfaction of this experience.

This is July, midsummer, the doldrums for all such uninitiated fishermen. Streams are low and clear; trout are shy and unresponsive to bait, spinners, streamers

*(Continued on page 39)*



Trout grow surprisingly large in some deep cut-bank stretches such as this one that Dan Holland is fishing.



NELSON FOX, CHICAGO WHITE SOX, DISCOVERS WHY

# VICEROYS *are Smoother!*



"If it's smoother taste you want, try these Viceroy's of mine," says "Nellie" Fox, White Sox ace 2nd baseman. "That Viceroy taste is really smooth—beats any brand I've ever smoked."

Here's why Nelson Fox finds Viceroy's are smoother: Only Viceroy has 20,000 filters in every tip . . . twice as many filters as the other two leading filter brands. Viceroy gives you the most filters for the smoothest taste!



## *Twice As Many Filters*

in every Viceroy tip as the other two largest-selling filter brands



VICEROY'S EXCLUSIVE FILTER IS MADE FROM PURE CELLULOSE—SOFT, SNOW-WHITE, NATURAL!



# Official **ELK** Jewelry

## Honor an **ELK**



**No. 1**—50-year emblem. Beautiful, 10k gold with gold plated post and attaching button and five single cut sparkling 2-point genuine diamonds.  
Price \$78.85. A splendid gift to honored members or officers.

**No. 1A**—Same design, set with five blue sapphires. \$19.25.

You pay tribute to his taste as well as his pride in the Order when you give an Elk this handsome emblem jewelry. For each piece—from the simple membership pin to the diamond-studded 50 year emblem—is so expertly crafted, it adds lustre to the beauty and dignity of our insignia.

As a fitting reward to a veteran Elk . . . a lasting and meaningful all-occasion gift to a family member or friend . . . and of course, if you are an Elk, for your own lapel . . . this is jewelry to give or wear with pride and pleasure.

In addition to the pins illustrated except No. 3 there are others of the same designs containing either diamonds or blue sapphires which further enrich the beauty of these pins. If interested in any of the pins shown, use the coupon below. If you want details about the jeweled varieties drop us a line and we'll be glad to quote prices and furnish detailed descriptions. Please note that all retail sales must be accompanied by cash, money order or check.

**Registered designs of the B. P. O. E.  
TM and © applied for.**

**Delivery of merchandise can  
be expected within two weeks  
from receipt of order.**



**No. 7**—Membership pin without years designation. 10k gold, gold plated post and attaching button. \$7.35.



**No. 3**—25-year membership, plain (no jewels) 10k gold with gold plated post and attaching button. Handsomely enameled red, white and blue. \$8.25.



**No. 2**—Plain 50-year membership pin with no jewel but brilliantly enameled red white and blue. 10k gold with gold plated post and attaching button. \$11.00.



**No. 10**—30-year membership, plain with no jewels. 10k gold with gold plated post and attaching button. \$8.25.



**No. 9**—Life membership pin. 10k gold, gold plated post and attaching button. \$9.15.



**No. 11**—Past Exalted Ruler pin. An emblem of rare beauty designed especially for one who has distinguished himself in his lodge and among his Brother members. Same craftsmanship that makes Elk official pins such fine examples of jeweler's art. \$12.50.

**THE ELKS MAGAZINE** 386 Fourth Avenue, New York 16, N. Y.  
OFFICIAL EMBLEM DEPT.

Enclosed is check for \$.....for emblem

Button No.....Quantity.....

Name.....

Street.....

City.....State.....

On N. Y. C. orders please add 3% Sales Tax.





## Your Service Commission Answers Another Government Call

Your CD emblem, and the Fireball of May 21 test over Bikini Atoll

**P**RESIDENT EISENHOWER has approved the designation of September 9th through the 15th, 1956, as our first Civilian Defense Week. Its purpose is to pay tribute to the CD workers and organizations for their efforts in behalf of our nation. More important, however, is the opportunity provided to promote public interest in, and understanding of, a means of protecting our people, safeguarding our freedom and constructing an enduring peace.

Mr. Val Peterson, Administrator of Civilian Defense, has requested the cooperation of the Order of Elks, through the Elks National Service Commission, in attaining the goal of proper observance of Civil Defense Week in every community. As one of America's leading patriotic organizations, we have pledged our assistance.

### Accept the Training

In a special report to us, Lewis E. Berry, Jr., Deputy Administrator of the Federal Civil Defense Administration, said, "Our people, if trained properly, can defend themselves in the moment of actual crisis. However, they must be trained, and to accept that training they must have leadership and an example to follow. Our fraternal organizations can help provide this leadership and example for their communities.

"We must recognize the hard fact that without Civil Defense we cannot exist peacefully," Mr. Berry continues. "Fraternal organizations can be of invaluable assistance in Civil Defense. Many members will have the time to participate actively in the highly important jobs of operational Civil Defense. They can become block wardens, auxiliary firemen, policemen or rescue squad members. In this way they can set the examples for their communities. Other members may not be able to take such an active role, but in their everyday business affairs they can provide much of the leadership from which will stem the community incentive to do something about the problem we face. Their thinking will precede

and encourage the action we must have to make Civil Defense workable at all levels of our society.

"We are in this together. The industrialist and laborer, the housewife and the school pupil all have their particular measure of responsibility," Mr. Berry reminds us. "In recent years we have seen many of our factories and business houses, our homes and our schools dealt crippling blows by flood, fire, tornado and hurricane. Preparedness against these natural disasters to the best of our ability is Civil Defense in action.

### Air Your Opinions

"By such preparedness we strengthen our chances of survival against any threat to our life, liberty and happiness. Let your thoughts on Civil Defense be known in your community. Perhaps you will take issue with some of our concepts and applications. That is your prerogative,

but let your opinions be aired for all to hear and understand.

"Only in that way can we bring Civil Defense to all our people. Only in that way can we be assured of making it an American Plan for Survival."

Civil Defense is a positive force for peace. Its importance was clearly emphasized by President Eisenhower when he pointed out that "the task of Civil Defense is vital to our national life. It demands preparedness that can do more than limit the damage of wartime disaster. It means developing a preparedness, a vigilance so impressive as to deter aggression itself. This awareness must touch every community, every citizen . . ."

By helping to make National Civil Defense Week an overwhelming success, Elksdom will have aided in creating that awareness. We will have faced up to the Communist threat and will have contributed to the effort of preventing an attack.



A scene in a Federal Civilian Defense emergency operations room during "Operation Alert, 1955". The 1956 nationwide CD drill occurs this month, with July 20th, opening day, having a 15-minute blackout of all radio and TV programs for coast-to-coast emergency CD broadcasts.





More than 225 outstanding young men and women of the State joined with the Maine Elks Assn. and the 15 Maine lodges which participated in the 1st Annual State Elks Youth Congress at Augusta's House of Representatives. The group pictured includes sports stars, valedictorians,

salutatorians, President of the Maine Student Council Assn., the State's Cherry Blossom Queen and top junior citizens, together with the 125 Maine Elks who, with this exemplary tribute to youth, captured the first award for observances handled by State Associations.

**T**HE sixth annual observance of May 1st as Elks National Youth Day was an extraordinary success—not only from the standpoint of our young people, but also in consideration of the thought, time and effort put into these programs by their sponsors.

Grand Exalted Ruler John L. Walker's request that we "honor our youth for their accomplishments as Junior Citizens", was heeded and acted upon by Elks in every corner of our Nation. From coast to coast, carefully planned and illustrated reports came in to the Grand Lodge Youth Activities Committee for judging. The results of the Committee's consideration of these brochures are given here, in accordance with the customary

division of lodges into three categories, with three awards for each.

For lodges of more than 1,000 members the Committee gave top honors to the four-day Kelso, Wash., observance consisting of five events which served 4,200 young people and took 666 man-hours to produce. The program was launched with a two-mile long parade on Saturday, April 28th, with 33 mobile and marching units, in addition to a Kiddies' section, in which prizes were awarded for costumes and decorated bicycles. About 5,000 persons witnessed the colorful procession of 2,000 youngsters, floats and musical contingents led by an Army Reserve color guard. Sunday was designated as Youth Church Day by these

Elks who urged the young people of Kelso to make a special effort to attend their church services. On Monday, a Variety Show was put on at the lodge home in which 75 youngsters participated in 18 specialty acts.

### A Tuesday Triple

A triple event for Tuesday, Elks National Youth Day, included a special assembly at the high school auditorium, attended by every student of the school and representatives from the other four school districts within lodge jurisdiction. Chairman Edwin J. Alexander of the Grand Lodge Committee on Lodge Activities was the principal speaker at this outstanding program, during which Est.



Newport, R. I., Lodge's top-flight program won for that branch of the Order the second-place award given by the Grand Lodge Youth Activities Committee for lodges of between 500 and 1,000 members. It included the turning over of the city to students of Newport's three high schools, and took in all phases of city administration and management, including public safety. Photographed in one of the police control cars are the young student official and his experienced advisor.



Inge Schirmer, a German girl who arrived in the United States a year ago as an Exchange Student, receives the trophy signifying the first award in the Essay Contest on "The American Way of Life—Youth's Contribution", sponsored by San Mateo, Calif., Lodge as part of its Group I third-prize-winning Salute to Youth. E.R. Harold E. Anderson presents the award as Joe Ruetz, assistant football coach at Stanford University, the program's principal speaker, looks on.



# They made May Day American



Photographed during St. Paul, Minn., Lodge's third-prize-winning program for Group II are Gov. Orville L. Freeman, center, Youth Activities Chairman Robert M. Worthington, background, and top awards winners in the lodge's Scholarship and Youth Leadership Contests, left to right, Gary J. Brooten, Tom Wahman, Crystal Gray and Therese Travis.

Loyal Knight Joe Trembly presented Kelso Lodge's Youth Leadership and scholarship awards. Later, a track meet and baseball game were enjoyed by hundreds of youngsters. That evening a dance was held for about 300 teen-age couples who danced to the music of a local Youth Orchestra composed of high school and junior college students. General Chairmen Al Oldham and Velmer Backstrom and the many Kelso Elks who assisted them deserve a great deal of credit.

Second-place honors in this group went to Longview, Wash., Lodge whose observance was one in which student government of the community was the major interest. Planned months in advance, with high school students selected by their peers at a special election, the program had full cooperation of school and civic officials. During April, the elected and appointed youngsters attended civic meetings and visited various offices of the city, reporting on their findings to their fellow students. On April 30th, a banquet honored the students and their elder counterparts, with all student officials receiving gifts and certificates.

## Student Rule

On May 1st, the young people took over complete control of the city and on the 10th, the Student City Council took over the regular council meeting.

This program, for which Frank Wean, Robert Bailey and Bill Eddy were Co-Chairmen, also saw several editorial positions on *The Daily News* taken over by young people, as well as key posts at radio station KWLK.

San Mateo, Calif., Elksdom captured the third award in this category for a repetition of its fine 1955 program—a county-wide essay contest on "The American Way of Life—Youth's Contribution". All elementary and high schools, both public and parochial, were invited to par-



A sideline view of the "Y" pool before the start of the exciting swimming meet which was part of Auburn, N. Y., Lodge's observance, first-prize winner for lodge's of 500 to 1,000 members.



Rocky Mount, N. C., Lodge's Tribute to Youth which won third-place honors for Group III included a big Track Meet for junior high school students who competed in various races. One of these contests was a basketball dribble race, the start of which is pictured here.





Above are some of the 50 young racing enthusiasts who competed in Fulton, N. Y., Lodge's Annual Soap Box Derby, part of its Group III, first-prize Youth Day program.

Below: Longview, Wash., Mayor H. R. Nichols watches over student Mayor Steve Hedrick as he works out a problem in civic government during the local Elks' Youth Day program which won second prize in Group I.



ticipate, and nearly every school accepted, with the lodge receiving over 100 essays for final judging, following the first selection, made by the principal of each participating school. The students, from the fifth grade through junior and senior high school classes, were divided into four groups. It is interesting to note that the winner of the Senior-Junior Group I was Inge Schirmer, a German girl in this country for a year's study under the Exchange Student Program sponsored by the American Field Service.

Trophies and \$550 in Bonds were awarded, with the first- and second-place winners in each group rewarded at a special May Day program when the winning compositions were read by their authors and the judges, a group of outstanding citizens well versed in the problems and interests of our young people, were introduced. Youth Chairman Donald J. Miller opened this ceremony, with E.R. Harold Anderson speaking in welcome.

Honorable Mention in this Group went to Binghamton, N. Y., Muskegon, Mich., Phoenix, Ariz., Puyallup, Wash., Richmond, Calif., and Seattle, Wash., Lodges.

Auburn, N. Y., Lodge put on a week-long program which captured first place for lodges of between 500 and 1,000 mem-

bers. Climaxed by a spectacular parade composed of six divisions which led to Seward Park where special ceremonies were conducted at the monument of William H. Seward, the program was first planned in February by a group of Elk and school officials. The discussion panel included State Vice-Pres, Philip J. Conboy, Committee Chairman, and Supt. of Schools Dr. C. G. Hetherington. As a result of this cooperative effort at planning, the observance was an unqualified success. Opening on April 25th with a Poster Contest on "What America Means to Me" when art work was offered by students from the 7th to 12th grades and displayed in shop windows throughout Auburn, the event found students handling city and county government followed by a Teen-Agers dance at the lodge home on the evening of the 27th.

On Saturday, the YMCA pool was turned over to the Elks for a boys' and girls' swim meet in which 100 youngsters in three age groups competed. Special religious services were held at the community's churches on Sunday, and on Monday, April 30th, the East High School Auditorium was the scene of a highly enjoyable Talent Show, participated in by youngsters from all over the county.

The evening parade and program at Seward Park found local Youth Leaders rewarded and City Mgr. George F. Train as principal speaker.

### Experience Counts

As six-time Youth Activities champion for Rhode Island, Newport Lodge had plenty of experience in working with our young people, as evidenced by the fact that its Youth Day event won second place in Group II. This program began April 28th with students from three secondary schools taking over the operation of the county's only radio station. Under the direction of the lodge's Youth Committee and WADK personnel, the students performed creditably as newscasters, disc-jockeys, technicians. On Sunday, an Elks Scout Fellowship breakfast was served to 85 representatives of Boy and Girl Scout Troops, when J. H. Williams, State Commissioner of Scouting, was the principal speaker. Elkheart Air Squadron #1, an Explorer Scout group sponsored by the lodge, was host unit, and breakfast was prepared by members of Newport Elkdom.

That afternoon, a giant Scout-O-Rama was held on the grounds of the lodge

(Continued on page 27)



San Benito, Tex., Lodge's second-place event for lodges of less than 500 members, included not only City Government for Students, but the manning of the city's police and fire apparatus, as you see.



Kelso, Wash., Lodge, which took first prize for lodges of more than 1,000 members, had this photograph taken during the Variety Show for youngsters who had won other Elk contests in the State.



*A Message  
from the  
Grand Exalted Ruler*



**P L A N   E L K D O M ' S   P R O G R E S S**

**A**S MY ADMINISTRATION comes to a close with our Convention in Chicago, this will be my last opportunity to address you through the pages of *The Elks Magazine*, a privilege I have enjoyed during the year.

I shall always be most grateful for the wonderful opportunity you gave me to serve Elkdom as the chief executive of our great Order. You have overwhelmed me with your cordial hospitality, which is genuinely appreciated. I shall always treasure the many friendships I have made. You made it possible for me to visit Lodges in each of our 48 states and the District of Columbia, and to observe first-hand the marvelous work the Elks are doing everywhere for the less fortunate. Never have I been so proud of our beloved Order.

For the 17th consecutive year our Order has shown a substantial net increase in membership. On March 31, 1956, we had 1,173,494 members, a net gain of 23,881 for the year. It is significant that this increase in membership came despite a most vigorous cleaning up of our membership rolls through the dropping of members for nonpayment of dues. The Elks National Foundation had the best year that it has ever had. It took in \$403,802.17 during its fiscal year and more importantly, the number of individuals who made contributions this year was the largest of record. Our Youth Activities programs have been expanded. The Lodges and State Associations have enlarged their charitable and community welfare work. We are furnishing recreation and entertainment to the war

victims in our Veterans' Hospitals and to those in our Armed Forces.

We have had another successful year because of the wonderful cooperation of each of you. I shall never forget your loyalty, your faithfulness to duty, and the outstanding support you gave my administration and me.

I want to thank the Past Grand Exalted Rulers, Grand Lodge Officers, Commissions and Committees, District Deputies, State Association Officers and Committees, Subordinate Lodge Officers and Committees, and my Brother Elks, for contributing so much to the success of my administration. I genuinely appreciate the splendid cooperation that I have received from each of you.

It is impossible to over-emphasize the important part played by our Past Grand Exalted Rulers in making the Order of Elks what it is today. Our Order has continued to grow and prosper because its distinguished leaders constantly and effectively devote their time and talents to it. I shall always be most appreciative of the helpful counsel and whole-hearted cooperation they have given me this year.

It is my sincere wish and prayer that Almighty God will always bless you and that our Order will continue to grow and prosper, and it will do so as long as we are true to the cardinal principles of Charity, Justice, Brotherly Love, and Fidelity. Faithfulness to those principles will make all of us better Elks and better Americans and will make each of us more determined than ever to

**"SERVE ELKDOM—LIVE ELKDOM"**

*John L. Walker*  
GRAND EXALTED RULER



## ELKS LODGE ACCOMMODATIONS

WE HAVE HAD so many requests for an Elks Lodge accommodation list that we plan to publish portions of the list from time to time in our travel columns. This fourth installment will be followed, as space permits, in later issues, until the entire list is published.

Following the complete publication, we plan to incorporate all this information in a pocket-sized booklet for our traveling readers. If your lodge is not listed, it means we have received no answer to our request for information sent out last May.

### CANAL ZONE

CRISTOBAL *Breakfast-Lunch-Dinner  
Cocktail Lounge*

### COLORADO

ALAMOSA *Rooms, Elks & Male & Female  
Guests, Cocktail Lounge*

ASPEN *No Accommodations*

BOULDER *No Accommodations*

BRIGHTON *Cocktail Lounge*

CANON CITY *Cocktail Lounge*

CENTRAL CITY *Bar*

COLORADO SPRINGS *Lunch & Dinner*

*Cocktail Lounge*

CRAIG *Cocktail Lounge*

CRIPPLE CREEK *Rooms*

*Elks Cocktail Lounge*

DELTA *Cocktail Lounge*

DENVER *Lunch, Cocktail Lounge*

DURANGO *Cocktail Lounge*

FT. COLLINS *Lunch*

FT. MORGAN *Bar*

GRAND JUNCTION *Cocktail Lounge*

GREELEY *No Accommodations*

GUNNISON *Bar & Cocktail Lounge*

IDAHO SPRINGS *Bar*

LA JUNTA *Rooms (Elks & Male & Female*

*Guests) Breakfast, Lunch, Dinner*

*Cocktail Lounge*

LAKESWOOD *Cocktail Lounge*

LAMAR *No Accommodations*

LEADVILLE *Cocktail Lounge*

LOVELAND *Cocktail Lounge*

MONTROSE *Cocktail Lounge*

OURAY *Cocktail Lounge*

PUEBLO *Lunch, Bar*

ROCKY FORD *Bar*

SALIDA *Cocktail Lounge*

STERLING *Cocktail Lounge*

TELLURIDE *Cocktail Lounge*

TRINIDAD *Cocktail Lounge*

VICTOR *Cocktail Lounge*

WALSENBURG *Cocktail Lounge*

### CONNECTICUT

ANSONIA *Cocktail Lounge*

BRIDGEPORT *Cocktail Lounge*

DANIELSON *Bar*

DERBY *Bar*

GREENWICH *Bar*

HARTFORD *Bar*

MANCHESTER *No Accommodations*

MERIDEN *Cocktail Lounge*

MIDDLETOWN *Cocktail Lounge*

MILFORD *Lunch, Dinner (Sat. Night only)*

*Cocktail Lounge*

NAUGATUCK *Lunch, Cocktail Lounge*

NEW HAVEN *Cocktail Lounge*

NEW LONDON *Cocktail Lounge*

NORWICH *Cocktail Lounge*

PUTNAM *No Accommodations*

ROCKVILLE *Cocktail Lounge*

SOUTHINGTON *Bar*

SOUTH NORWALK *Cocktail Lounge*

STAMFORD *Bar*

TORRINGTON *Cocktail Lounge*

*(Connecticut to be continued)*

## for Elks who TRAVEL

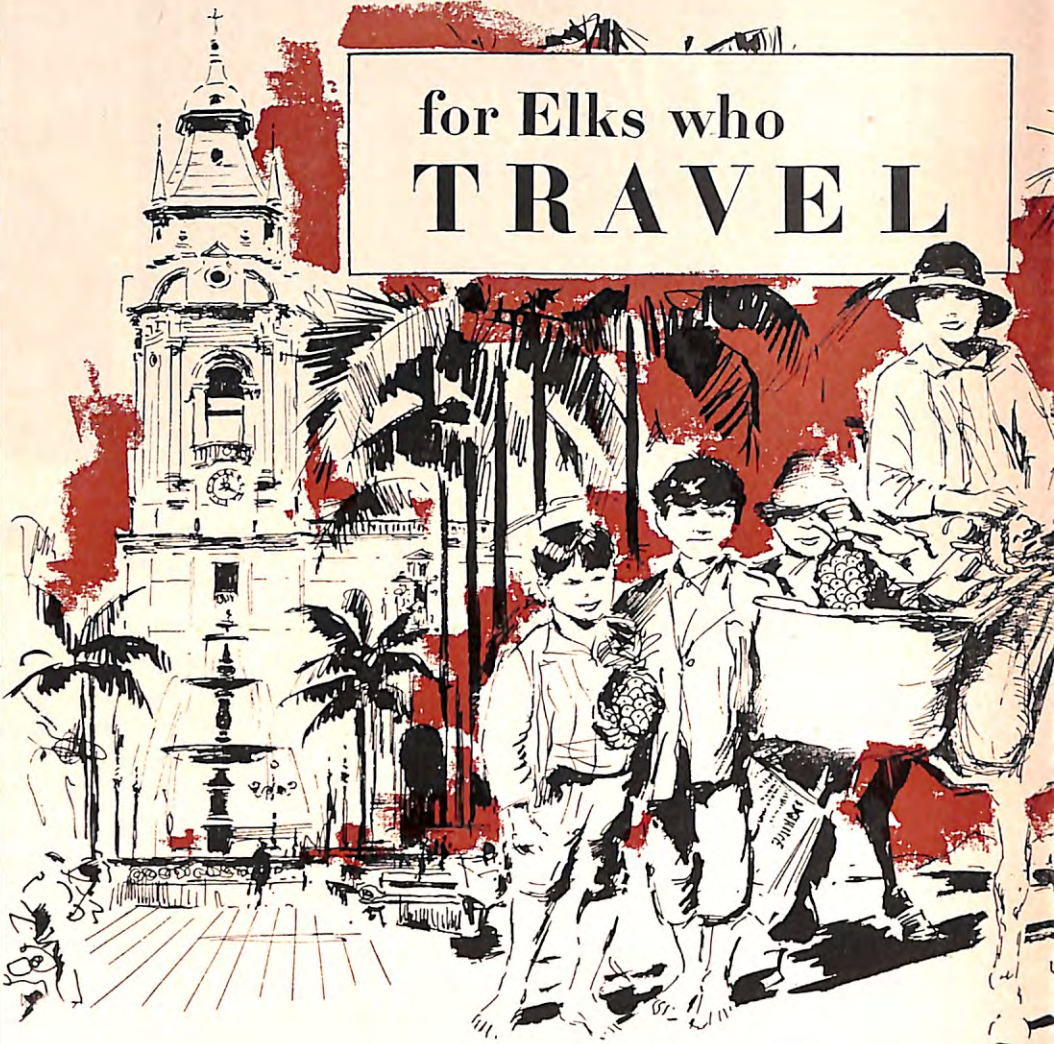

BY HORACE SUTTON

**One way to be cool this summer is to visit  
South America, where it is topcoat weather.**

FACING a purring air conditioner is only one way of staying cool in the upcoming months. Another is to pick up what other belongings and relatives seem necessary and take yourself somewhere where its winter when it's summer here.

Now that might, on the very face of it, appear to be a rather drastic move, just to avoid heat prostration, but there are other benefits to be sure. One is that you can write the folks sweltering in the mid-western midsummer and say: "Here I am in Chile, today we went skiing." I was in Chile last August and I must say the clear, crisp topcoat weather made you feel like a brisk day in the North American fall. The mountains were dappled on top like a marshmallow sundae and soldiers who came on guard duty in the streets at night appeared with blanket rolls to ward off the chill. Walking into the fashionable Carrera Hotel, which is owned now by Intercontinental Hotels, a division of Pan American Airways, it

seemed like midwinter in Paris. The ladies were all done up in black wool, and they were whiling away the short afternoons by sipping hot tea while watching a showing of fashions.

I had somehow envisioned that South America would be a prolongation of that type of sun-bleached look that one sees in Havana, in parts of Puerto Rico, and in Mexico. Perhaps that is true in the northern countries of the continent, which I have not as yet visited. The southern ones—Peru, Chile and Argentina, all seemed to me to exude an air I knew well in Europe. The broad avenues, the graceful mansions, the chic ladies were all a part of the life, I thought, of Paris, Brussels, or Madrid.

Driving out of Santiago, one morning, on the way to the ski slopes, the fields, the snow on the hills, the rows of poplars were certainly reminiscent of the landscapes of Europe. The ski resort of Farellones, on the other hand, was a



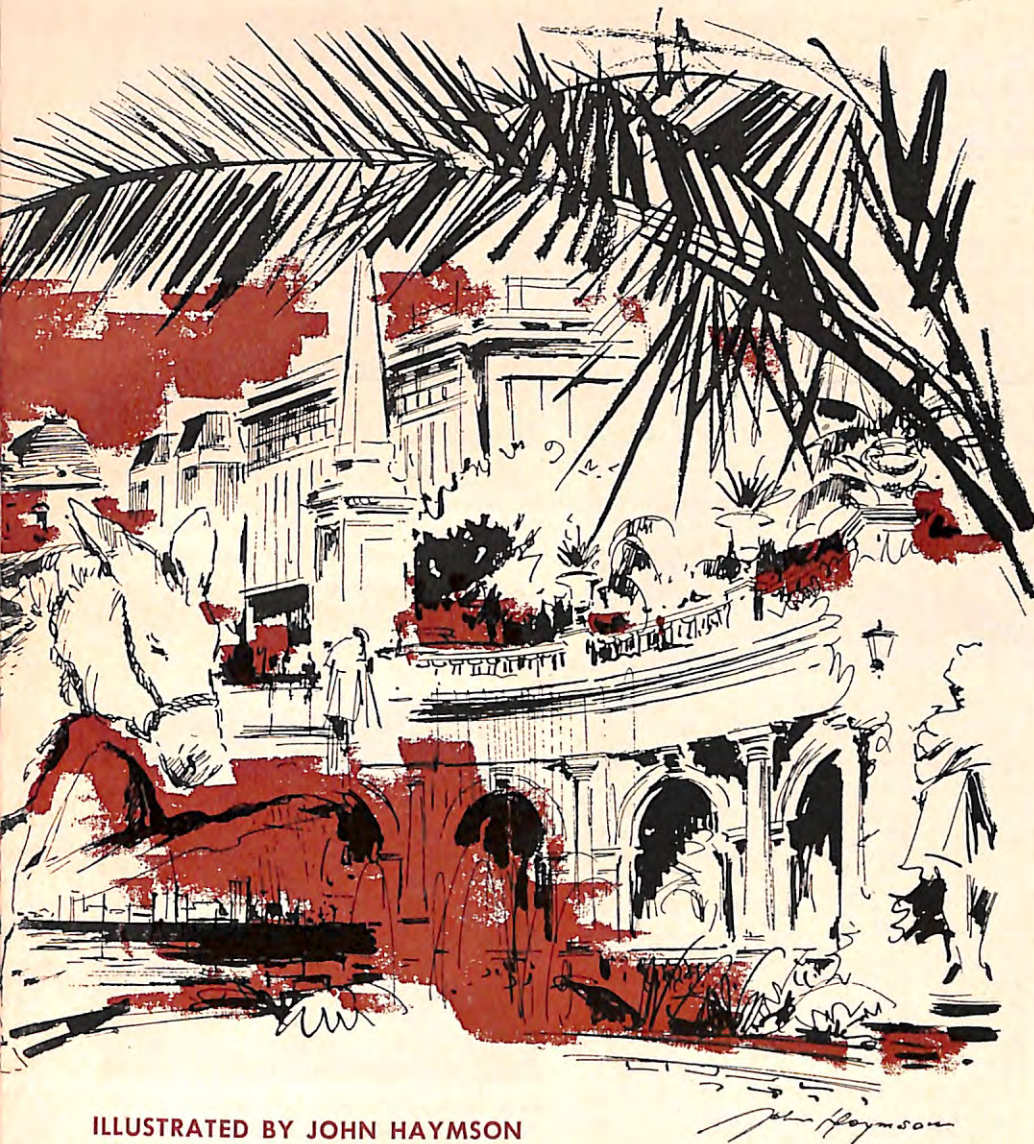

ILLUSTRATED BY JOHN HAYMSON

good deal more primitive than what you can find either at St. Moritz, St. Anton, Kitzbuehl, Sun Valley, Stowe, or you-name-it. The Chileans are not afraid of roughing it in double-decker bunks, nor of eating, friendly-like at long tables. On the other hand, the price, by our standards in the north is all but incredible—it comes to about \$1.50 a day for a bunk in the dormitory and three meals a day. The spiffiest of places at Farellones costs \$2.25 a day.

Chile does have one plush winter resort at Portillo, five hours from Santiago, a trip by railroad that will cost you \$3.50, or roughly the price of a coach ticket from New York to Philadelphia. It has 400 rooms, a French ski instructor of considerable renown, and most of the accoutrements of a first class ski resort.

As for Peru, you can whip down there in short order nowadays, aboard the DC-7 Bs of Panagra Airlines, a corporation owned jointly by Pan American Airways and the W. R. Grace Co., whose ships explore the west coast of South America. (Moore, McCormack has the east, or Atlantic coast routes.) It will take you about nine and a half hours to

bus down from Miami, smoldering in the heat of summer, to Lima, damp in the chill of winter.

There is, of course, much more that is Spanish colonial in Peru, intermingled with native Indian. It makes a fascinating combination. There are, to be sure, all manner of relics of those early Spanish days—the homes of the gay governors, the chambers of the dread Inquisition, and that holdover to this present day, the bull ring. The arena in Lima is the oldest in the New World, having been built back in the 18th Century. It is now enlarged to seat more than 17,000 Peruvians.

Shopping in Peru is interesting, inexpensive and fun. In the first place, you should have a look at Peruvian silver which is fashioned into almost any doodad you can think of—cuff links, tie pins, money clips, key rings, pill boxes and even statuettes of bulls being stuck by the lance of the picador. The other buy is llama fur and alpaca. The Peruvians do artful things with it—sewing it into mosaic type rugs with patterns of tan, brown, white and black that are ideal for

(Continued on page 44)

## RETIRE ON \$90 A MONTH

or less in a resort area, 365 days of sun a year, dry temp. 65-85°. Or maintain lux. villa, servants, ALL expenses \$150-250 a mo. Am.-Eng. colony on lake 60 mi. long. 30 min. to city of 1/2 million, medical center. Schools, arts, sports. Few hours by air. Train, bus, PAVED roads all the way. Full-time servants, maids, cooks, \$6 to \$15 a mo., filet mignon 35c lb., coffee 40c, gas 15c gal. Gin, rum, brandy 65c-85c fth., whiskey \$1.50 qt. Houses \$10 mo. up. No fog, smog, confusion, jitters. Serene living among world's most considerate people. For EXACTLY how Americans are living on \$50—\$90—\$150—\$250 a mo., Airmail \$2.00 for 110 Pages current info., prices, roads, hotels, hunting, fishing and living conditions from Am. viewpoint (Pers. Chk. OK) to Peter Arnold, S.A., Box 12, Ajijic, Lake Chapala, Jal., Mexico.

### FLORIDA Homesites \$10 down \$10 month

Highland Park Estates on beautiful 84-sq.-mile Highlands Lake in the heart of the pinelands and citrus area. Full 1/4 acre at amazingly low prices. For details, no obligation, write: Dept. E7K, FLORIDA ESTATES, INC., National Headquarters, 1029 Vermont Ave. N.W., Washington 5, D.C.



Make This Your  
Shore Line Stop Off  
when in New Jersey

### TOM'S RIVER No. 1875

Enjoy clean ocean-swept breezes and the comforts of a home-like lodge offering recreational facilities, pool, a handsome lounge with music and entertainment featured every week end. Open 3 P. M. daily, 1 P. M. 'til legal closing hour week ends. Fine restaurants and lodgings nearby and all bathing and fishing accommodations. Clubhouse showers. Convenient to N.J. Garden State Parkway, U.S. Highway No. 9 and State Highway No. 37. A warm welcome awaits you.



### FLORENCE SAYS "HOWDY"

Florence, Colorado, B. P. O. Elks No. 611 offers traveling Elks and their ladies 21 excellent rooms and comfortable surroundings. No food served but convenient restaurant facilities available. Room rates \$2 per night. Liquors served. You'll find Florence lodge a fine stopping off place where a warm welcome awaits you.



# News of the Lodges



This photograph includes current and former State Assn. officers and District Deputies who made up the Grand Lodge panel for the institution of St. Helens, Ore., Lodge, No. 1999, whose large Charter Member Class was initiated by the officers of Portland Lodge. In the foreground, left to right, are P.E.R. Marc Bowman of Portland Lodge, Chairman Frank Hise of the Grand Lodge State Assns. Committee, Special Deputy Clifton B. Mudd, Past Grand Exalted Ruler Frank J. Lonergan, D.D.'s H. M. Randall and Stewart W. Patty, former Grand Lodge Committeeman. A. W. Wagner, and P.E.R.'s W. E. Stewart, Jr., of Salem, C. H. Christensen of Tillamook and Fred Simpson of Toledo.

## 36th Annual Elks National Bowling Tourney Report

The outstanding 36th Annual Tournament of the Elks National Bowling Assn. held at Louisville, Ky., saw 2,033 prizes awarded representing a total of \$32,538. This amount was realized through the record entry of 1,161 five-man teams, 2,616 doubles and 5,232 singles.

Taking the five-men awards, which included two sponsor's trophies, a gold wrist watch and an individual trophy for each man, were the West Side Pontiac

group from Lakewood, Ohio, Lodge, actual pin-fall champions with a score of 2836. Handicap winners in this event were the Inner Guards from Newport, Ky., who won \$300, five individual trophies and a sponsor's trophy. John Salapa and John Penzelik from Homestead, Pa., Lodge, won gold watches and the two-men event, with D. Gregg and H. Green of Canonsburg, Pa., the Handicap Winners of \$150 and two individual trophies.

Joe Breit of Cleveland, Ohio, Lodge, was the actual pin-fall champion, winning a gold watch as singles champion,

with J. Henry of Gary, Ind., taking the handicap title with \$100 and a trophy. Charles J. Miller, Jr., a Marion, Ind., Elk bowler, won a gold wrist watch as All Events Champion.

During this meet, the Association presented a \$1,000 donation to the Elks National Foundation for its third Founders Certificate, and decided to hold the 37th competition in Columbus, Ohio, beginning March 2nd and running on week-ends only through May 12th.

Information regarding this Tournament may be secured from Assn. Secy. E. N. Quinn, P. O. Box 29, Madison 1, Wis.

## Chillicothe, Ohio, Elks Busy

Recent reports from Chillicothe Lodge No. 52 concern two worthwhile events—a record-breaking blood drive and an outstanding tribute to its 50-year members.

Given warm editorial praise in the local *Gazette*, the Elk-sponsored blood collection realized a total of 202 pints for the



P.E.R. William Schmeiser, left, presents Aurora, Ill., Lodge's \$1,500 check for the Valley Parent Group, at its school in Batavia, represented by Group Pres. Eric G. Thorson. The gift was a portion of the proceeds realized from the lodge's Fifth Annual Charity Dance. The \$1,000 balance was contributed to the Elks National Foundation.

A recent meeting of Richmond, Calif., Lodge honored P.E.R. A. F. Bray, a member of the Grand Lodge Committee on Judiciary. Among those on hand to see Judge Bray receive an Honorary Life Membership were Past Grand Exalted Ruler L. A. Lewis and 25 of the lodge's 27 living P.E.R.'s. Left to right foreground are D. M. Bradley, Past State Pres. C. C. Anglim, Judge Bray, Mr. Lewis, Senior P.E.R. Dr. C. L. Abbott, P.E.R. John A. Bell and L. M. Johnson.



Past Grand Exalted Ruler William J. Jernick, right, presents to E.R. Joseph M. Petty of Trenton, N. J., Lodge, left, checks totaling \$6,000 to be distributed within the lodge's jurisdiction for the relief of victims of last summer's floods. This gift is part of the \$12,500 which the Grand Lodge has donated to the State for this purpose. Looking on is State Assn. Pres. William R. Thorne.

ADDRESS OF GRAND EXALTED RULER JOHN L. WALKER: B.P.O. Elks Lodge No. 197, 602 South Jefferson St., Roanoke, Va.  
ADDRESS OF GRAND SECRETARY LEE A. DONALDSON: Elks National Memorial Building, 2750 Lake View Ave., Chicago 14, Ill.





A successful \$275,000 drive was concluded recently in Meriden, Conn., for a new Boys Club. This photograph commemorates the presentation of Meriden Lodge's \$13,000 check for this project by E.R. John J. Ward, right, to Elk Charles Gearing III, General Chairman of the drive. Looking on at left is Past District Deputy Charles L. O'Brien.



Representatives of North Platte, Neb., Lodge and their ladies sign pledges totaling \$1,000 for a memorial pediatrics room at the new Memorial Hospital. Left to right are Mrs. Marie Calhoun of the Elks' ladies who pledged \$300; E. H. Shoemaker, Jr., Pres. of the Hospital's Advisory Board, and E.R. F. W. Voseipka of the lodge which pledged \$700.

Red Cross whose Recruitment Chairman, G. R. Williams, expressed himself as being highly pleased with the results of this, the area's first organization-promoted drive.

Elks were on hand to present 250 TV stamps to each donor with the compliments of Kroger's, a local shop. E.R. H. E. Grady had only one disappointment during the day; he himself was rejected as a donor because of too brief an interval since his last donation.

Chillicothe Elksdom saluted its 50-year members and officers of former years at a dinner-meeting when Mr. Grady presented scrolls to 55-year Elks W. R. Lowrey; 54-year Elk Albert Schlegel, 53-year-Elk Clyde Athey, 52-year member W. H. Howson, and 51-year affiliates C. H. Duncan and A. E. Herrnstein. Absentee half-century members included Charles Schlegel, Ward Carson, Dr. Ernest Schwarzel and G. C. Foster.

P.E.R.'s opened and closed the session which followed a baked ham dinner attended by 100 persons. It was announced at that time that the lodge's P.E.R.'s Assn.'s 1956 objective, the purchase of a new station wagon for the Salvation Army, would be realized. W. R. Kramer, Pres. of the group, reported that the



Past Grand Exalted Ruler Charles E. Broughton, right, with Past Grand Tiler Otto B. Stielow, left foreground, and E.R. Don H. Verhulst, turned the first shovelful of ground for the erection of Sheboygan, Wis., Lodge's \$200,000 home. In the background are officers and members.

necessary funds had been raised to order a Chevrolet station wagon for the Army.

### Texarkana, Ark., Elks Initiate Fort Smith Class

When the Arkansas Elks Assn. met at Fort Smith in May of last year, E.R. George Shaw of Texarkana Lodge promised E.R. Scott Emerson of the host lodge that Texarkana officials would be happy to return to Fort Smith to initiate a class

there. That promise was kept on April 15th, when a class of ten was initiated by the very capable Ritualistic Team from Texarkana, headed by Mr. Shaw. P.E.R. Emerson named the class in honor of Grand Exalted Ruler John L. Walker. Visitors on hand for the memorable ceremony were D.D. Victor H. Wilder and P.E.R. Hugh Martin of North Little Rock, George Rector, Jr., and Anthony Grove of Mena, and Tom Lemon of Marietta, Ga.

Beloit, Wis., Lodge officially acquires the former headquarters of the Wisconsin Telephone Company for its new home. Seated at right, E.R. Milo Wardlow presents a \$60,000 check to the firm's Milwaukee attorney C. F. Krizek, completing the purchase. Looking on, left to right, are Beloit Co. Mgr. E. R. McGinnis, D.D. Dr. Austin F. Sipple, lodge Trustee, and General Chairman and Trustee I. E. Myrland, P.E.R.

A new Chevrolet station wagon is presented to the Salvation Army by the P.E.R.'s Assn. of Chillicothe, Ohio, Lodge. Pictured with the car are, left to right, P.E.R.'s C. J. Wachter, lodge Secy., C. E. Rodehaver, C. R. Cline and H. E. Grady, E.R. E. K. Foster, P.E.R.'s E. R. Miller and V. R. Barrett, Trustee of the Army, Capt. Levi Olmstead of the Army's Ross County Chapter and Club Manager H. E. Moore.





# NEWS of the LODGES



This photograph, taken at the dedication of the handsome new building given by the Elks of Mesa, Ariz., to the Boy Scouts, includes Elk officials and Scouts, with Scoutmaster Guy Nicoll, guest speaker Frank Popello and E.R. Joseph A. Stephens. All material and labor for the \$5,000 building, judged to be one of the finest in the State, were donated by members of the lodge.



Above: When the first Easter Sunrise Service was held at Casa Grande Mountain Park, the Elks of Casa Grande Valley, Ariz., Lodge provided this American Flag for the occasion. This photograph which so closely resembles the famous Iwo Jima flag-raising picture, was snapped as the banner was raised by Kenneth, left, and Vernon Hayes, right, brothers of Ira Hayes who was one of the men in the Iwo Jima photograph. Assisting the Hayes brothers in this duty is Robert Walker.



Above: Auburn, Wash., Lodge welcomed a class of 85 candidates as a tribute to its retiring E.R. Robert Gaines. Photographed in the first row, fifth, sixth and seventh from left, respectively are D.D. Ronald C. Gosselin, Chairman Edwin J. Alexander of the Grand Lodge Committee on Lodge Activities and E.R. Gaines.



Charles B. Ellison, Jr. P.E.R., left, of Lancaster, Calif., Lodge is congratulated by D.D. C. Wallace Ericson on the night Lancaster Elksdom attained its 100 per cent paid-up membership.

Below, right: E.R. Jack Harris breaks ground for the home of Bishop, Calif., Elksdom which is expected to be completed in the Fall. Others pictured are, left to right, foreground, Secy. L. G. Hummel, Inner Guard Earl Kiefer, architect and Elk Allan O'Connor, P.E.R. C. J. Harlin, Chairman of the Building Committee, Committeeman and P.E.R. H. C. McAfee, Trustees Chairman Howard Wentworth and Trustee Jack Rhoads. In the background are P.E.R.'s, other officers and interested members.

## John Baker of Hood River, Ore., Honored

When John Baker received a jeweled 50-year-membership pin on Old Timers Night at Hood River Lodge No. 1507 last year, it did not indicate merely a 50-year affiliation with Elksdom. John Baker has been an Elk since 1892 when he joined Findlay, Ohio, Lodge. In 1918 he transferred his membership to The Dalles, Ore., Lodge, and in 1925 he became a Charter Member of No. 1507. Always a devoted Elk, he served as Chairman of his lodge's Sick Committee for 25 years. In 1930, in recognition of his fine efforts for the Order, he was awarded an Honorary Life Membership.

Mr. Baker is now 92 years old and still active, making daily visits to his law office and his lodge home.

Below: Victor Zednick, third from left, retiring after 31 years as Secy. of Seattle, Wash., Lodge, accepts an Honorary Life Membership and plaque from Chairman Edwin J. Alexander of the Grand Lodge Committee on Lodge Activities, second from left, at a dinner-meeting in Mr. Zednick's honor when 75 men were initiated. At left is Past State Pres. Arthur Ochsner, and at right is E.R. Cliff Whittle.







With E.R. Frank Garland, State Assn. Pres. William Singer and Est. Lead. Knight Charlie Ward standing behind them are, left to right, Alan Schwiesow, his father, John, Sr., John, Jr., and Earl, when Alan and Earl joined their family as members of Centralia, Wash., Lodge.



When Pres. Dante Vaio of the N. M. Elks Assn. paid his official visit to Farmington Lodge a class of 36 was initiated in his honor, among them the two sons of E.R. Jim Carpenter. Pictured here, left to right, are David Carpenter, E.R. Carpenter, Danny Carpenter and Mr. Vaio.



When State Pres. Jim B. Nielsen visited Pittsburg, Calif., Lodge he presented to Miss Betty Renee Hunt a \$200 scholarship award. Left to right are State Vice-Pres. Charles Aiman, Mr. Nielsen, E.R. D. F. McMullen, Miss Hunt, lodge Secy. Harold DeFraga, Miss Hunt's sister, D.D. G. F. McCormick and the young lady's mother.

Over 350 Elks participated in Walla Walla, Wash., Lodge's tribute to Louis B. Romine, seated, on the occasion of his 30th installation as Secy. Among them were P.D.D. L. L. Barrett, Past State Pres., left; E.R. G. S. Weathers, Jr., center, and retiring E.R. J. O. Huntington.



### Fairbanks, Alaska, Lodge Welcomes 50 Candidates

As the result of a concentrated effort to cooperate toward the Grand Exalted Ruler's goal of a five per-cent membership increase, Fairbanks Lodge No. 1551 added 50 names to its roster. During February, 82 applications for membership were signed, and the 50-man group initiated early in March was the largest class to become affiliated with the lodge in 20 years, according to retiring E.R. E. P. McCarron.

For the occasion, E.R. Richard Smith and the officers of Anchorage Lodge, together with 14 of its P.E.R.'s, chartered a plane for the 550-mile trip to Fairbanks to perform the ceremony. Grand Tiler M. E. Monagle of Juneau, who had been in San Francisco on a law case before the Circuit Court of Appeals, flew up from the Bay City for this event. The outstanding class which included many business and professional men, among them Judge Vernon D. Forbes, brought the lodge's membership to 1,100.

### News of Myrtle Beach, S. C., Lodge

At a recent meeting of Myrtle Beach Lodge No. 1771, retiring Chairman Don Moore of the lodge's Scholarship Committee announced that \$250 scholarship awards had been made to Edward Moore and Miss Nancy Hitchcock.

Acting E.R. Carlisle Taylor presided, introducing to the membership the lodge's first E.R. Charter Member Fred Wiley. Another item of business was the authorization of a \$50 donation to the Horry County Rescue Unit.



This photograph, which includes all lodge officers and all but one of the Trustees of Sacramento, Calif., Elksdom, was taken when retiring E.R. Frank A. Lagomarsino, center foreground, was honored with the initiation of a class of 27. On Mr. Lagomarsino's left is 47-year-Elk Harry Robertson and, on his right, Alexander Crossan, both of whom received

Honorary Life Memberships that evening. Incidentally, Mr. Crossan, who is editor of the lodge's very fine bulletin "Number Six", has presented a copy of "The History of the Order" of Elks to a member of every class which has been initiated into Sacramento Lodge since the beginning of the 1954-55 subordinate lodge year.





When Herkimer, N. Y., Lodge's Youth Center was opened recently, Trustees Chairman Eugene Cress turned over its keys to the Center's Co-Chairmen Saul Myers and Frank Wiederman. Left to right are State Vice-Pres. William M. Hiller, E.R. John S. Hadala, Mr. Myers, Mr. Cress, Mr. Wiederman, and John B. Hanlon, Chairman of the New Jersey State Elks Youth Activities Committee.

Below, right: For 20 years, Sioux Falls, S. D., Lodge has conducted an "All State Night" on the second meeting night in March, when chairs are filled by P.D.D.'s from the State's 12 lodges. An inspired speaker this year was Past Grand Exalted Ruler James G. McFarland, seated first row, center, with the class initiated that evening, and, standing, lodge officers and other dignitaries.



The Ohio Elks Assn.'s Cerebral Palsy Training Board gives a \$2,000 check to the Lancaster-Fairfield County United Cerebral Palsy Assn. following its receipt of Lancaster Lodge's notice of the Assn.'s need. Left to right are lodge Secy. Leo E. Ward, United C/P Assn. Vice-Pres. Leo DeMastry, P.E.R. James W. Mills, Esq. E. E. Allison, E.R. Martin H. Hettinger, Assn. Vice-Pres. Clark McGhee, Est. Lead. Knight James Eggert, Elk John Bauman and Miss Margaret Bauman, Pres. of the recipient group.

## NEWS of the LODGES



During the first days of the 1956 Elks National Bowling Assn. Tournament in Louisville, Ky., Grand Exalted Ruler John L. Walker was present to receive a \$1,000 check for the Elks National Foundation from the nation's Elk bowlers. Pictured at the opening, left to right, are Pres. Larry Staubach of the Ky. Elks Assn.; local Tournament Chairman Joseph Kramer; local Committeeman Rand Wells; Pres. H. M. Lampert of the Elks National Bowling Assn.; host, E.R. M. M. Hellman; Assn. Secy. Edgar N. Quinn and 1st Vice-Pres. R. D. Bonnell; J. Edward Sihal of the Grand Lodge State Associations Committee, and local Tournament Co-Chairman Jack Steffen.



During the Birmingham, Ala., March of Dimes drive, the local Elks sponsored the visit of Lili Gentle, 20th Century-Fox starlet to participate in the local TV telethon. A Birmingham girl, Miss Gentle was welcomed at the airport by Elk officials, the lodge's Youth Band and city and campaign officials. Left to right foreground are lodge Trustee Max Scholder, Chairman Russ Morgan of the March of Dimes, Miss Gentle, retiring E.R. Dr. Mauro J. Nappi; second row, lodge Secy. H. W. Gilmer, Trustee Glen E. Messer, Youth Band Director Tom Connors, P.E.R. and Youth Activities Chairman T. D. Stephens and Dick Cavaleri, Crippled Children's Hospital Director.



### Herkimer, N. Y., Elks Establish Youth Center

When the Youth Center of Herkimer was opened by Mayor Lynn Farrell not long ago, the ceremony was the reward of three years of work on the part of the Youth Activities Committee of Herkimer Lodge No. 1439. James B. Hanlon, State Youth Activities Chairman, spoke highly of the lodge, commending its action in helping to combat juvenile delinquency by providing this recreation area for the community's young people. His address was made at a dinner preceding the opening, when committeemen, Student Councilmen from Herkimer Central School and Class Advisers were guests. He was introduced by State Assn. Vice-Pres. William Hiller.

The Center, located in the lodge's former home, vacated when it took occupancy of its \$100,000 building dedicated last October by Grand Exalted Ruler Walker, will be operated jointly by the

Elks' Committee and the Village Youth Committee, although the building itself will remain in the hands of the lodge's Board of Trustees of which Eugene Cress is Chairman.

The Center will occupy the first floor while rooms on the second floor will be maintained by the Boy Scout Troop and Cub Pack sponsored by the lodge. Peter Christiano is the Director for the Center where television, radio, phonographs, table-tennis and other games, magazines, refreshments, dancing and movies are furnished.

An additional feature is provided by Robert Watts, Herkimer flying enthusiast, who has offered to give the teenagers flying lessons through the Center, at the cost of the gasoline and oil used.

A fund of \$1,264 is available for the Center's operation on a six-month trial. It will be open from 7 p.m. to 10 p.m. Monday through Thursday, and from 7 p.m. to 11 p.m. on Friday and Saturday.

This compelling sign was presented to the local Boy Scout Council by Charleston, W. Va., Lodge and is displayed on a triangle fronting downtown Charleston's main street with the neon-illuminated legend flashing on and off 24 hours a day. Inspecting the sign are, left to right, lodge Secy. Ira D. Maynor, E.R. F. P. Theierl and Youth Activities Chairman Biddy Beers, and Pres. D. C. Shonk and M. L. Johnson of the Buckskin Scout Council.





# They Made May Day American

(Continued from page 18)

home. An exhibition of Scouting skills and projects, displays and a Scouting-in-action demonstration, it was followed by a program during which the Elks Youth Committee presented Certificates of Appreciation to all Boy and Girl Scout Leaders of the county.

On May 1st, students of three high schools took over city management. A committee of Elks and faculty advisors prepared the students for their duties, and prominent Elk speakers addressed the three student assemblies at their respective schools.

Planning for the observance of St. Paul, Minn., Lodge which won third-place accolades began March 15th when it was decided to hold a special testimonial banquet on May 1st in honor of the outstanding participants in the Youth Leadership Contest, Scholarship Contest and Boy Scout program sponsored by the Elks. Invited guests were all the participants in these programs, together with their parents. The lodge hall was jammed to its capacity that evening when Youth Leadership awards totaling \$250 and 11 Certificates of Merit were presented by Youth Activities Committee Chairman Robert M. Worthington to 17 boys and girls; Scholarship awards totaling \$250 and Certificates were presented to 25 boys and girls. Six Scouts were also rewarded special achievement.

## Governor Present

P.E.R. Charles Rafferty, member of the city Board of Education, was Master of Ceremonies, introducing Mayor Joseph E. Dillon who, in turn, presented Gov. Orville L. Freeman who delivered an inspiring address and received a special citation from the lodge for his establishment of "Youth Town Meetings" throughout the State. Mayor Dillon received a similar token of appreciation of his fight against juvenile delinquency.

In this category, Lancaster, Ohio, Springfield, Vt., and Winslow, Ariz., Lodges won Honorable Mention.

Taking top honors for lodges of less than 500 members, the Fulton, N. Y., Salute to Youth was held on Saturday, May 5th, opened by the largest parade ever held in the community.

During the first week of May, a school work contest was held with pupils decorating store windows with their displays, and the Elks awarding plaques to the successful participants.

It is estimated that between 3,000 and 4,000 young people enjoyed the two-day program, with the Saturday events including all sorts of contests, a concert by the Kampus Kiddets of Oswego, a pushball demonstration by volunteer firemen, and a highly competitive amateur talent show. Highlight of the day was the rewarding of Youth Leaders of the area by State Youth Chairman James B. Hanlon.

The second day's activities was the famous Soap Box Derby which the lodge sponsors annually, this year in association with the All-American Soap Box Derby. The race was an outstanding success, with 50 cars competing in 48 heats for a total of ten awards. At least 4,000 Fulton citizens were on hand for the race whose winner will be sent to Akron, Ohio, at the lodge's expense, for the national event. Later, all Derby entrants were guests of the lodge at a picnic.

Elks Youth Day, as celebrated by San Benito, Tex., Lodge, won second place in Group III. On the morning of Saturday, Apr. 28th, all city offices were filled by high school students, and in the afternoon the Elks were hosts to about 3,000 elementary school children at a picnic on the grounds of Dr. C. M. Cash School, with softball games to watch, and foot races and relays in which the young guests vied for prizes.

Here, as in almost all other communities, special Church Services for our youth were held and on Tuesday, May 1st, the local high school assembly was addressed by P.E.R. Albert S. McGehee, with Charles C. Bowie, a member of the Grand Lodge Youth Activities Committee, presenting awards to the first- and second-place girl and boy winners in the local Youth Leadership Contest.

In third place for lodges in this group, Rocky Mount, N. C., Elksdom's well-planned program was a two-day affair, with the first events held on May 1st, and the second on the 4th. The first day's activities included refreshments and various races and contests for all 4th, 5th and 6th grade pupils of five elementary schools, with 600 children participating. About 900 youngsters took part in the Track Meet for Junior High School students which featured the second day's program. The winner of each competitive event received an engraved permanent trophy and the school making the highest

aggregate score was the recipient of a large and handsome permanent trophy. Group III Honorable Mention was awarded Chicopee, Mass., Hayward, Calif., Pascagoula, Miss., Reidsville, N. C., and Wellsburg, W. Va., Lodges.

## Maine Tops for States

When the Grand Exalted Ruler urged that Youth Day observances be "community-wide tributes to our youth that will demonstrate our partnership with them, our understanding interest in their affairs and our sincere purpose to help them prepare for tomorrow's responsibilities and opportunities", the Elks of Maine went all-out to show him they agreed. As a result their program was judged the finest of those offered by the State groups.

With the complete cooperation of Gov. Edmund S. Muskie, the First Annual Elks Youth Congress was held.

Escorted by 125 Elk dignitaries, 225 outstanding Junior Citizens from all over the State were honored at the Congress, held in Augusta when more than \$3,500 in awards was presented. The Elks included Chairman Brian M. Jewett of the Congress, a member of the Grand Lodge Youth Activities Committee, many State Association officials, and Leon F. Jones, Chairman of the Assn.'s Youth Activities Committee, who presented a \$300 Assn. Scholarship to Maine's Youth Leader, Chester Avery, Jr., a blind student who has been accepted as a law student by Harvard University. Gov. Muskie addressed the delegates to the Congress, all of whom appeared on television, and also presented Old Town Lodge's trophy to its basketball team which has won 57 games in three years. Also honored were the State Basketball Champions from Morse High School in Bath.

In this State Association category, the Committee awarded second-place honors to New York, third place to Washington and fourth place to California.



With Lt.-Gov. Sumner G. Whittier of Massachusetts, when he signed the Youth Proclamation for the Commonwealth are, left to right foreground, State Youth Leaders Norman J. Sheppard and Kathleen D. Lavigne, Past Grand Exalted Ruler John F. Malley and State Pres. Michael J. McNamara. In the background, left to right, are Chairman A. D. Kochakian of the Mass. Elks Assn.'s National Foundation Committee, Worcester Youth Activities Chairman F. X. Scott, State Assn. Youth Activities Chairman J. F. Lynch and former Chairman of that State Committee, Francis M. Cloran.



with Ed Faust



# In the Doghouse

No less than twenty-three of our Chief Executives have been owners of dogs.

G. WASHINGTON, ESQ., lately commander-in-chief of the armies of the United States, stood on the rear portico of his Mount Vernon home gazing in the direction of the kennels that housed his hounds. His usually austere features softened as he listened to the racketing of the dogs as they were being fed. After several bitter years in the field against the British it was good to be home again, once more to sweep through the Virginia hills with his friends and his foxhounds on the trail of that little four-legged ghost, the gray fox. (Because he was seldom seen in those parts the red fox was rarely hunted.) As a horseman few excelled Washington. Thomas Jefferson, who frequently disagreed with Washington in politics, in a burst of superlatives wrote of the latter that he was "the best horseman of his age, and the most magnificent figure that could be seen on horseback." As for the hounds, the Washington pack was known throughout the south and their fame was not unknown among many northern sportsmen. Their owner's interest in the hounds exceeded his earlier love of horses and in later life the pack became his foremost hobby.

Lafayette, commissioned Major General in the American forces when only 18 years old, became one of Washington's closest friends, notwithstanding the difference in their ages. From this friendship he soon learned about his commander-in-chief's interest in dogs and upon his return to France sent a pack of foxhounds to Mount Vernon. It is likely that the Washington pack was not the sleek, stream-lined variety of foxhound known to us today. According to George Washington Custis, Martha Washington's grandson by a former marriage, the dogs were enormous brutes, better built for grappling stags or boars than chasing foxes and so fierce that a huntsman had to preside at their meals. The biggest of the French hounds was the dog Vulcan singled out as a favorite by the family. From this we may believe that not all the hounds were as described by young Custis. But there came a day when the Lady of the Manor, expecting guests, ordered a magnificent ham to be prepared. Up to then Vulcan was an honest dog but the ham was his undoing. He swiped it and was thereafter exiled to the kennels.

As a dog owner, the Squire of Mount

Vernon was sometimes confronted by the usual problems that bother many owners and we find an account of his rubbing certain of his pack "with Hog's Lard & Brimstone" as a cure for mange. Whether he named his dogs or left this to someone else I don't know but you may agree that the following few are high and fancy. There was Sweetlips, Searcher, Singer, Chanter, Truelove and hold your hat!, Drunken and Drunken's young one, Topsy. Contrary to accepted belief, Washington was not the stern, puritanical person portrayed in some biographies of him. Mount Vernon saw many jovial dinners and other festive occasions during those few years when he wasn't burdened with public responsibility. If it were today we can well imagine him sitting at the ringside while some of his beloved hounds were being judged and perhaps celebrating an important winning by another lively dinner.

FROM Washington to Eisenhower dogs have been favored by many of our Presidents, some of them the greatest Executives our country has known. This is likewise true for many of our greatest people in art, science, literature, stage, industry, in almost every occupation.

Maria Monroe, first child to live in the Executive Mansion which later in 1817 was to become known as the White House, had for her pet a black and white spaniel. Incidentally, she was the first daughter of a President to be married from that house. Presidents Jefferson and Madison, as well as Monroe, came from sporting areas of Virginia. Naturally they were familiar with dogs, particularly those used for hunting. It's a matter of record that the bellicose Andrew Jackson maintained a kennel of well-trained gun dogs. Our ninth President, William Henry Harrison, favored coonhounds, foxhounds and retrievers. Following among dog enthusiasts were Presidents Tyler, Polk and Taylor. In the great heart of Abraham Lincoln dogs found a place. At various times in his lonely life he owned dogs and had a kind regard for them.

In front of the Lincoln National Life Insurance Company building at Fort Wayne, Indiana, stands a large bronze statue of Lincoln bearing the inscription, "Abraham Lincoln—the Hoosier Youth". It was the creation of Paul Manship, noted sculptor. It shows Lincoln as a young man, roughly dressed and with one hand on the head of a hound sitting be-

(Continued on page 46)

Pointer drawing by Charles Liedl

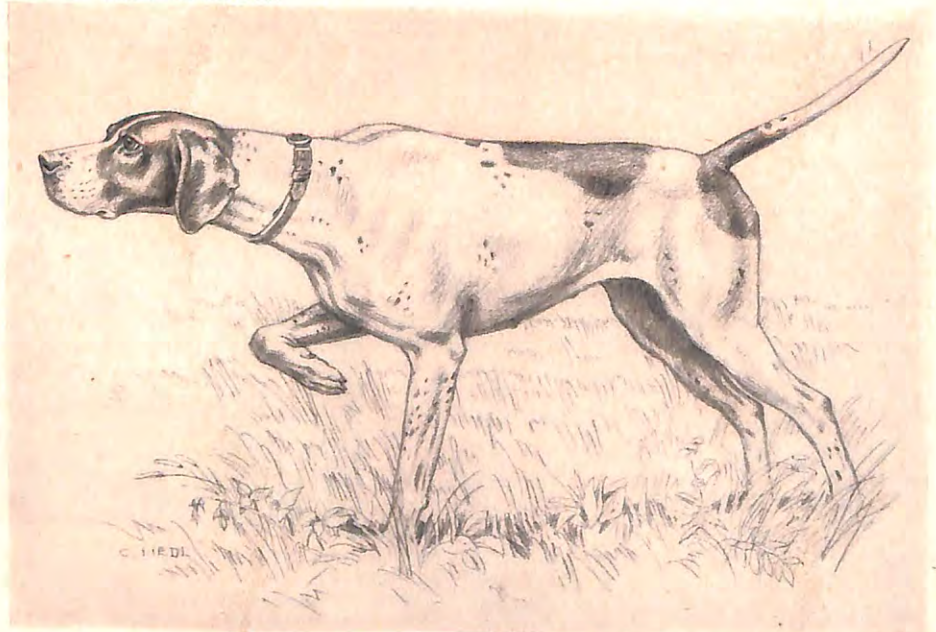

Sporting dogs, such as this pointer, have been perennial favorites of our Presidents.





## Seagram's 7 Crown is American whiskey at its finest

*All parties are in solid agreement on America's Number One whiskey. It's SEAGRAM'S 7 CROWN; year-after-year favorite of millions, by millions of bottles... America's first choice by the most overwhelming margin in whiskey history!*

**Say Seagram's and be Sure**

SEAGRAM-DISTILLERS COMPANY, NEW YORK CITY. BLENDED WHISKEY. 86.8 PROOF. 65% GRAIN NEUTRAL SPIRITS.



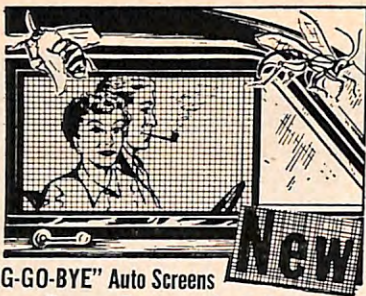

**"BUG-GO-BYE" Auto Screens**

**Keep Bugs Out — Let Breeze In!**

Drive or park in comfort during hot weather, without being bothered by bugs! Handy car-door window screens convert your auto into "screened-in room". Keep flies, mosquitoes, bees and other pests out—let cool breeze come in. Screens go up in seconds; hold without screws or hooks. Easy to remove; folds for storage in glove compartment. Fit all cars with door posts except hardtops. Made of sturdy non-metallic material; won't scratch car's finish. Only \$1.00 per pair plus 15c shipping charge. No C. O. D.'s. Satisfaction guaranteed or money back. Order today!

HOUSE OF SCHILLER, Dept. E-50  
180 No. Wacker Dr., Chicago 6, Illinois

**\$1**  
Per Pair

**WATER TIMER**

No more midnight trips to turn off the lawn sprinkler. This little gadget attaches to the water faucet and can be set to shut off the water automatically after any 10 minute period up to an hour. Avoids waste of water and soon pays for itself.

**\$5.95**

ppd.

Penna. Residents Please Add 3% Sales Tax

**TAYLOR GIFTS**

Wayne B7, Penna.



**WHO WILL WIN?**



hand carved ivory miniatures  
**ELEPHANT & DONKEY**

mailed to you from Delhi, India

Exquisitely detailed miniatures of the sacred elephant and donkey to bring you good fortune. Carved in precious ivory, here are superb examples of India's ancient, most respected hand craft. One inch high, you'll want them as good luck pieces during the election campaign; for prizes, children, collectors; to decorate desk or mantel. Order several for yourself, for gifts!

Postpaid, duty free. Pay postman only 15c foreign package fee. For air mail, add 25c each. Gifts sent in your name.

**\$2.00**  
only each

Satisfaction guaranteed or money back.

**SHOPPING INTERNATIONAL, INC.**

Dept. 18, 420 Lexington Ave., New York 17, N. Y.

**Elks FAMILY**

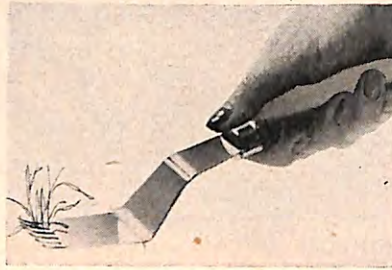

**CRACK DOWN ON CRAB GRASS** this summer. Prevent this pesty growth from getting a strangle hold on your garden by digging it out with Crab Jack. This efficient tool firmly grasps the grass and pulls it up, roots and all. Made of cadmium-plated steel with comfort-grip handle. \$1.00 ppd. Elron, 225 W. Erie St., Dept. E6, Chicago 10, Illinois.

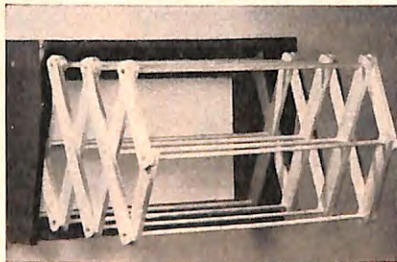

**NEED MORE SPACE** for indoor clothes drying? Wall Clothes Dryer has 12 drying rungs, each 20" long, folds compactly against wall when not in use. It's ideal for those rainy days when clothes can't be hung outside—and for the apartment dweller whose drying space is at a premium. Easily attaches to wall. \$5.95 ppd. Taylor Gifts, Dept. E, Wayne, Pa.

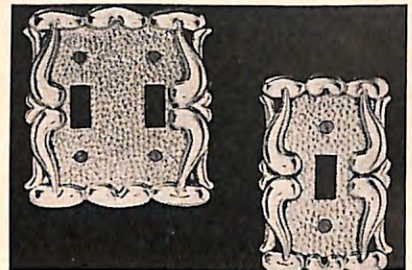

**ANTIQUE IN SPIRIT** though not in use is this new Switch Plate. The graceful scroll design makes a handsome wall decoration of an ordinary light switch. Antiqued brass-plated metal. Matching screws included. Single (3" x 5"), \$1.50 ea.; 3 for \$3.95. Double (4 1/2" x 5"), \$1.95 ea.; 3 for \$5. ppd. Ruth Brawer, Box 4035, Dept. ESW, Tucson, Arizona.



**TWO-IN-ONE PROTECTION** for your knee-bruising household and gardening chores. This clever apron holds a soft foam rubber knee pad in each of its two roomy pockets. Strong, yet comfortable elastic bands hold pads to knees so they move along with you. Apron and Knee Pads, \$1.25 ppd. Home Shopper, Dept. EJ-1, 667 N. Fairfax Ave., Los Angeles 36, Calif.

Merchandise shown on these pages can be ordered direct from the companies listed. Enclose a check or money order.



**FOR Your Favorite Elk**

Here is an official Elks pin, approved by the Grand Lodge, specially designed for that member who has been an Elk for 30 years. As are other pins designating membership or years in the Order this pin enameled red, white and blue as shown is a truly handsome example of craftsmanship. Any Elk entitled by years of membership to wear it will be proud to display it. It is a life-long gift that will bring years of fond memory of the one who gives it. Three varieties—one #10 plain with no jewel—\$8.25. #10A Some design but set with one blue sapphire—\$9.90—Third pin #10B set with sparkling diamond \$19.00. All three 10kt gold with gold plated post and attaching button. Please order by number. Prices include Federal tax. For N. Y. City orders add 3% sales tax. Sent post paid including insurance. Allow two weeks for delivery. Order your gift pin TODAY from THE ELKS MAGAZINE, 386 Fourth Ave., N.Y. City 16, N.Y.



**Stop Dog and Cat Damage—\$1**

**DOG WICKS** are the perfect solution for repelling pets. One sniff and away they'll run! Hang this chemical Wick on shrub or branch and rest easy for the whole season. Rain won't wash away repellent scent. Safe, harmless to animals. Use inside or out—protects lawns, garbage pails, flowers, furniture. Trains your pets and neighbor's dogs. Guaranteed to do the job or your money back! Pack of 20 for \$1, postage paid. Order DOG WICKS direct by mail from Sunset House, 404 Sunset Building, Hollywood 46, California.

**IMPORTED MEXICAN SERVING TRAYS**



Hand carved lightweight wood with gaily hand painted flowers in colorful array on black background and lacquer protected. Approximately 16" diameter 1 1/2" deep (weight 1 1/4 lbs.). No two subjects identical. Donate a set of 3 to your church. Ideal for wedding presents. Perfect wall decorations. \$3.50 each or 3 for \$10.00 postpaid. Check or money order, no C.O.D.

**MEXICAN SPECIALTY IMPORTS**  
Dept. M-52 P. O. Box 8007, San Antonio, Texas



# SHOPPER



**BARBE-CUTIES** make a sizzling success of your cook-outs. The compact kit includes colorfully handprinted apron, chef's hat to match (fits all head sizes) and hot pad mittens with double, colored felt palms. They're all packed in reusable plastic refrigerator bag. \$3.95 ppd. House of Morgan, Dept. E, 238 So. Mariposa Ave., Los Angeles 4, California.



**COOK A MAN-SIZE MEAL** on this pocket-size alcohol stove. Indoors or out, its 8 oz. is worth triple the weight in gold—for camping, beach trips, emergencies, as a replacement unit in chafing dishes. 5¢ worth of alcohol gives 3 hours of cooking. Instant heat and gas-type flame regulator. \$1.98 plus 25¢ postage. Matthew Day Co., Dept. E, Dumont, N. J.

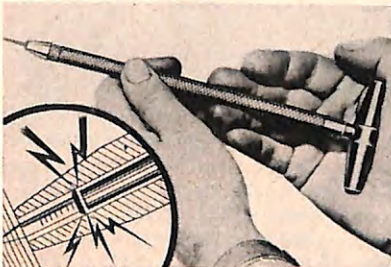

**RAMMER HAMMER** rams small nails home surely and safely, replaces the hit-and-howl method of ordinary hammer. Its magnetic tip holds nail or brad securely in place while you drive it home with short raps on the handle with palm of the hand. Plated steel and brass. \$2.00 ppd. Beatty Mfg. Co., Dept. E, 3450 Wilshire Blvd., Los Angeles 5, California.



**SEA SAUSAGE.** This hot dog brings cool fun with safety to youngsters at the shore or lake. It's buoyant enough to give three young ones a water ride. Inflates easily, measures 55" long, about 12" thick when ready for the water. Made of heavy vinyl with heat-sealed seams and foolproof valve. \$1.50 ppd. Miles Kimball, Dept. E, 99 Bond St., Oshkosh, Wisconsin.

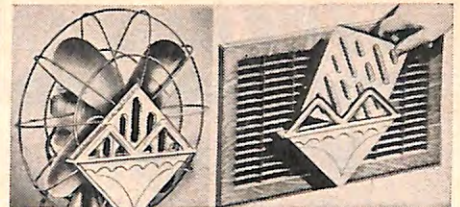

**Beat the Heat!**  
Get SEA BREEZES with FAN AIR-COOLER

**Only 98c** Enjoy cool, refreshing comfort on even the hottest, most sultry days. New Air-Cooler cools by evaporation; it clips on to any fan or vent in 5 seconds. Simply fill tank with water, insert specially designed Dupont cellulose sponge, and turn on fan. Instead of blowing hot air at you, the air is cooled by the water—it's just like an invigorating sea-breeze. Large tank capacity; made of durable, quality Styrene, 8" in diameter; fits any fan or wall register, large or small. Ideal for winter use too; as a humidifier, makes air feel warmer. **ONLY 98c.** Add only 15¢ for postage and handling. Satisfaction guaranteed. No C.O.D.'s please. **BANCROFT'S**, 1112 S. Wabash, Dept. EL-757, Chicago 5, Ill.



**WIGWAM WEDGE MOCCASINS.....\$5.95**

of glove-soft, smooth, washable calfskin, they cuddle your feet and make walking a pleasure. Built-in wedge heel. 5 lovely shades: White, Natural, Turquoise, Red, Charcoal—with intriguing pinwheel bead design. Sizes 3 thru 10, narrow and medium—½ sizes too. . . . \$5.95  
Send cash, check or m.o. For COD's send \$2 deposit.  
Box 4035, Dept. ELW  
Tucson, Ariz.

**OLD PUEBLO TRADERS**

**"MY GREY HAIR IS A NATURAL LOOKING COLOR AGAIN!"** says **JAN GARBER,**



Idol of the Airlines  
"TOP SECRET gives my grey hair a natural looking color!" says famous dance band leader Jan Garber. "I noticed results after just a few applications. And TOP SECRET is easy to use—doesn't stain hands or scalp. TOP SECRET is the only hair dressing I use."



**A FAVORITE OF THE STARS**

TOP SECRET has been a favorite with famous personalities for years. Exclusive formula imparts a natural looking color to grey or faded hair. Does not streak or injure hair; does not wash out. Send \$5.00 (Fed. Tax incl.) for 6 oz. plastic container. (Convenient for traveling, too.) Ppd. No COD's, please. Money back if not delighted with results of first bottle. Albin of California, Room 74, 1401-91 W. 8th St., Los Angeles 17, Calif.

Except for personalized items, there is guaranteed refund on all merchandise returned in good condition within 7 days.



**DRIVEWAY STAINS VANISH...\$1.00**

Cars drip oil and grease causing ugly, stubborn stains and spots on your driveway, garage floor. Just sprinkle on this amazing new Stone-Off powder, then wash away as instructed. Presto! Cement is sparkling clean again! Removes stains from patios, brick, cement, blacktop. Money-back guarantee. Only \$1.00 ppd. for big 12 oz. box of this miracle cleaner (2 boxes \$1.89). Order today from The Home Shopper, Dept. E-25, 667 N. Fairfax Ave., Los Angeles 36, California.



**"L-O-V-E My Flea-Scat-Pad!"**

"It's wonderful—kills fleas and doggy odor while I snooze. I love its cedar aroma, its clean comfort." Protects children. Stops scratching. Ends all struggles with messy powders, sprays. Keeps pets off chairs, sofas. Pleasant in any room. Economical, long-lasting. **Flea-Scat-Pad**, 15x28 in., \$3.49. Super size, 28x36 in., \$4.98. **Kitty Cootie-Chaser** the pad for Cats, 14x18 in., \$2.49. Send check or M.O. and we pay postage. **Money-Back Guarantee.** Sudbury Laboratory, Box 25C, South Sudbury, Mass.

**KEEP CESSPOOL TROUBLE AWAY**

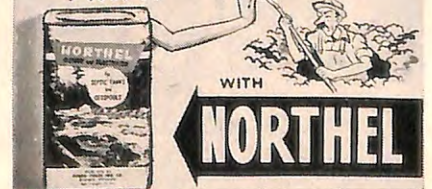

**Suburban & Country Dwellers**

**NORTHEL Reactivator** keeps septic tank and cesspool clean. A bacteria concentrate breaks up solids and grease—prevents overflow, back-up, odors. Regular use saves costly pumping or digging. Simply mix dry powder in water, flush down toilet. Non-poisonous, non-caustic. Guaranteed to reactivate septic tank, cesspool. Six mos. supply (23 ozs) only \$2.95 ppd. Northel Distributors, EM-7 P. O. Box 1103, Minneapolis 1, Minn.



# HI-SPEED HOME & CAR WASHER

with 2 washing heads

REGULAR  
**4 98**



Now **1 98**

**FREE!**  
**DETERGENT PELLETS**

Wash your car 10 times **FREE!** Place magic detergent pellet in hydraulic sudser. Bursts into foamy suds as water flows thru. Road dirt dissolves & slides off. No streaks! 10 Pellet Package free with your washer.

**Wash Away Dirt Quick! Easy!**

Now . . . in one single operation, you can scrub, . . . suds, . . . rinse! Simply attach to hose . . . wash cars, barns, chicken coops, troughs, windows, porches, screens, outside walls of your home in **HALF** time! No splash! New, improved model now has 2 washing heads instead of one! Change over in seconds. An automatic **HYDRAULIC SUDSER** is built in Now—suds, wash, scrub and wipe off in one easy operation!

**Save Labor! Save Time!**

Wash away accumulated soot from outside your home—save an expensive paint job! Wash your car in just minutes with no back or arm strain—without splashing or getting messy. Cleans screens, porches, tiles, awnings, storm windows, boats, floors. New 3 section handle! Make it long, make it short to suit yourself! Extends from **ONE** to **THREE** feet! Complete kit—a \$4.98 value—including Pellets, 2 Heads, 3 Section Handle—all yours for \$1.98 complete. Order yours **NOW**—on full week's home trial. Satisfaction guaranteed or money back! Send 1.98 check, cash or m.o. for prompt prepaid delivery. (C.O.D.'s plus postage.)

**EXTRA DETERGENT PELLETS:** Available in packages of 24 pellets at \$1. Car washes only cost you 4 cents each! Check special box in coupon.

**No Splash!**

(Copyright 1954 M-M Co.)

**← 2 HEADS →**  
Now—two heads instead of one. Besides the non-scratch brush you get a **SQUEEGEE-WIPER** head. Ideal for all smooth surfaces, windows, cars, etc. It **WIPES** as it washes. Has silky-soft Polyethylene circular squeezer.

**MOTO-MATIC CO., Dept. 103-G-44**

352 Fourth Avenue, New York 10, N. Y.

RUSH newest HI-SPEED (4.98 Value) for only 1.98—on 7 Day Free Trial. Includes 3 section handle, 2 heads, built-in hydraulic sudser & 10 magic detergent pellets. If not delighted, I'll return for immediate refund. ( ) 1.98 enclosed. Rush prepaid. ( ) Send COD plus postage.

Name.....

Address.....

City..... State.....

**SPECIAL OFFER:** Send extra package of 24 pellets—enough for 24 washing jobs, for only 21 more.

# Elks FAMILY SHOPPER



**YOUR POCKET CHANGE** might be a gold mine. Rare coin concern publishes an illustrated U. S. Coin Catalog of hard-to-find coins it wants to buy. For instance, they'll pay up to \$2,000 for the rare 1908 silver dollar! Catalog costs just \$1.00 and that's refunded when you sell them any coin. Send \$1.00 to Byymail, Dept. 1, Box 488, Hempstead, N. Y.



**OUT-OF-ACTION PAINT BRUSHES** can be cleaned, preserved or reclaimed in Protexem. The vapor action in this brush conditioner penetrates hard-as-rock brushes, makes them good as new and keeps them that way. Container stores 6 to 8 brushes up to 5" wide, 14" long. Container with 1/2 pt. solvent, \$2.95 ppd. Meridian Products, Dept. E6, 366 Madison Ave., New York 17, N. Y.



**NO TIPPING.** Youngsters don't have to stand on tippy chairs to reach the light switch if you install Kiddiklik. This clever, non-breakable aluminum handle attaches easily to switch. In anodized colors: rose, aqua, char-treuse, gold. Get two, for bedroom and bath. \$1.00 ea. ppd.; 2 for only \$1.89 ppd. Kiddiklik, Dept. E-1, 9324 Appleby St., Downey, Calif.



**THREE WAYS TO LOOK AT THE WORLD:** Wall-Size Map, Rand McNally World Atlas and Stamp Packet of over 200 foreign stamps. 52" x 34 3/8" World Map is printed in 8 colors with clear type. 32-page Atlas is 11" x 14", printed in 4 colors, shows latest political boundaries, populations, important world regions. All 3, \$3 ppd. Terry Elliott, Dept. E-22, 135 E. 44th St., New York 17, N. Y.



**Hot Water with HOT ROD**

Traveling light? Brew your own powdered coffee, tea or soup with the new Hot Rod. Metal AC/DC heating element hangs on edge of cup or bowl, brings contents to boil in a minute. In red genuine calf pocket-size case. Extra plug for European outlets. **Only \$4.95** Clarion Products, Box 488KS, Highland Park, Ill.

**NEW! SNAP FLOAT**

Automatic—Every nibble a hooked fish! Slightest tug on line releases spring, which jerks line and sets the hook. With complete instructions, \$1.25 each post-paid. No CODs. Guaranteed.



**HARTMAN'S PRO SPORT SHOP**  
121 Addison, Elmhurst, Ill.

**ATTENTION ALL ELKS—**  
**SEE THE 1956 CHICAGO CONVENTION IN NATURAL COLOR SLIDES**

This year, a complete set of 50 (fifty) 2"x2" Color Slide highlights of the 92nd Grand Lodge Convention in Chicago this July. Scenes include Business Sessions, State Association Meetings, Drill and Ritualistic Teams, Bands, Award Winners, Installation Ceremonies, Elks National Memorial Building and many other activities of the convention. Invaluable to all lodges, Exalted Rulers, District Deputies and State Association Officers. Show your members and friends the Convention in natural color! Slides may be projected on a screen or viewed in smaller groups with the popular hand viewer.

**COMPLETE SET 50 COLOR SLIDES—**  
**ONLY \$9.95 POSTPAID**

(10% discount on paid orders on or before July 5.) Satisfaction Guaranteed. **ORDER NOW** by Check or M. O. from **COLOR SLIDES, P. O. BOX 1, SISTERSVILLE, W. VA.**

Delivery approx. Aug. 1st.

One Picture Equals 1000 Words . . .

**OPENS CLOGGED SINK WITH ONE STROKE**

Now you can stop using strong chemicals that eat away pipes; cause high plumbing bills; ruined clothing; spattered floors and walls; plus risk of injury to eyes or skin. **DRAIN-BLO** is completely safe in use. Builds up to 60 lbs. pressure, and with one fast downward stroke instantly opens up clogged sink. Light and easy to use. Sturdy 13 1/2" long. Fits all sinks except those with garbage disposal unit. Order **DRAIN-BLO** now to have handy when needed. Send only \$3.98 for postpaid delivery. Postage added on C. O. D. orders.

Money-Back Guarantee  
**MERIDIAN CO.**

Dept. B-36

366 Madison Ave., New York 17



For Kitchen Sinks only

**ONLY \$3.98 Ppd.**



# ELKS FAMILY SHOPPER



**LONG AUTO TRIPS** are less fatiguing when you prop up your back with Driverest, a plastic foam cushion scientifically designed to fit the small of your back. Its companion piece, Sacrorest, acts as a shock absorber for the sacroiliac, is padded for comfort. Driverest, \$4.95; Sacrorest, \$2.95 ppd. Mastercraft, 212 E Summer, Boston 10, Mass.



**HEADLINE TOWELS** make kitchen news. So aptly worded, they're sure to get chuckles from guest and family. The designs are all original, handprinted on pure ecru linen. Choice of red, pink or aqua printing. Because they're especially clever for a new bride, we love them for shower gifts. 16" x 30". Set of 3, \$2.95 ppd. Lee-craft, Dept. ELL, 300 Albany Ave., Brooklyn 13, N. Y.



**COMPLETE YOUR SLIDE COLLECTION** with colorful, fascinating scenes from 57 countries. 4,000 35mm Kodachrome slides are listed in this 40-page catalog. Scenes include interiors of the Louvre, St. Peter's, Paris night life. 25¢ cost refunded on first order. Stereo catalog listing 1200 views included free. Wolfe Worldwide Films, Dept. E, 10916 Ashton Ave., Los Angeles 24, Calif.

Please mention The Elks Magazine when writing to our Elks Family Shopper Advertisers.

## AMAZOY Likes It Hot PLANT NOW!

**YOUR LAWN STAYS GREEN WHEN OTHERS BURN BROWN**

### AMAZOY THRIVES IN HEAT!

Develops best and spreads fastest when planted in hot weather. This superior grass may be transplanted all summer long. Plant it now. AMAZOY stays rich green even in blistering heat, drought or water shortage.

### CHOKES OUT CRABGRASS, WEEDS

Grows so thick it chokes out weeds and crabgrass. Resists diseases, even insects can't live in it.

### SAVES WORK • TAKES PLAYGROUND PUNISHMENT

Because AMAZOY grows slowly upward, cuts mowing by two-thirds; Gives a carefree, perennial lawn ideal for paths and children's play areas; so resilient it takes heavy trampling—springs right back. Costs less in the long run than any grass known because it never needs reseeding. A truly lifetime carefree lawn.

### GUARANTEED TO GROW IN YOUR SOIL

Scientifically packed to reach you fresh and vigorous. AMAZOY'S method and specially winter hardened stock are so proven we guarantee every plug. Stays green till frost. Regains rich green beauty every spring. Any plug failing to grow will be replaced absolutely FREE.

### ORDER FROM WORLD'S LARGEST GROWER

Our thousands of satisfied customers have made us the world's largest producers of this outstanding lawn grass. Take no chances, avoid risk of lost labor and disappointment with inferior grades by ordering genuine AMAZOY today.

### DEPT. 229 ZOYSIA FARMS

602 N. Howard St., Balto. 1, Md.  
333 N. Michigan Ave., Chicago 1, Ill.



APPROVED BY U. S. GOLF ASSN. Used on famous courses

**FREE! Reg. \$4.95**  
2-WAY STEP-ON PLUGGER

With orders of \$11.98 or more, we enclose our new patented Step-On Plugger... plugs lawn and destroys harmful competing grass at same time. NO ONE ELSE CAN OFFER YOU THIS WORK SAVING GROWTH PRODUCING 2-WAY PLUGGER.



# ORDER THE ONLY ZOYSIA GRASS PICKED BEST BY U. S. GOV'T.

NOW AVAILABLE FROM THE WORLD'S LARGEST GROWER

- KILLS CRABGRASS & WEEDS
- 2/3 LESS MOWING
- NEVER NEEDS RESEEDING

GROWS SO THICK PIMLICO RACE TRACK planted AMAZOY on turf course.

RELEASED & APPROVED BY U. S. GOV'T.

The approved strain of Meyer Z-52 is the ONLY ZOYSIA sold under exclusive AMAZOY TRADEMARK (reg. U.S. Pat. Off.). Certified to be highest caliber Meyer Z-52 Zoysia—the new lawn grass developed and released by U.S. Gov't. as most satisfactory lawn grass ever known.

### EASY TO PLANT—GROWS IN ANY SOIL

AMAZOY comes direct to you in pre-cut living grass plugs—NOT messy sod or wasteful seed. When planted on 1 ft. centers in checkerboard pattern, gives hundreds of transplants yearly. Grows where other grasses have failed. Perfect for hills, for clay, sandy soil—even beaches. Guaranteed not to winter-kill.

### ORDER BY MAIL—CUT OUT COUPON

#### DEPT. 229, ZOYSIA FARMS

602 N. Howard St., Baltimore 1, Md.  
333 N. Michigan Ave., Chicago 1, Ill.

Please ship the following order of AMAZOY Meyer Z-52

- |                                                   |         |                                                   |         |
|---------------------------------------------------|---------|---------------------------------------------------|---------|
| <input type="checkbox"/> 50 Plugs                 | \$4.98  | <input type="checkbox"/> 300 Plugs & Free Plugger | \$24.98 |
| <input type="checkbox"/> 100 Plugs & Free Plugger | \$11.98 | <input type="checkbox"/> 650 Plugs & Free Plugger | \$49.98 |

West of Miss. River only, add 75c per 50 plugs for shipping. (We pay postage East of Miss. R.) Sorry No C.O.D.'s.

I enclose  check  Money Order  Cash

Name.....

Address.....

City.....Zone.....State.....

# Do You Really Know Elkdom? Do You Know—

1. When the Order began?
2. Who started it?
3. How the Ritual originated?
4. How the 11 o'clock toast was created?

Here's a book of 432 pages packed with many not widely known facts about the Elks, interesting and written by an authority. It's durably and beautifully bound making it a fine gift or valuable addition to any Elks Lodge library or the home of any Elk. It is the only book that gives the year-by-year story of the Order of Elks—its growth and achievements. Send for your copy TODAY to The Elks Magazine, 386 4th Ave., New York 16, N.Y.

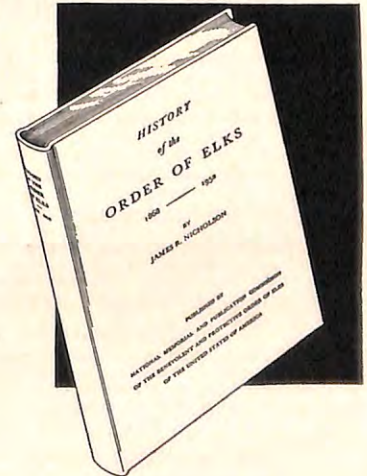

**\$4.17**

(incl. postage & Ins.) if ordered within N.Y. City limits please add 12 cents for City sales tax.

Published by the National Memorial and Publication Commission of the Benevolent and Protective Order of Elks of the United States of America.



# Portable Electric VACUUM CLEANER goes with you everywhere...

Easily worth  
\$10  
to you...

OUR  
PRICE  
**3.99**

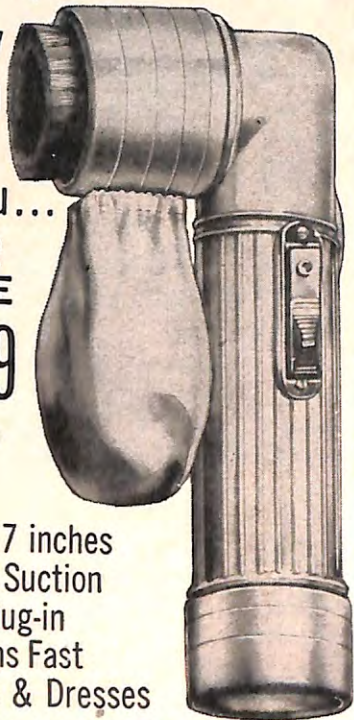

- Only 7 inches
- High Suction
- No plug-in
- Cleans Fast
- Suits & Dresses

## GETS TO DIRT THAT BIG VACUUMS CAN'T REACH

New high power vacuum—only 7 inches high! Weighs less than a pound. Fits bag or glove compartment—travels with you everywhere! High speed motor works on 2 flashlight batteries. Removes lint, dust, surface dirt from clothing in seconds! Better, faster, more thorough than a brush for soft fabrics, flannels, velvets, suede, etc. Circular brush gets at encrusted dirt, saves on cleaning bills.

### Use for Car Upholstery

Keep one in glove compartment. Handy and practical for hundreds of household jobs too—cleans pockets, cuffs, upholstery, typewriters, dandruff specks, ash trays, table crumbs, drapes—in fact, anything a big vacuum can't reach. Well constructed. Lasts years.

### 7 DAY TRIAL

Send \$3.99 check, m.o. or cash for prepaid delivery. COD's sent, plus postage. Try 7 days FREE. Satisfaction guaranteed or money back! NOTICE: Last time this vacuum was advertised, it sold out in 3 days. Don't risk disappointment. Order NOW. Mail Coupon Today!

Mrs. Lavalie, Dept. 103-G-36  
585 Water Street, New York, N. Y.

## 7 DAY TRIAL!

MRS. LAVALLE, Dept. 103-G-36  
585 Water Street, New York, N. Y.

Send \_\_\_\_\_ Vacuum Cleaner(s) at 3.99 on 7 Day Trial, Money-Back Guarantee.  
 Payment enclosed. Send Prepaid.  
 COD, plus postage

Name \_\_\_\_\_

Address \_\_\_\_\_

Town \_\_\_\_\_ State \_\_\_\_\_

CANADIANS: Address 45 St. James West, Montreal 1, P.Q.

## World Famous Perfumes



Imagine! 25 world famous perfumes at this low, low price. Leading fragrances that sell for as much as \$20 an ounce! Kit contains 25 Nips, each with enough perfume for one liberal application. Special booklet tells how to select perfume best suited to yourself. Makes fascinating reading . . . and it's pure enchantment to try a new perfume every day. 25 Perfumes & Booklet only \$1.10 ppd. Order from HUSS BROS., 800 N. Clark Street, Dept. 8-G, Chicago 10

## GOLFER'S KOLOR-KODE

No More Club Errors! No More Searching!



Bold Numbers on Different Brilliant Color for each club. On in seconds. Guaranteed permanent and weatherproof. Wears like Iron. One round and you'll wonder how you ever got along without Kolor-Kode! The Tournament Pros are using them.

Designed for use on ALL makes of clubs.

COMPLETE SET \$1.95 PPD.

STRATTON SNOW Dept. E DELRAY BEACH, FLA.



## For ELKS—the Gift unusual

Give your favorite Elk one of these 10kt gold, beautifully enameled red, white and blue Elk insignia pins. It's a life-long gift that he'll proudly wear while always remembering the giver. Post and attaching button gold plated. Please order by number. No. 7 plain pin, no jewel, ppd \$7.35. No. 7S Same as 7 but set with one genuine blue sapphire, \$11.00. 7A Set with genuine diamond, \$20.15. 7B Same as 7A but containing larger diamond, \$28.40. Prices include Federal tax. Order your Christmas gift pin TODAY. Delivery within 2 weeks. For N. Y. City purchase add 3% sales tax. Dept. S, THE ELKS MAGAZINE, 386 Fourth Ave., N. Y. City 16, N. Y.

## ELKS FAMILY SHOPPER

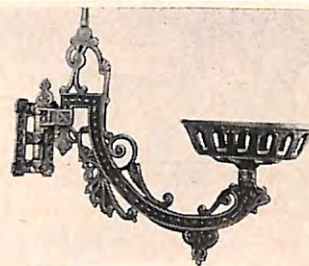

**IT SWINGS.** The Gay-Nineties charm of this Swinging Wall Bracket makes it a pretty and novel foil for plant or lamp. A hand-cast reproduction of an old-fashioned lamp holder, it's made of wrought iron, finished in satin black. Extends 11" from wall, bowl diameter is 3½" at base. \$3.75 ea., 2 for \$7.50 ppd. Stern's Nurseries, Dept. PG. Geneva, N. Y.



**KARRY-KART.** This versatile pair of wheels gives you a lift with household chores. Whether it's carrying heavy groceries, lifting wet laundry, rolling out garbage cans, this convenient carry-all bears the load. Of lightweight steel and aluminum. Karry-Kart alone. \$5.98; with handy bushel basket and plastic liner. \$6.98 ppd. Sportsman's Post, Dept. E, 366 Madison Ave., New York 17.

## MIGHTY GILHOOLIE OPENS AND RESEALS ANY BOTTLE OR JAR

Strong-arm Helper  
for Kitchen or Bar



ONLY \$2.95  
Postpaid

Even the daintiest feminine hand has giant's grip when MIGHTY GILHOOLIE is used to open bottles and jars. MIGHTY GILHOOLIE takes light out of most stubborn screw-top, from nail polish to big jars. Lifts soda caps and pry-off lids with greatest of ease. Does job so neatly and without distortion, perfect re-seal job can be done. Not a gadget, but a handsome precision tool. Made of stainless steel. Saves foods, beverages, money. Get one for yourself—others for friends. SATISFACTION GUARANTEED. ONLY \$2.95 postpaid. Send check, money order or cash. If C. O. D., plus charges.

MERIDIAN CO., 366 Madison Ave., Dept. M-32, New York 17

## Golfers WHAM-O® for practice

NEW! GROOVE YOUR SWING AT HOME!  
DEVELOP FORM - CORRECT HOOK AND SLICE!



**FOR WOODS AND IRONS - USED BY PROS**  
**No ball to chase!** Simply push into ground and hit. Returns to position after club swing. Imperfection in your swing is indicated by action of Wham-O. Practice just 5 minutes a day with our instructions and play 100% better on Sunday! Folds to 8" for golf bag. Use to warm up at starting tee. Tough pliable plastic, ash hardwood stock. 5" steel spikes. Withstands violent abuse. Only \$1.95, complete. Guaranteed. Ideal gift. At dealers or write: WAMO MFG CO., Box 1-15, San Gabriel, Calif.

## 8 X 10 COLOR PRINTS

All Orders Returned 1st Class  
ANSOCROME & EKTACHROME  
rolls processed—120, 620 and 20 exp.  
35 MM (mtd).....\$1.00  
KODACHROME—20 exp. ....\$1.25  
35 MM duplicates 20c each  
KODACOLOR CU processed 90c roll.  
Prints 27c each  
No C.O.D.'s—Minimum Order \$1.00

\$2.00

LOW PRICED  
COLOR PRINTS  
2¼x3¼ . . . 30c  
3x3 . . . 40c  
3x4 ½ . . . 50c  
4x5 . . . 75c  
5x7 . . . \$1.25

## ACME COLOR PHOTO LAB.

Box 6025-E Minneapolis, Minnesota





# Excerpts from Annual Reports Submitted to the Grand Lodge

AT CHICAGO IN 1956

## THE GRAND EXALTED RULER

## Elks National Foundation

**P**RESENTING his report to the Grand Lodge, Grand Exalted Ruler John L. Walker opened by saying, "For the 17th consecutive year our Order has shown a substantial net increase in membership. The membership on March 31, 1955, was 1,149,613 and the figure for March 31, 1956, was 1,173,494, a gain of 23,881. It is significant that this increase in membership rolls came despite a most vigorous and radical cleaning up of our membership rolls through the dropping of members for nonpayment of dues, many of whom had been carried on the rolls for long periods of time . . .

"We can all be very proud, therefore, that in the face of this important housecleaning work that has been accomplished, we were nevertheless able to show a substantial net gain in membership."

The Grand Exalted Ruler pointed out that Elkdom has continued to expand geographically and during the lodge year 31 dispensations were granted and 38 new lodges were instituted. (*Note: for complete details refer to the Grand Secretary's Report on page 38*).

### Membership Control

"With a membership that is nearing a million and a quarter, and with our lodges nearing the 1,800 mark, the Order of Elks is a huge enterprise . . . I have the firm conviction that the time has come when the Grand Lodge must take positive action to increase the efficient operation of our lodges and clubs, to reduce appalling waste through lapsation of members, and to promote the sound expansion of the Order at a faster rate," Mr. Walker said.

Mr. Walker expressed his conviction that the Grand Lodge should take active steps to rehabilitate lodges that are in trouble before it is too late, and also that there is particular opportunity for growth in the suburbs of our large cities, as well as in the cities themselves. He noted that while the Constitution was amended in 1951 to permit expansion within large

cities, thus far the authority has not been utilized.

Turning to the subject of lapsation, Mr. Walker commended 39 lodges for having 100 per cent paid up memberships without lapsations during the year, and in some cases for many years, but suggested a more continuing, persistent well-planned attack on lapsation, with the responsibility more clearly defined and centralized. He made the point that a study should be made of the successful methods used by lodges with outstanding lapsation records, and furthermore, that this information should be made available to all lodges as part of a continuing program to reduce lapsation.

Another factor in the lapsation problem, the Grand Exalted Ruler believes, is the failure of all too many lodges to indoctrinate new members thoroughly with a knowledge and understanding of Elkdom and its achievements.

Still another point that the Grand Exalted Ruler made was the failure to extend to new lodges the help that they need to get started during their formative years. This, the Grand Exalted Ruler feels, is basically a problem for the State Associations and deserves considerable study.

The Grand Exalted Ruler reported a reluctance on the part of some lodges to have new lodges instituted nearby even though there is both a geographic and population justification for the new lodge because of the rapid growth, especially in suburban areas, since the war. He pointed out that this attitude is unreasonable and mentioned particularly the case of two lodges in California, each of which is within five miles of a lodge instituted this year. A few weeks after the new lodge was instituted, District Deputy Gerald F. McCormick wrote to the Grand Exalted Ruler and reported that in spite of the original doubts of the two older lodges, they were now confident that they would be strengthened by the institution of the new lodge and, in fact, expected to enjoy a substantial membership gain this year.

"I set for my administration the goal of a contribution to the Elks National Foundation from every Elk, every lodge and every State Association. I realized of course that that was an ambitious undertaking and probably beyond attainment, but little is ever accomplished by striving for easily attainable goals," said the Grand Exalted Ruler.

"However, I can proudly report that the total amount of money contributed to the Foundation in the year ended on April 30, 1956, amounted to \$403,802.17—by far the largest amount ever subscribed to the Foundation in any of its previous twenty-seven years. More importantly, the number of individuals who made contributions to the Foundation is likewise the largest on record. The aggregate contributions by individuals of \$224,247.77 represents an increase of 35 per cent over last year.

"The Foundation Campaign was very close to my heart, because I believe that in the Foundation, Elkdom has its greatest opportunity for constructive and significant social service," Mr. Walker stated.

### Past Grand Exalted Rulers

"It is impossible to over-emphasize the important part played by these distinguished leaders in making the Order of Elks what it is today. All Elks are inspired by, and indebted to, them for their eminent service to Elkdom. They have built it upon a solid foundation, and I shall always be most grateful to them. Truly it may be said that they 'Serve Elkdom—Live Elkdom,'" the Grand Exalted Ruler stated in expressing his deep appreciation for their assistance.

### Appreciation of Assistance

Mr. Walker particularly expressed his gratification for the assistance he received from his District Deputies. "To  
(Continued on page 36)



them I shall always be indebted for the fine support they gave my Membership Control Program and campaign for the Elks National Foundation," he said.

He also thanked Floyd H. Brown, Special Representative of the Elks National Service Commission, for the work he did for him as Special Deputy.

Mr. Walker noted the helpful cooperation received from Brother Otho De Vilbiss, Director of Public Relations, throughout the year.

Expressing appreciation to Grand Secretary Lee A. Donaldson for his help, the Grand Exalted Ruler said: "He served with distinction and has contributed much to the success of my administration. I am greatly indebted to him for his fine support and cooperation."

The Grand Exalted Ruler then expressed his sincere thanks for the able assistance of the Board of Grand Trustees, Grand Treasurer Edward A. Spry and the other Grand Lodge officers, after which he noted the outstanding service rendered by his Secretary, F. Haden Vines of Roanoke, Va., Lodge, and his secretarial and stenographic staff.

Mr. Walker paid tribute for the work and aid contributed by the Elks National Service Commission and all other Grand Lodge Commissions and Committees.

## Recommendations

The Grand Exalted Ruler made twelve recommendations, which we report in their entirety as they appear in his Report:

1. That we employ a full-time man for Lodge Rehabilitation work, and that until such man is obtained authority be granted to use part-time assistance as needed in the various areas.

2. That the budget for Lodge Rehabilitation and Membership be increased to \$20,000.

3. That the Grand Exalted Ruler be authorized to appoint a Special Committee to study the problems of lodges in large cities and make recommendations.

4. That the budget of the Grand Secretary be increased sufficiently to enable him to make a study of lapsation and to supply lodges with information on most successful methods used to reduce lapsation.

5. That it be made mandatory that a copy of "What It Means To Be An Elk" be given by each lodge to every initiate.

6. That the Grand Secretary develop a program of member indoctrination with specific aids and suggestions, and supply it to all lodges, and that he maintain a continuous study of this subject, revising and adding to the program as new and better techniques are developed.

7. That a more extensive distribution and use of the booklet "Manual for Officers and Committeemen" be secured among our Subordinate Lodges.

8. That the Grand Secretary be authorized to prepare and distribute gener-

ally a manual to aid Subordinate Lodges in the successful management of clubs.

9. That the State Associations Committee conduct a study of methods of aiding new lodges, and make recommendations.

10. That special attention be given to the formation of lodges in the suburbs of

metropolitan areas throughout the country.

11. That an Emergency Charity Fund of \$50,000 be created to permit prompt and effective relief in time of disaster.

12. That the unexpended balance of funds raised through the special flood relief appeal last year be earmarked for the Emergency Charity Fund.

# THE GRAND SECRETARY

IN HIS ANNUAL REPORT, Grand Secretary Lee A. Donaldson particularly stressed the problem of membership in the Order, which as of March 31, 1956 was 1,173,494, as compared to 1,149,613 at the close of the previous year, and offered several important thoughts and suggestions, which we quote in their entirety from his Report.

## Membership

"Again this year no intensive campaigns were waged to increase our membership. Therefore, the net gain of 23,881 achieved represents a natural and healthy growth. It came about through the initiation of 85,722 and the addition of 12,522 by dimit and 8,151 by reinstatement. In the same period 82,514 were lost through deaths, dimit, expulsions, or dropped for non-payment of dues.

"The two disturbing factors in connection with membership are the perennial problem of lapsation as well as the fact that our gains are coming primarily from new lodges.

"A major effort was made this year to decrease the number of members dropped for non-payment of dues, but despite all these efforts the percentage of those dropped remains about the same. However, without Grand Exalted Ruler Walker's Membership Control

## Membership By States—1956

| State            | Membership | State  | Membership |
|------------------|------------|--------|------------|
| Ala.             | 7,386      | Nebr.  | 16,109     |
| Alaska           | 7,827      | Nev.   | 4,446      |
| Ariz.            | 15,862     | N. H.  | 5,764      |
| Ark.             | 2,952      | N. J.  | 36,882     |
| Calif.           | 116,855    | N. M.  | 8,406      |
| C. Z.            | 1,296      | N. Y.  | 72,385     |
| Colo.            | 29,560     | N. C.  | 11,810     |
| Conn.            | 20,315     | N. D.  | 13,312     |
| Del., Md., D. C. | 11,349     | Ohio   | 59,260     |
| Fla.             | 30,903     | Okl.   | 8,185      |
| Ga.              | 19,042     | Ore.   | 45,575     |
| Guam             | 318        | Pa.    | 88,903     |
| Hawaii           | 1,943      | P. I.  | 501        |
| Ida.             | 20,193     | P. R.  | 763        |
| Ill.             | 63,112     | R. I.  | 7,611      |
| Ind.             | 47,275     | S. C.  | 7,132      |
| Ia.              | 28,503     | S. D.  | 9,783      |
| Kan.             | 23,026     | Tenn.  | 10,788     |
| Ky.              | 7,301      | Tex.   | 22,361     |
| La.              | 2,799      | Utah   | 5,207      |
| Me.              | 5,369      | Vt.    | 5,767      |
| Mass.            | 38,845     | Va.    | 13,311     |
| Mich.            | 51,223     | Wash.  | 56,323     |
| Minn.            | 14,985     | W. Va. | 18,951     |
| Miss.            | 3,104      | Wis.   | 27,085     |
| Mo.              | 12,933     | Wyo.   | 11,251     |
| Mont.            | 21,347     | Total  | 1,173,494  |

Program it would have been worse. An alert Lapsation Committee and Lodge Secretary constantly billing and personal-

(Continued on page 38)

## Charitable, Welfare and Patriotic Work

Below is a list of Charitable, Welfare and Patriotic activities in which subordinate lodges are engaged, together with total moneys expended for the same during the lodge year from April 1, 1955, through March 31, 1956:

| Activities                                                           | Amount         |
|----------------------------------------------------------------------|----------------|
| Relief of Members, Widows, Orphans, Dependents, Burials, etc.        | \$ 669,687.92  |
| Summer Outings, Camps and Health Resorts                             | 281,633.65     |
| Cerebral Palsy                                                       | 442,839.97     |
| Crippled Children                                                    | 781,821.53     |
| Medical Aid and Hospitals                                            | 418,307.85     |
| Care of Needy Families, including Thanksgiving and Christmas Baskets | 956,258.41     |
| Elks National Foundation                                             | 187,038.65     |
| Youth Work (except for scholarships, free textbooks, etc.)           | 793,449.75     |
| Scholarships, Free Textbooks, etc.                                   | 255,127.40     |
| Red Cross, Salvation Army, etc.                                      | 333,418.51     |
| Veterans' Relief                                                     | 161,118.92     |
| Miscellaneous                                                        | 1,015,819.86   |
| Flag Day, Constitution Day, Fourth of July, etc.                     | 192,498.99     |
| Total                                                                | \$6,489,021.41 |

The following table shows the amount expended in Charitable and Welfare work by each State and Special Jurisdiction during the period from April 1, 1955, to March 31, 1956:

| State            | Amount       | State  | Amount         |
|------------------|--------------|--------|----------------|
| Ala.             | \$ 50,893.10 | Nebr.  | \$ 71,154.53   |
| Alaska           | 57,494.87    | Nev.   | 43,846.73      |
| Ariz.            | 106,025.03   | N. H.  | 25,160.54      |
| Ark.             | 23,030.88    | N. J.  | 372,300.05     |
| Calif.           | 759,360.15   | N. M.  | 68,889.07      |
| C. Z.            | 5,028.18     | N. Y.  | 420,287.26     |
| Colo.            | 202,788.54   | N. C.  | 123,819.36     |
| Conn.            | 100,733.45   | N. D.  | 47,890.96      |
| Del., Md., D. C. | 46,965.23    | Ohio   | 201,837.30     |
| Fla.             | 221,916.52   | Okl.   | 48,986.16      |
| Ga.              | 272,787.21   | Ore.   | 294,935.83     |
| Guam             | 2,238.78     | Pa.    | 312,840.40     |
| Hawaii           | 6,155.92     | P. I.  | 2,221.71       |
| Ida.             | 112,433.12   | P. R.  | 3,722.79       |
| Ill.             | 349,949.07   | R. I.  | 70,750.91      |
| Ind.             | 164,749.67   | S. C.  | 54,523.19      |
| Ia.              | 71,211.36    | S. D.  | 36,180.61      |
| Kan.             | 74,655.01    | Tenn.  | 71,274.37      |
| Ky.              | 32,687.15    | Tex.   | 163,012.82     |
| La.              | 17,107.65    | Utah   | 78,085.95      |
| Me.              | 19,750.09    | Vt.    | 31,485.30      |
| Mass.            | 312,963.52   | Va.    | 69,958.02      |
| Mich.            | 114,602.84   | Wash.  | 248,123.33     |
| Minn.            | 68,976.38    | W. Va. | 123,288.98     |
| Miss.            | 14,825.63    | Wis.   | 114,795.90     |
| Mo.              | 70,182.16    | Wyo.   | 37,605.29      |
| Mont.            | 72,532.55    | Total  | \$6,489,021.41 |



# Welcome!

# Elks



Where there's  
Life... there's  
**Budweiser®**



**KING OF BEERS**

ANHEUSER-BUSCH, INC. • ST. LOUIS • NEWARK • LOS ANGELES



# Grand Secretary's Report

(Continued from page 36)

ly contacting the delinquents can save many members. A live, active lodge which is doing something worthwhile will also induce the members to want to retain their membership.

"Grand Exalted Ruler Walker in his Report pointed out the loss being suffered by some of the big city lodges located in downtown areas. This is also true of a number of the older lodges; yet there are still a number of fine American gentlemen in every community who ought to be Elks. I know that there

## Dispensations

### Granted by Grand Exalted Ruler William J. Jernick

| Dispensation Granted | Name and Number of Lodge                           | Instituted |
|----------------------|----------------------------------------------------|------------|
| 6-7-55               | Auburn, Ind., No. 1978                             | 6-26-55    |
| 6-6-55               | North Penn (Lansdale), Pa., No. 1979               | 6-27-55    |
| 6-7-55               | Staunton, Va., No. 351                             | 6-29-55    |
| 6-8-55               | Yreka, Calif., No. 1980                            | 6-25-55    |
| 6-10-55              | Huntsville, Tex., No. 1981                         | 6-23-55    |
| 6-10-55              | Houghton-Higgins Lake (Roscommon), Mich., No. 1982 | 6-26-55    |
| 6-20-55              | Somerset Hills (Bernardsville), N. J., No. 1983    | 6-26-55    |
| 6-28-55              | Garland, Tex., No. 1984                            | 10-20-55   |

### Granted by Grand Exalted Ruler John L. Walker

|          |                                    |          |
|----------|------------------------------------|----------|
| 8-22-55  | Erwin, Tenn., No. 1985             | 8-27-55  |
| 8-22-55  | Orange, Tex., No. 284              | 9-20-55  |
| 10-18-55 | Farmington, Mich., No. 1986        | 12-18-55 |
| 10-20-55 | Fayetteville, Ark., No. 1987       | 11-12-55 |
| 11-21-55 | Walterboro, S. C., No. 1988        | 12-16-55 |
| 11-23-55 | Beaverton, Ore., No. 1989          | 12-3-55  |
| 12-5-55  | Lewisburg, Tenn., No. 1990         | 12-12-55 |
| 12-27-55 | Redwood City, Calif., No. 1991     | 2-25-56  |
| 2-13-56  | North Arlington, N. J., No. 1992   | 2-19-56  |
| 2-20-56  | Fullerton, Calif., No. 1993        | 3-17-56  |
| 2-28-56  | Concord, Calif., No. 1994          | 3-24-56  |
| 2-28-56  | Hill City, Kan., No. 1995          | 4-7-56   |
| 3-5-56   | West Covina, Calif., No. 1996      |          |
| 3-6-56   | Belmar, N. J., No. 1997            | 3-18-56  |
| 3-9-56   | Babylon-Bay Shore, N. Y., No. 1998 | 4-8-56   |
| 3-12-56  | St. Helens, Ore., No. 1999         | 4-7-56   |
| 3-20-56  | Winder, Ga., No. 2000              | 4-13-56  |
| 4-11-56  | Paramus, N. J., No. 2001           | 4-22-56  |
| 4-23-56  | Ponca City, Okla., No. 2002        | 5-26-56  |
| 5-7-56   | Bellflower, Calif., No. 2003       |          |
| 5-11-56  | Springfield, N. J., No. 2004       | 5-27-56  |
| 5-21-56  | Roxboro, N. C., No. 2005           |          |
| 5-23-56  | Cranford, N. J., No. 2006          |          |

### Special Note

At the time the 1955 Annual Report of the Grand Secretary went to press, formal report of the institution of eleven Lodges for which dispensations had been granted by Grand Exalted Ruler William J. Jernick had not been received. Dates of institution of these Lodges were as follows:

|                                           |         |
|-------------------------------------------|---------|
| Washington, Ga., No. 1964                 | 4-15-55 |
| West Deptford (Woodbury), N. J., No. 1967 | 4-24-55 |
| Vista, Calif., No. 1968                   | 6-11-55 |
| Tuscola, Ill., No. 1970                   | 5-15-55 |
| Ellenville, N. Y., No. 1971               | 6-19-55 |
| Sweet Home, Ore., No. 1972                | 5-21-55 |
| Hamburg, N. Y., No. 1973                  | 6-5-55  |
| Lake Wales, Fla., No. 1974                | 6-2-55  |
| Trona, Calif., No. 1975                   | 6-25-55 |
| Fairfield, Calif., No. 1976               | 6-18-55 |
| Endicott, N. Y., No. 1977                 | 6-19-55 |

are hundreds of our members who have never proposed a new member and suggest to each of them that he invite one of his friends to affiliate this year. This offers an opportunity to make a worthwhile contribution to the lodge and our Order.

"In the planning for his year, every Exalted Ruler should include all phases of membership. His objective should be to finish his year with his lodge a little stronger numerically. A well-planned, selective membership effort to gain new members as well as a vigorous endeavor to keep the membership paid up could accomplish this."

## United States Securities

Continuing his Report, the Grand Secretary stated that as of May 31st the Grand Lodge holds in its various funds

United States Securities in the following amounts:

|                         |               |
|-------------------------|---------------|
| In the Reserve Fund.... | \$ 629,503.13 |
| In the General Fund.... | 200,000.00    |
| In the Home Fund.....   | 180,000.00    |

\$1,009,503.13

The Reserve Fund bonds shown at a cost of \$629,503.13 have a par value of \$630,000. A United States Savings Bond (Series "K") in the amount of \$20,000 was bought for the Reserve Fund.

## Finances

Current assets of the Grand Lodge are \$1,970,210.70; fixed assets are \$1,209,384.98, making the total assets of Grand Lodge \$3,179,595.68. Brother Donaldson reported Subordinate Lodge assets to be \$265,822,385.25, an increase of more than \$11,000,000 over last year.

# BOARD OF GRAND TRUSTEES

**F**OLLOWING the close of the Grand Lodge Sessions held in Philadelphia last July, the Board of Grand Trustees met and elected Nick H. Feder as Chairman; Arthur M. Umlandt as Vice-Chairman and Approving Member; Horace R. Wisely as Secretary; Ronald J. Dunn as Home Member, and W. A. Wall as Building Applications Member.

As directed by the Grand Lodge, the Board of Grand Trustees procured and presented suitable testimonials to retiring Grand Exalted Ruler William J. Jernick and retiring Member of the Board of Grand Trustees, Fred L. Bohn.

The Board met during the year at the Elks National Home in Bedford, Va., at the Elks National Memorial Building in Chicago, the Hotel Commodore in New York and will meet at the Conrad Hilton Hotel in Chicago during the forthcoming Convention.

## Building Applications

During the fiscal year the Board of Grand Trustees received 137 applications from subordinate lodges requesting approval to purchase, sell, erect new buildings, make alterations or additions to present buildings or to mortgage property. Authorization was granted for alterations or additions to buildings, construction of new homes, including expenditures for furnishings and equipment, in the amount of \$6,618,125.55. The Board also approved the sale or exchange or leasing of property in the amount of \$316,800.

## Elks National Home

One of the chief responsibilities of the Board of Grand Trustees is the direction of the Elks National Home in Bedford, Va., which is under the direct management of Brother Thomas J. Brady. In the

report, the Board particularly praised him for his capable, efficient and friendly administration of the affairs of the Home. The Home has 167 acres of fertile land in the Blue Ridge Mountains with modern buildings and equipment recently appraised at nearly three million dollars. Each Brother has a private room, decorated to his taste, and in addition to a beautiful dining room there is a completely equipped hospital and virtually unlimited recreational facilities.

The average number of residents at the Home during the fiscal year was 283, and the average cost per resident was \$824. The Board reported that the net operating cost for the year was \$152,902.46. This cost was arrived at after taking credit for maintenance payments by the subordinate lodges, as well as maintenance recoveries.

## Grand Lodge Convention Report Next Issue

In our August issue there will be a full news report of the proceedings of the four Business Sessions to be held at the forthcoming Grand Lodge Convention in Chicago from July 9-12, as well as the Opening Public Session on Sunday, July 8th. The coverage will include the election of new Grand Lodge officers and the committee appointments, as well as the reports of the Grand Lodge Commissions and Committees.

In addition there will be a digest of the annual reports of the Elks National Memorial and Publication Commission, the Elks National Service Commission and the Elks National Foundation.



# "FREEDOM'S FACTS" — Reds Rule On



For several months *The Elks Magazine* has been publishing each month extracts from "Freedom's Facts," a publication of the All-American Conference To Combat Communism.

Along with fifty national organizations, the BPOE is a member of the Conference. The excerpts have been run as part of *The Elks Magazine's* editorial program of alerting its readers to the various facets of Communism. The extract which follows is from the current issue of "Freedom's Facts."

The announcement last month of the liquidation of the Cominform did not catch anyone by surprise. The Cominform was founded by the late Andrei Zhdanov and ex-Soviet Premier Georgi Malenkov in 1947 to coordinate the activities of Communist Parties outside the Soviet Union. It partly replaced the earlier Comintern, which was dissolved during World War II to convince the West that the Reds were halting their drive to Communize the world.

The end of the Cominform, likewise, appears to be an attempt to persuade the free world that Moscow is not interested in trying to "export Revolution." Nonetheless, the Reds are making sure that

Party members recognize that this change does not mean any change in the objectives of overseas Communist Parties or in the policy of coordinating their activities with Moscow.

The Party newspaper, "Pravda", on April 18 reported that the end of the Cominform in no way means a weakening of links between the "Communist Parties" which, of course, includes relations between the Communist Party of the United States and that of the USSR.

These Parties are "united by a single ideology of Marxism-Leninism," "Pravda" continued. "An exchange of opinions on urgent problems has always been and will be an indispensable condition for the activity of all Communist Parties."

The homage the Reds in America pay to the Red Bosses in Moscow was proclaimed by U.S. Party Secretary, Eugene Dennis, in the "Daily Worker" of April 16. Dennis wrote, "The Soviet Union is not just another country . . . It is a country where the working class is the ruling class." It is the "pioneer builder of a new world system of socialism."

The death of the Cominform, in fact, demonstrates again that the Red rulers in Moscow reach with their overseas Communist Parties into virtually every country in the free world and interfere outrageously in the internal affairs of those countries. U.S. Reds are not members of a legitimate political party. They are, as the SACB has called them, agents of a foreign power.

## Rod and Gun

(Continued from page 12)

and the like. Only a shower which freshens and colors the water gives these fishermen a chance, and this is a temporary condition. Yet there are a few stream-fishermen who actually prefer this time of year. They enjoy it the most when the going is generally considered to be the toughest. Then they have things all their own way.

This breed of fishermen is what is sometimes known as a purist. He is the dry-fly man. Luckily for the trout, his numbers are small; and, also luckily for the trout, most purists work under a strict code of self-applied conservation. They release most of the trout they take, carefully and with a wet hand, striving not to kill trout but to improve their performance, to take one just a little wiser or under conditions just a little more difficult. Some of these fishermen are motivated by a completely unselfish attitude, doing their part to provide future sport for themselves and for others, but a few undoubtedly release their take out of a feeling of superiority. They know they can take trout where others cannot;

so there is no need to be at all greedy.

Why there are not more accomplished dry-fly fishermen, I don't know. The rules are simple, and the results are certainly satisfying. Possibly they are awed by the dry-fly fisherman's art, but they shouldn't be. It isn't that difficult.

The only real requirement is a certain mastery with a fly rod; that is, it is necessary to learn how to float a fly over a rising fish without disturbing him. If everything suits the trout, he may take it the first time, but the test comes when he doesn't. The most satisfying trout I ever took was not the largest by many pounds—not even the largest on a dry fly. He was a stubborn 19-inch rainbow rising in a slick stretch of water that I worked on for an hour and a half before I hit the right combination. Finally, the seventh fly I tied on was the size and pattern he wanted, and he took it well and deep.

With a fine leader and a well-directed cast, a feeding trout can be cast to many times without "putting him down," but one careless cast that slaps the water too



**Direct Prices & Discounts to Clubs, Churches, Lodges, Schools and All Organizations**

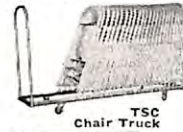

**MONROE TRUCKS**  
For storing Folding Tables and Chairs the easy, modern way. Each truck handles either tables or chairs. Construction of Truck No. TSC permits storage in limited space.

**WRITE FOR CATALOG, PRICES AND DISCOUNTS**

**THE Monroe COMPANY**  
90 CHURCH STREET, COLFAX, IOWA

### NEW HULL AUTO COMPASS

INSTALLS, OPERATES WITH SPARKLING NEW PERFECTION  
Hull—the last word in accurate, dependable auto compass performance—also offers the latest in mounting brackets, for easy, best installation in ANY car.

**New Hull Combination Mount**  
Works as SCREW-DOWN STAND along Lower Windshield Molding . . . Hanging Bracket along Upper Molding or Mirror Foot . . . Vacuum Cup anywhere on GLASS.



At Better Dealers Everywhere, or Write For Free Literature  
**HULL MFG. CO.**  
P. O. Box 246-EE6, Warren, Ohio



**FOUR-COLOR SELECTION**  
*Baconite*  
illuminated \$6.50  
*Streamline*  
non-illuminated \$4.95



### ELKS ROAD SIGNS

Welcome visiting Elks to your Lodge by erecting these signs on main highways into your city.

30" Emblem sign in five colors, vitreous porcelain enamel on steel.

10" x 24" por. enam. plate with 3 lines of lettering available in 2 colors.

**\$29.75 F.O.B. Chicago**

Allow 3 weeks for shipment (We do not supply post)

**RUSSELL-HAMPTON CO.**  
303 W. MONROE ST. CHICAGO 6, ILL.



Say it better . . . Say it forever . . . Say it for less  
U. S. Bronze leadership in quality and artistry is forever impressing everybody everywhere, and low prices keep our customers pleased, too. Write now for new complete FREE color catalog and information — helpful suggestions for honor rolls, awards, memorials, testimonials, for everything. Write to

"Bronze Tablet Headquarters"  
**UNITED STATES BRONZE CO., INC.**  
576 Broadway, Dept. E, N. Y. 12, N. Y.



hard or that drags the fly unnaturally across his feeding station will put an end to it. Sufficient accuracy and delicacy in casting can be developed through a reasonable amount of practice, but, first, the proper tools are necessary.

Since casting is a continuous operation in dry-fly fishing, and since the idea is for it to be a pleasure, the rod must be light; and, in my opinion, it should be made of split bamboo. It is entirely possible to fish a dry fly with rods made of a variety of materials, but there has been nothing devised which for its weight will deliver a fly with the tireless effort of bamboo. Some specialists like very light rods, but for the average a rod eight or eight and one-half feet long and weighing somewhere between three and one-half and four and one-half ounces is ideal.

The line should be tapered. A double-tapered line in a Size HEH or HDH will work well on such a rod. The various forms of fly lines with the heavy belly concentrated well forward, while ideal for distance casting, are less suitable to dry-fly fishing because they are inclined to strike the water too sharply.

The leader as well should be tapered, and where delicacy is important—that is, in bright, clear water or on a quiet pool—length of leader is more important than weight. In other words, sheets of paper should be cut and folded into strips of the length of the leader and the weight of the fly should be distributed over the length of the leader. A twelve-foot leader tapered down to only four pounds than on a nine-foot leader tapered down to two pounds.

Then, of course, the fisherman must have a variety of flies. A trout doesn't know anything about patterns or fancy fly names. He knows only when the artificial is approximately the same size and shape of the natural on which he is feeding. Fortunately, he gets a distorted impression of the floating fly anyway due to the indentations the hackle points make on the water surface. Flies in Sizes 16, 14, and 12 will cover most requirements. A natural Mayfly or caddis fly is a dainty thing, and the most common error fishermen make is using an artificial either too large or too bushy. Wings, by the way, are put on dry flies mostly for the fisherman's benefit. A plain hackle fly of the same general size and shade of the natural will take trout.

So much for the tools. Next comes practice, and the place to practice casting is not in the backyard but on a stream. Work the headwaters and the tributaries. The trout in such places will average smaller than in the main river, but they are willing surface feeders and they don't require a heavy hatch to bring them to the top. Fish in small or relatively shallow water can be tempted up no matter what the hour or how bright and hot the day. The size of a fish is relative to his surroundings anyway.

Where the trout average seven and eight inches long, a nine-inch is a good one, and a twelve-inch is a whopper. In fact, a twelve or fourteen-inch trout

on a dry fly is a good one anytime. A dry fly is not ordinarily the means to produce the big ones, but a fish of this size taken on the surface will supply more fun than one twice the weight taken blind in the depths. And it is occasionally possible to take a really big trout on a dry. All stream trout, no matter how large, feed extensively on insect life. When a heavy hatch is on, no manner of glittering spinning gadget, wriggling worm or shiny minnow could tempt a feeding trout, and this includes the big ones as well as the little fellows. The dry fly fisherman who spots a large trout rising has a better chance of taking him than does another fisherman using anything else short of dynamite.

IN THE COURSE of fishing a dry fly for a long period and on many waters, I have been lucky enough to find a few such big fish; so I know what a floating fly is capable of. I have landed several trout better than four pounds, and one giant, taken on a No. 14 Tup's Indispensable, which weighed six pounds.

But these are the rare ones and by no means necessary to make dry-fly fishing the most fascinating of all forms of fishing. I still get as great a thrill as ever in discovering a twelve-inch dimpling the surface in a glassy meadow stream. There are always practical problems to work out: what insect he is rising for, how to approach him with the least danger of being detected, and where to cast so that the current will take the fly to him without drag and without putting the line over him. It is easy to make a mistake, but if the problem has been figured out properly, there is a good chance of getting a rise. And if the cast is made correctly—that is, shot at an imaginary point a couple of feet above the surface of the water so that the line can extend itself and drop gently to the water—the fly will hang for a moment in the air, then float to the surface like down. Such a cast can be made time and again, with various flies, without disturbing the wari-

est trout as he floats in the stream. And a dry-fly fisherman so engaged soon becomes a part of the scenery. He sees and hears things that other fishermen miss: a deer crossing the meadow; a coon reaching blindly among the rocks along shore for crawfish or hellgrammites, his foreleg submerged to the shoulder; a hen black duck swimming around the bend with her family strung out behind as if on parade. Then, suddenly, the trout takes the fly, and the calm is shattered. He races across the pool and comes out in a sparkling leap and splashes back in the pool. He is several inches longer than his rise indicated, and you hope the hook is well set. It is a temptation to force the battle, but you know that the best way to lose him is to hurry him. He takes line, gives a little, and takes it again. Finally, after several tense minutes, he comes in on his side, fought out to the last tail beat. It is easy to release such a trout because he has done his part so well.

Then evening comes and the Mayflies commence their dance. A pool that in bright sunlight would seem to be completely devoid of fish comes bubbling to life. Little trout splash in the shallows and at the tail of the pool, larger ones toward the head and along the main current. Things happen fast. It is all over in a few minutes, the beginning of the rise and darkness, but it is a wonderful time of day, the most absorbing a trout fisherman can know. And a dry-fly fisherman has everything in his favor at this moment. All of the trout are showing, and by their rises he can select the best fish in the pool and concentrate on him. With enough practice behind him—and a share of good luck—he may take him. In any case, he will discover that it has become very dark in a very short time. And if he has failed to take the big one, he at least has learned something that will help him the next time the Mayflies dance. And he has had fun, as much as any man with a rod and reel can have, which is a lot.

## SCRANTON, PA., LIBRARY GETS ORDER'S HISTORY

Officials of Scranton, Pa., Lodge present two copies of "A History of the Order of Elks" to the Scranton Public Library. Left to right are the lodge's 64-year Secretary William S. Gould and Treasurer Sam Druck, Librarian Joseph Myers and Exalted Ruler Karl H. Strohl.





# Deal or Die

(Continued from page 5)

has the background and experience to know what he's doing."

DeWitt's description fits Frank Lane, the new boss of the St. Louis Cardinals. It also wraps around George Weiss, DeWitt's own boss and, last but not least, DeWitt himself. And in Branch Rickey's heyday the Mahatma fitted that description as though it had been especially scripted for him. (Speaking of heydays, the long shadow of the man who built the Cardinals, and then the Dodgers, again seems to be falling over the National League as years of planning a new Pirate team show the results of this master judge of ball players.)

Frank Lane dealt and traded the Chicago White Sox from a lowly second-division estate to a red-hot contender in a short time. A restless wanderer, given to prodigious long-distance phone calls at early hours from far-flung hotel suites, Lane collected such performers as Billy Pierce, Minnie Minoso and Nels Fox in deals.

Lane fulfilled DeWitt's requirements of background and imagination and ability to absorb advice. The last he does in a singular way: He's not only a pal of **DeWitt's** but also a pal of **George Weiss**. **DeWitt's** description fits **Frank Lane**, the new boss of the **St. Louis Cardinals**. It also wraps around **George Weiss**, **DeWitt's** own boss and, last but not least, **DeWitt himself**. And in **Branch Rickey's** heyday the **Mahatma** fitted that description as though it had been especially scripted for him. (Speaking of heydays, the long shadow of the man who built the Cardinals, and then the Dodgers, again seems to be falling over the National League as years of planning a new Pirate team show the results of this master judge of ball players.)

**L**ANE doesn't know how many papers there are in the United States. Chances are, however, he's probably read every one of them at some time. He cheerfully admits to reading sixty, repeat 60, sports sections EVERY day.

This accounts for practically all of Frank Lane's reading, usually all post-midnight, too. His staff prepares it for him, like some high-ranking general, ringing items in red crayon. Lane's restless eye, however, travels beyond the red boundaries.

"I consider reading the papers an unbreakable part of my routine," says the Cardinals' general manager. "If I miss the previous night I'll get up at 5 a.m. to get it in before the start of my next day's work. I read up to 3 a.m. and," he smiled, "I don't fall asleep reading, either."

Lane reads the sports pages like some skilled cryptographer who has broken the enemy's code. The standard box score unfolds before him, revealing practically the entire strategy of a rival club in some distant game. Major-league box scores are not his only fare, however. He pores over the minor league results, the semi-pros, the American Legion contests. Little clues are stashed away in his mind for future use when he deals, drafts and juggles the Cardinals' talent picture.

"You'd be surprised at the seemingly unimportant ways the sports pages serve me. Even down to signing a green kid," he explained.

"A boy writes in from some place in



More . . . and more . . . and more  
ECHO SPRING answers the call  
for truly smooth

Kentucky Straight Bourbon

No other bourbon ever came  
Kentucky Bourbons: For a  
price lower than most other  
Echo Spring comes to you at  
a price lower than most other  
Echo Spring comes to you at  
a price lower than most other

STRAIGHT BOURBON WHISKEY... BE PROOF... ECHO SPRING DISTILLING COMPANY, LOUISVILLE, KY.

# FREE

30 DAYS SUPPLY  
Safe High-Potency Nutritional Formula

# VITAMINS

MINERALS AND AMINO ACID



25 proven ingredients -  
11 Vitamins (including  
Blood-Building B12 and  
Folic Acid), 11 Minerals,  
Choline, Inositol, and Methionine

**NOW YOURS FREE**



RETAIL  
VALUE  
\$5.00

**Each Daily C. F. Capsule Contains:**

|               |                  |
|---------------|------------------|
| Vitamin A     | 12,500 USP Units |
| Vitamin D     | 1,000 USP Units  |
| Vitamin C     | 75 mg.           |
| Vitamin B1    | 0.5 mg.          |
| Vitamin B2    | 2.5 mg.          |
| Vitamin B6    | 0.5 mg.          |
| Vitamin B12   | 1 mcg.           |
| Niacin Amide  | 40 mg.           |
| Calcium       | 4 mg.            |
| Pantothenate  | 2 I.U.           |
| Vitamin E     | 0.5 mg.          |
| Folic Acid    | 75 mcg.          |
| Calcium       | 30 mg.           |
| Phosphorus    | 0.04 mg.         |
| Iron          | 0.45 mg.         |
| Cobalt        | 0.5 mg.          |
| Copper        | 0.1 mg.          |
| Manganese     | 0.075 mg.        |
| Molybdenum    | 2 mg.            |
| Iodine        | 0.5 mg.          |
| Potassium     | 3 mg.            |
| Zinc          | 31.4 mg.         |
| Magnesium     | 15 mg.           |
| Choline       | 10 mg.           |
| Bitartrate    |                  |
| Inositol      |                  |
| dl-Methionine |                  |

Compare this formula with any other!

Yes, we want to send you FREE a 30-day supply of high-potency Vitaflex C.F. Capsules (a \$5.00 value) so you can discover for yourself how much healthier, happier and peppier you may feel after a few days' trial! Each capsule supplies your body with well over the minimum adult daily needs of the 11 important vitamins, plus 11 minerals, choline, inositol and amino acid.

Potency and Purity Guaranteed  
You can use these Capsules confidently because strict U. S. Government regulations demand that you get exactly what the label states - pure ingredients whose beneficial effects have been proven time and time again!

Amazing New Plan Slashes Vitamin Prices in Half  
With your free vitamins, we will send you complete details of an amazing new plan that provides you with a 30-day supply of vitamins every month for just \$3.00 - 60% less than the usual retail price. But remember - you're not obligated to buy from us 29 or more times. The supply of free capsules is limited - so mail yours today!

VITAFLEX CORPORATION  
43 West 61st St., New York 23, N. Y.

VITAFLEX CORP., Dept. 300  
43 West 61st Street, New York 23, N. Y.

Please send me free a 30-day supply of the proven VITAFLEX C.F. (Comprehensive Formula) Capsules, and full information about the VITAFLEX plan. I am not under any obligation to buy any additional vitamins, and after trying my free sample supply, I will be given the opportunity to accept or reject the benefits and substantial savings offered by the VITAFLEX Plan. In any case, the trial month's supply of 30 VITAFLEX Capsules is mine to use free. I ENCLOSE 25¢ (coins or stamps) to help pay for packing and postage.

Name .....

Address .....

This offer is limited to those who have never before taken advantage of this generous offer. Only one trial supply per family.



the sticks that he'd like a tryout. Maybe it isn't convenient to send a scout out to look him over. I ask him to send some box-scores from the papers showing the games he's played in. If he does it means that he's played at a level sufficiently high so that the local newspaper recognizes the game or the league. The box score itself will tell a great many things. If the boy has batted third or fourth in the lineup it will show me the club he's been playing with has a high estimate of his value as a hitter.

Sometimes the investments wrapped up in deals would stagger the minds of people punier than those involved in baseball. Maybe that's why few staid financial institutions will make loans to baseball clubs without the standard collateral required of a fellow seeking a loan of a few grand to finance the purchase of a car. Baseball people think it a routine proposition to make a deal involving \$250,000 worth of ball players on an overall investment of three or four million. Try that ratio some time on one of your captain-of-industry friends.

Bill DeWitt recalls rather vividly the check which crossed his desk a decade ago when he was general manager of the St. Louis Browns. It had six figures. The first was a "3".

"We got \$310,000 from the Red Sox for Vern Stephens and Jack Kramer," said DeWitt. "And we got seven players.

"It was actually a price tag of \$300,000," he explained. "But they threw in another ten grand so we could buy a couple of minor league players from the Red Sox' Louisville farm."

Why were the Browns able to extract this amount from the Red Sox for two players? It was merely a case of there being a tide in the affairs of Boston which DeWitt was able to recognize and to capitalize on swimmingly.

The Red Sox had won their first pennant the previous year in twenty-eight seasons. They had won 104 games, had carried the Cardinals to seven games in the '46 World Series. Then they proceeded to fail in '47, winning 21 fewer games than they did the previous year. Seldom has a club, before or since, been in a more receptive mood with respect to writing a fat check for players deemed capable of helping.

Actually the Browns, who incidentally could use the money, realized a total of close to \$500,000 on the deal. There were some pretty good names among the seven players coming their way from Boston—Ed Pellagrini, Pete Layden, Roy Partee, Jim Wilson, Al Widmar, Don Palmer and Joe Ostrowski. They figured in all kinds of subsequent deals, going and coming, with always that little extra something being thrown in to sweeten up the pot a little for the Browns, who were languishing at the gate.

One of these players, Joe Ostrowski, a scholarly-looking pitcher, was to figure in one of those beef-up-the-Yankees maneuvers which have had such a consider-

### THE ELKS MAGAZINE IN NEW OFFICE SPACE

On May 1st, The Elks Magazine moved its offices to 386 Fourth Avenue, New York 16, N.Y., after having been located for thirty-five years at 50 East 42nd Street. The move was made in order to obtain larger space and also to better the coordination of the various departments by placing them on one floor. We would appreciate it very much if readers will take note of this change of location and address all communications to 386 Fourth Avenue.

able part in the startling successes enjoyed by the New Yorkers in the past decade. Every year, for the past half-dozen seasons, either an in-season or an off-season deal has been made to strengthen the New York club. Ostrowski happened to figure in the one in which he and Tom Ferrick, now a coach with the Cincinnati Redlegs, came from the Browns to lend considerable aid to the Yankees' '50 pennant drive.

Weiss had been dealt a failure a couple of seasons before in Fred Sanford, a Browns righthander who cost the Yankees \$100,000 and three players, one being Sherm Lollar, currently the White Sox' No. 1 catcher. The idea was that Sanford, able to win a dozen games with a club like the Browns in '48, could probably win two dozen with a club like the Yankees. Unfortunately it didn't quite work out that way.

Sanford was still around enjoying the first-division scenery when Weiss went back to the Browns grab-bag again. Again Weiss went for his checkbook and his reserve talent. The Ferrick-Ostrowski duo dented him to the tune of \$50,000 plus a couple of pitchers, Don Johnson and Duane Pilette, an infielder, George Stirnweiss and an outfielder, Jim Delsing. This time it wasn't money and talent down the drain. The Yankees won the '50 flag by three games. The new pair, principally through Ferrick's efforts, accounted for nine Yankee pitching victories.

**E**VERY year in the last half-dozen there's been a new face, or faces, in the Yankee pitching picture as the result of a deal. Unobtrusive in public, Weiss is apparently a master in a hotel room with a rival general manager. Players or money mean nothing in his drive for the man he thinks will put the Yankees across in any given season.

Fortunately the Yankees do well enough at the gate so that money isn't a prime consideration. The Yankee scouts do well enough in beating the byways so that there seems always to be an unending stream of talent available to be dealt off.

In 1951 Sanford, Ferrick and Bob Porterfield, one of Weiss' big personal

favorites incidentally, went to Washington for Bob Kuzava, a lefthander. Another \$50,000 Yankee check wound up in the outgoing mail basket, too.

Kuzava had been a 3-3 performer that year up to that moment with the Senators. With the Yankees he perked up, rang up an 8-to-4 record. He aided considerably in the over-all work of beating back Cleveland's considerable challenge.

In the closing days of the '52 campaign the Yankees thought it would be nice and handy to have a fellow like Ewell Blackwell around for the 1953 drive. Might even help in the closing moments of the '52 race, too. So they gave the Redlegs Johnny Schmitz, Ernie Nevel, a couple of outfielders, Bob Marquis and Jim Greengrass, and a check for \$35,000.

That proved a pretty expensive deal. Blackwell was credited with a total of three victories as a Yankee before quitting for good.

But meanwhile another deal was panning out for the Yankees. Johnny Sain was, for one reason or another, unattractive to the other clubs in the National League when the Boston Braves figured he just didn't have it any more. The Yankees thought he did, had backed up their opinion with \$50,000 and a pitcher, Lew Burdette, late in the 1951 campaign. Sain won a total of twenty-five games for the New Yorkers in the next two seasons, was a big factor in two pennant drives.

Actually, only a starry-eyed Fauntleroy would fail to recognize the gambling aspects of all baseball deals. Weiss still takes tremendous pride in his deal for Joe DiMaggio more than twenty years ago but what if the generally accepted report on DiMaggio's knee had proved true, that he actually was a damaged minor league star and nothing more?

How about the five players Weiss gave to the San Francisco club just for an option to buy DiMaggio for \$25,000 the following year? Supposing the doctor hired by the Yankees to examine DiMaggio quietly in Los Angeles had been proved wrong instead of the other medicos?

Or, to update the problem slightly, supposing the skull fracture Preacher Roe had suffered in an off-season scuffle when he was with the Pirates was to effect him permanently instead of for only a few seasons? Here again there were two schools of medical thought. Some of the doctors, big ones too, were saying Roe would be lucky just to be walking around in a few years let alone pitching in the big leagues.

So Branch Rickey took a daring step, dealt off the aging Dixie Walker, Hal Gregg, a wild righthander, and Vic Lombardi, a little lefthander, for Roy and Billy Cox, an infielder who returned considerably shaken from his World War II experiences. A third player, Gene Mauch, was thrown in by Pittsburgh.

Roe went on to win ninety-three games for Brooklyn, became something of a local legend which even his subsequent



spitball confessions didn't dim too much. Cox was a vital part of several pennant drives. The men Rickey dealt off to Pittsburgh lingered for a season or two, then disappeared.

Rickey found a tremendous market for his surplus talent in Pittsburgh when the new post-war owners took over. He discovered some real babes-in-the-woods had taken charge, important men outside baseball whose bank balances were matched only by their inability to judge baseball talent.

More than a half-million in cash was to pass from Pittsburgh to Brooklyn, with Rickey taking his contractual cut on every sale, before the lode was to run out.

There was one instance where the Mahatma's sales persuasion was almost unbelievable. He had disposed of Stan Rojek, a surplus shortstop, to Pittsburgh and Rojek, an able-enough young man, flashed impressively in a few games. Now the Pittsburgh officials who had okayed the deal for perhaps \$80,000 or \$90,000 was in conversation with another baseball man. The Pittsburgher, incidentally, was a tough-minded individual and a powerful force in the nation's post-war political picture. About baseball he knew a lot less than a lot of people.

"You know," he confided, "I think I did pretty good in getting Rickey to sell me Rojek. Right now I wouldn't trade him back to Brooklyn for Pee Wee Reese."

"Why don't you wait until Rickey asks you?" was the tart rejoinder.

Thirty or forty years ago you could actually buy a pennant. Today all you can do is gamble, although admittedly there was an element of chance even in the days when there were no trading deadline restrictions. The Giants, under John McGraw, were notorious for picking up a player from another club for a wad of cash to help in the last few weeks of some scorching pennant race. There were other clubs, too, that waved a late-August check under the nose of some have-not until that club succumbed.

Today there are all kinds of restraints and balances designed to help even matters. They do somewhat in the form of trading deadlines, no-recall dates, etc., and the second-division denizen has a chance of getting help earlier in the race as the big club shops for insurance before the June 15th mark.

Actually, June 15th is but one of several dates which baseball traders must keep in mind. There is an important milestone which precedes it by a month—cut-down date. That's when the squad must be pared, from 40 to 25, either through options, sales, or outright releases.

After June 15th the players you would like to deal for or deal off your own club have to be offered to the clubs in less fortunate circumstances, standings-wise, than the two dealing clubs. In other words, the last-place club gets first crack at the offering, then the seventh, and so

on, upward until the clubs interested in dealing are reached. And if you want to deal or sell a player into the other major league the same from bottom-to-top progression exists in BOTH leagues.

Another date on the executive's calendar is July 31, last opportunity to recall players optioned to minor league clubs. After that they must remain where they've been sent until the season ends and their club is no longer involved in any kind of play-off. This is comparatively recent legislation introduced a few years ago to prevent the minors from resembling some monstrous bus terminal with players gypsying around without even bothering to unpack. It was a small bone thrown the minor-league operators supposed to help maintain fan interest in a comparatively-stable team.

**A**FTER midnight of Aug. 31 the major league clubs are permitted to operate a larger pumpkin capable of holding 40 players again, although their eligibles, in the event the club reaches the World Series, have to be named at this particular time before the reserves are brought up.

Then on Oct. 15 a freeze sets in on all minor league rosters and this holds until the draft in the first week of December. That's to help the major-league clubs draw their plans to draft talent they think will help them from the minors.

Greatest plum, of course, in the history of the draft was Hack Wilson, acquired by the Chicago Cubs off the Toledo roster in 1925. Wilson had been optioned to Toledo by the Giants, hit .343 there. Why did the Giants let him go for the then-draft price of \$7,500? Simply because someone committed a grievous clerical error and completely forgot about Wilson who went on to become one of the Cubs' all-time greats.

Mistakes aren't confined to one club, of course. Wilson had a great first year with Chicago and perhaps he dazzled someone in the front office so much that he caused him to become a little confused. That same Cub organization permitted the Cardinals to acquire Grover Cleveland Alexander off the Chicago list for the waiver price. Alexander went on from there to help the Cards win the National League pennant that year. He then proceeded to beat the Yankees twice in St.

## Now! Only With Maico! Wear Newest Hearing Glasses

with nothing in the ear!

Now you can wear full powered Maico hearing glasses with nothing in the ear. These are not unsightly glasses with big, bulky bows, but the style you are more than likely wearing right now! In fact you may use your present glasses . . . yet this idea is not merely an attachment. Ideal for conductive type hearing losses. For complete information on remarkable new way to correct a hearing loss inconspicuously, write for free booklet "How to Choose, Use Hearing Glasses".



L. A. WATSON

**MAICO** Dept. 418, 21 North 3rd St.  
Minneapolis, Minn.  
Please send free booklet.  
Name.....  
Address.....  
City..... State.....

## HUNDREDS OF IDEAS

### for BRONZE PLAQUES

FREE illustrated brochure shows hundreds of original ideas for reasonably priced solid bronze plaques—name-plates, awards, testimonials, honor rolls, memorials, markers.

Write For FREE BROCHURE A For trophy, medal, cup ideas ask for Brochure B.

INTERNATIONAL BRONZE TABLET CO., INC.

Dept. 40—150 West 22 St., New York 11

## ★ Midwest CADDIES

For easier, faster handling of

### FOLDING CHAIRS AND TABLES



A style and size for every need.

- Saves time!
- Saves effort!
- Reduces noise!

Moving and storing of folding chairs and tables becomes a pleasure with a MIDWEST CADDY.

Write for FREE catalog

Midwest FOLDING PRODUCTS SALES CO. DEPT. 32G ROSELLE, ILLINOIS

**earn**  
**4 3/4 %**  
CURRENT RATE PER ANNUM PAID QUARTERLY

MAIL FUNDS TO DEPT. 6

## FIRST WESTERN SAVINGS AND LOAN ASSOCIATION

118 South Fifth Street

Las Vegas, Nevada

BART LYTTON, President

## SAVINGS ACCOUNTS BY MAIL

Earn more on your savings account safely. Handle all transactions by mail.

Air mail postage prepaid, Funds postmarked by the 16th earn from the 1st.



Louis's first World Series championship. Rogers Hornsby was the field leader of that Cardinal club, a tremendous hero. Yet the Rajah was dealt off to the Giants that same December for Frank Frisch and Jimmy Ring. It was almost as much a stunner to the Card fans of that era as had been the sale of Babe Ruth by a strapped Red Sox organization to the Yankees a half-dozen years earlier.

The price for Ruth had been \$100,000 but what wasn't revealed until much later was that the Yankees had taken the \$350,000 mortgage on Fenway Park. An arrangement like that would, of course, be out of the question in baseball today but things, as indicated earlier, were a little looser on and off the field thirty or forty years ago.

Fans still get mad at the sale of a favorite, but not with the same intensity. When Enos Slaughter was dealt off by the Cards to the Yankees for a couple of outfielders including Bill Virdon, and a pitcher, Slaughter wept. Some nasty things got into print about base ingratitude, etc.

But when Slaughter was dealt off a year later by the Yankees to Kansas City there wasn't a moist eye in the house. So the indestructible Enos proceeded to prove himself the player of the year for the new Athletics.

After the '47 season Bill Veeck, who regarded Lou Boudreau's managerial ability in Cleveland with something less than awe, got to talking with Bill DeWitt about the possibility of a trade involving Boudreau and Vern Stephens. News of it got around in Cleveland. The papers hopped on it. Veeck, then the Cleveland

club's president, was hung in effigy. Straw ballots showed an overwhelming sentiment that he be packed off to some desert island.

Boudreau stayed. He stayed (a), to lead the Indians to a World Series championship the following year and (b), to gain Most Valuable Player honors in the American League. However, Veeck never did change his opinion of Lou's managing.

**T**RADES, of course, are always exciting no matter who goes in the deal, a fact which probably stems way back to the time we used to wonder what would turn up in the latest box of crackerjacks besides crackerjacks. Trades, too, have served as a sounding board for some of baseball's more entertaining personalities. Where but in baseball could you trade a man for a turkey dinner and not incur the wrath of the neighbors? Where but in baseball could you trade a catcher for a radio announcer? Where but in baseball could a fellow, once up in the majors but now bumping along on the bottom, as represented by D ball in the Mountain States Leagues, complain plaintively, "They traded me for a hound dog, then they shot the dog?"

All these trick trades, and more, are documented. So is the fact that the old Baltimore Orioles acquired Lefty Grove by offering to pay for the erection of an outfield fence around the ball park of the minor league club which owned Grove.

A deal must represent a drastic change in the life of the player or players involved. It represents an uprooting, a change, re-adjustment. Sometimes it is

cause for weeping; other times it represents unparalleled opportunity after years of semi-public burial with a second-division club. It opens new financial vistas in the form of World Series melon slices, an opportunity to pick up an extra couple of hundred just for mentioning the kind of cigarette you smoke, or for wearing a funny hat for a few minutes on TV.

It also represents a turn in the road, a turn in the thinking of the players involved, particularly if he's getting up there in years. A decade ago Billy Herman, drawing to the end of a distinguished career as a National League infielder, was advised in the last week of the season that he was being traded by Boston to the Pirates. It was a six-player deal. Herman was informed that he would be going over as player-manager. The Pirates were definitely on the upbeat after the War and Billy scarcely bothered to conceal his joy.

"Who's going with me?", he asked. "Whitey Wietelmann and Elmer Singleton," was the answer.

"And who's Boston getting?", asked Herman.

"Oh," said the Boston front office man, "we're going to get Stan Wentzel, Hank Camelli and Bob Elliott from them."

Herman's jaw dropped. "Bob Elliott," he exclaimed, "they've traded away HALF MY BALL CLUB!"

Herman never won any medals managing but he could have qualified for some crystal-ball prize with the last crack. Elliott wound up the Most Valuable Player in the league the following year at Boston.

## For Elks Who Travel

(Continued from page 21)

country homes. Some of the solid color alpaca things, and especially the vicuña which is illegal but available nonetheless, make fine bed covering, or, if you prefer, the most invitingly soft rug a barefoot ever trod upon.

The restaurants of Lima are sophisticated to an extent, and the service is as artful as Europe or as European-trained staffs of America's better inns. Aside from typical international fare, you can, with some intrepidity, dip your spoon in local Indian fare. The most common tidbit is the *anticucho*, which is a string of pieces of beef heart stuck on green bamboo spears and toasted over a charcoal fire. The sauces and dips are as hot as the concoctions of Mexico, and if someone offers you a tumbler of local corn likker, called *chicha*, *prenez garde!* The habitual drink in the posh environs of hotels is the *pisco sour*.

With the retirement of one Juan Domingo Peron to the beaches of Panama, Argentina has, I'm sure, become a more tolerable place in which to live. Buenos Aires is a city of immense beauty and cosmopolitan flavor, but it was disfigured

during the reign of Peron with the usual cliché trappings of dictators—signs, exhortations, statues, busts, and lists of the fine deeds of "The Man" and the late Eva Peron. With the city cleaned of those decorations, B.A. emerges as a Paris of the southern hemisphere. It has broad, tree-bordered avenues, magnificent parks, fine old homes that remind one of the avenues that lead off the Arc de Triomphe in Paris.

Here, too, the shopping is wonderful and the eating is probably the best in South America. Leather is the best buy, and you can find a magnificent assortment of suitcases, attaché cases, handbags, travel kits, and even shoes.

I think, however, the greatest thrill of all in Buenos Aires, for trenchermen especially, is to invade one of the better steak houses and order the biggest side of beef in the house. The cost for a two-inch thick steak will rarely be more than one dollar, and a full-sized bottle of local wine, which is extremely good, might prove to be another dollar. New York prices in comparable surroundings are running about five or six times that for steak and a good four times that for wine.

Anybody in a hurry to repair to Buenos Aires, in view of these inducements,

might inquire of Pan American, which makes it south by way of Caracas and Rio, or Panagra, which comes down swiftly by way of Panama, Lima, Santiago and then across the Andes to B.A.

Rio is another story, being neither like Buenos Aires, nor Lima nor Santiago. To me it is reminiscent, in its big sun-washed way, of Miami, and sometimes of Nice along the French Riviera. There is the great graceful curve of Copacabana Beach with its famed mosaic sidewalks, and bordering the beach all the way the pastel buildings all hung with terraces with magnificent views of the South Atlantic. Rio seems made for fun, and it is only proper, I guess, that it has a wide selection of night clubs and some torrid shows based on the terrific rhythms of Brazil, a combination of the Latin and the African. Nightlife is expensive in Rio, and food isn't the buy that it is down in Chile and Argentina. Nor can I say too much for the shopping, which is limited to aquamarines, should you fancy them, and aquamarine-colored butterflies, should you fancy them. But Rio has weather and Rio has beach, and Rio has the samba and Sugar Loaf, and it never seems to take life too seriously. That's bad?



# ELKS NATIONAL FOUNDATION

*"The Joy of Giving"*



Tangible evidence of the great good the Elks National Foundation is doing in the field of cerebral palsy is shown in this picture of Lester M. Brower with an athetoid cerebral palsied child learning to feed himself. The photograph was taken at the Iowa Hospital School at the University of Iowa, Iowa City, Ia. Mr. Brower was the recipient of a \$1,800 grant from the Foundation, which enabled him to take a course in clinical treatment, as a result of which he is now a Registered Occupational Therapist in the Iowa Hospital School.

Robert Battle of Nashville, Tenn., has proved to be a young man of diversified talents and recently won the \$500 weekly award on Ben Grauer's "The Big

Story" TV Program. In 1946 Mr. Battle received an Elks National Foundation Scholarship, the first to be allocated in Tennessee.

Helen Delich, first prize winner in the Girls' Division of the Elks National Foundation "Most Valuable Student" contest in 1941, has made valuable use of the help that the Foundation extended to her to further her education. Miss Delich is with the Baltimore "Sun", and not only is maritime editor, but also conducts a weekly TV program. Recently she was honored by the Advertising Club and the Women's Advertising Club of Baltimore as "Woman of the Year" and was guest at a luncheon attended by 215 persons at the Emerson Hotel.

Congressman Edward A. Garmatz read the tribute that the Baltimore "Sun" paid Miss Delich on the occasion of the award into the "Congressional Record".

"I always will feel that the B.P.O.E. gave me the initial boost so sorely needed to have a career. My thoughts often are with you and the organization, and I thank you so much," wrote Miss Delich recently to Past Grand Exalted Ruler John F. Malley, Chairman of the Foundation.



James E. Parker of Rock Hill, S. C., Lodge has put forth one of the most outstanding individual efforts in the Order this year on behalf of the Elks National Foundation. As Chairman of the Foundation Committee of Rock Hill Lodge, Brother Parker enrolled 430 members who are contributing to the Foundation, each of which has pledged \$100 either in a lump sum or by paying \$10 per year for 10 years.

However, Brother Parker is by no means satisfied with that enrollment and hopes by next year to bring the number of Participating Members at Rock Hill Lodge to 500. Grand Exalted Ruler John L. Walker forwarded the photograph above to us because he is so deeply appreciative of the efforts that Brother Parker extended to make his Elks National Foundation program this year the great success that it proved to be, with the highest contributions ever received in one year by the Foundation. In the photograph, Chairman Parker is shown fifth from the left in the dark suit and he is surrounded by a group of pleased Rock Hill Lodge contributors.



**Write your own success story**

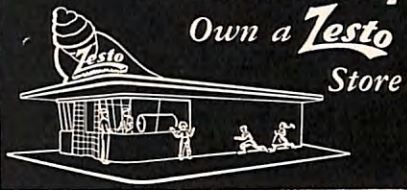

Own a Zesto Store

There's a lot of satisfaction in owning a business of your own. Even more satisfying when that business begins to grow and prosper through your own efforts. Owning a Zesto Dairy Confection store can bring you this thrill of success. More than that, you'll quickly realize a substantial profit on your initial investment.

If ownership alone appeals to you, Zesto stores are good investments. You own the land and the building. The store is leased to another party to operate. You still get a healthy return on your investment. Write today for free, information-packed, illustrated brochure.

**ZESTO, Dept. A, Rockton, Illinois**

## Minstrels & Revues

Organizations make huge profits by using our services. We supply Director, Costumes, Stage Settings, All Scripts etc. Everything furnished. Lowest fees.

**GORDON KEITH PRODUCTIONS INC.**  
28 E. Jackson Blvd., Chicago 4, Ill.



New 4-STYLE Christmas Assortment —24 Tall Slim, Oblong Slim, Square & Petite Cards all in 1 box!

## 168 EASY WAYS TO MAKE EXTRA MONEY

For Yourself or Your Group  
Make \$50, \$75, \$100—more!  
Show friends amazing value Christmas, All Occasion greeting card assortments, gift wrappings, novelties. Profits to 100% Bonus. Write today for Free Trial outfit of Feature boxes on approval. 74 FREE Samples Personal Christmas Cards, Stationery, Fund Raising Plan.

**NEW ENGLAND ART PUBLISHERS**  
North Abington 761, Mass.

## 5% ON SAVINGS

- Send your check Today!
- Or, write for free details
- Accounts opened by 15th of month earn from 1st
- ASSETS OVER \$8 MILLION

## SILVER STATE SAVINGS

& Loan Association  
Dept. EM-7, Las Vegas, Nevada

# Law!

## STUDY AT HOME

We guide you step by step—furnish all text material, including 14-volume Law Library. Training prepared by leading law professors and given by members of the bar. Degree of LL.B. Low cost, easy terms. Send for valuable Free Book, "Law Training for Leadership," today.

LaSalle Extension University, Dept. 7323 L, Chicago 5, Ill.  
A Correspondence Institution



# TRAVELGUIDE



Cedar Cove on Rice Lake, Harwood, Ontario, Canada, owned and operated by Mr. and Mrs. John D. Dougherty of Grove City, Pa., is a family resort boasting of some of the best catches of muskellunge, pickerel, small mouth bass and large mouth bass in the area. For those who wish to combine a restful family vacation with some of the best fishing ever, we recommend Cedar Cove. Only 75 miles from Toronto, it offers modern new cottages and all sports for the family at moderate rates. A post card will bring you all the details.

★ ★ ★

*In 1957 Virginia and the nation will join in a year long, state-wide observance of our Country's birthday—the 350th anniversary of the first permanent English settlement in the New World at Jamestown, Virginia, in May, 1607. The festival will be centered around the historical sites of Jamestown, Williamsburg and Yorktown—Virginia's and the nation's triple shrine, all within a radius of nineteen miles between the James and York*

*rivers. The Festival is being planned by authorization of President Eisenhower and Congress and of Governor Stanley and the General Assembly of Virginia.*

★ ★ ★

For those going to Alaska we can recommend the Hotel Halsingland at Port Chilkoot, "Gateway to the Interior." Rooms range, single, from \$3.50 to \$5.00 and meals—Breakfast \$1.25, Lunch \$1.50 and Dinner \$2.50. Hilma and Clarence Mattson, the proprietors, assure a hearty welcome.

★ ★ ★

*The American Hotel Association reports that during the past year the hotels in the country have spent about \$200,000,000 on such improvements for guest comforts as air conditioning, decoration, pools, children's playgrounds, etc.*

★ ★ ★

The M. V. "Bluenose," between Bar Harbor, Maine and Yarmouth, Nova Scotia, will begin daily round trips on June 26th. The distance overland from Bar Harbor to Yarmouth is more than 700 miles, or about 15 hours driving time in contrast to a delightful leisurely sail of a few hours. The "Bluenose" will carry 500 passengers.

★ ★ ★

*Something new in North Carolina—deluxe golfer's motel is in the planning stage for the Pinehurst—Southern Pines*

*area. This will be a welcome addition to the many hotels and motels now serving this popular golfers' paradise.*

★ ★ ★

A letter from Quincy Sturgis, who wrote us for travel hints and suggestions, which says in part, "We procured a Sinclair Oil Credit Card that we might show our appreciation for their help and used their gas whenever available on the trip. My wife and I also wish to thank The Elks Magazine Travel Service for its fine help in planning our trip."

★ ★ ★

*For those going abroad or beyond the U. S. boundaries a suggestion that steps taken now to meet inoculation requirements can save travel trouble later. A smallpox vaccination within three years is needed to enter many countries and to return to the U. S. Shots for typhoid fever, cholera and yellow fever are advisable—or a "must"—for travel in certain areas. Also some countries demand a statement about your health from your physician. Consult your local travel agent or public-health officer.*

★ ★ ★

*1957 will see the biggest travel show ever in this country at the New York City Coliseum, February 2-10. Displays will feature resort areas in every part of the world and all the latest in travel. This tremendous Travelrama will occupy two floors.*

## In the Doghouse

(Continued from page 28)

side him. Many people have pronounced the statue as the most faithful as well as beautiful portrayal of the young Lincoln that was ever made. The dog is not an accident of art; instead, a deliberate intention to symbolize Lincoln's fondness for dogs and the compassion and understanding he had for all animals. As a youngster he was often accompanied by a hound owned by his father when he would roam the Kentucky hills. As those who have read his biography know, he had few periods of relaxation from his great responsibilities and during those stolen moments it seemed that he most enjoyed playing with the family dog. When the stork visited the White House dog and cat at the same time the Lincoln children showed a lively interest and the Great Man himself was not above spreading the news to the many official callers who visited the White House to discuss the affairs of the nation.

President Grant, while general in the Union Army, often had as a companion a hound that had attached itself to one of his regiments. While a pitiless fighter when the war was in doubt, Grant was endowed with a wide streak of kindness not only for men but for animals. Not many of our Presidents were more given to hunting and fishing than Grover Cleveland. Quite naturally he preferred field

dogs, setters, pointers, spaniels and beagles and his many hunting expeditions were marked by one or more of these varieties of dogs, depending upon the nature of the game.

As an outdoorsman, and one whose fondness for nearly all animals was pronounced, Theodore Roosevelt was perhaps the most active and enthusiastic of all our Chief Executives. Among his animal friends at various times there were lizards, ponies, cats, guinea pigs and, of course, dogs. High in the President's favor was the rat terrier Scamp, a dog that for a long time was an almost constant companion to him. This very likely was the dog which today is known as the Manchester terrier, a dog pretty much the size of a foxterrier, smooth-coated, trim and neat, colored black and tan. He's a perky, alert little fellow and was some years ago better known than he is today, although he's recapturing public interest. Mrs. Roosevelt's favorite was the dog Gem.

When Warren G. Harding was President he owned, or was owned by, the dog Laddie Buck, a half brother to Mr. Wilson's Laddie Boy. For a while President Coolidge endured the shenanigans of the wirehaired terrier Peter Pan but in time Peter came to take his duties so seriously that he fancied himself the sole protector

of the entire White House and its grounds much to the confusion and annoyance of the various workmen and White House guards whose heels he would nip with or without provocation. Eventually Peter was banished in the interests of harmony and peace, being given to a friend of the President who lived where callers and strangers and workmen, too, were not so much a part of the landscape. The special favorite of the President was the sheepdog Rob Roy who became a coffee toper. The staid "Silent Cal", as he was affectionately known to many Americans, occasionally enjoyed startling his guests by pouring a saucer of coffee for Rob Roy during or at the end of a meal. Another White House pet was the white collie often photographed with Mrs. Coolidge. The dog, Prudence Prim, was said to have perfect manners and would often behave as if she were the hostess and not Mrs. Coolidge.

Herbert Hoover had a German shepherd dog King Tut but Tut passed on to that place where we assume that all good dogs go. The dog Pat replaced him. Now Pat was a smart cookie. He'd taught himself to open doors and in this way must have saved the residents of the White House a lot of mileage. But Pat didn't reign alone too long; another dog, a Norwegian elkhound, arrived to share



the honors with him. This didn't interrupt Pat's door-opening routine; he'd simply open the door for himself and the elkhound and so far as I can learn both dogs got along happily.

No dog was more closely identified with a President than the Scottish terrier Fala, dog of Franklin Roosevelt. Fala, kennel name Murray of Fallahill, was a gift to the President from a friend, Miss Katherine B. Davies of Westport, Connecticut. Fala was named for the estate of F. D. R.'s relatives, the Murrays of Fallahill, Scotland. Fala made news and was good copy for the reporters. He could be counted upon to sit at the feet of the President during press conferences and his activities were often the subject of news stories coming from the White House. But Mr. Fala had one bad habit; he would at times mysteriously disappear. He never roamed very far and, of course, was either returned home by some well-wisher or found his own way back.

## Visiting the Lodges

(Continued from page 9)

the Grand Ballroom of the Fontainebleau Hotel with over 500 Elks and their ladies present. All twelve lodges of the Florida South District were represented, and visiting dignitaries included Past Grand Exalted Ruler Sam Stern, members of the Grand Lodge Pension Committee John K. Burch and Hugh W. Hicks, Grand Treasurer Edward A. Spry, member Grand Lodge Activities Committee James Gunn, Past Grand Tiler Irving Unger and Past Chairman of the State Assn. Committee Joseph I. Leonard. The following afternoon Grand Exalted Ruler and Mrs. Walker were guests of the Gulfstream Park Race Track with Past Grand Exalted Ruler George I. Hall and Mrs. Hall accompanying them. Past State Pres. William P. Mooty was host. Tuesday afternoon Mr. Walker stopped briefly at FT. LAUDERDALE LODGE on his way to POMPANO BEACH LODGE. The Grand Exalted Ruler and party were met on the outskirts of Pompano Beach by Exalted Ruler E. H. Haynie and a delegation who escorted them to City Hall, where a key to the city was presented. Over 200 Elks and visitors were present when Mr. Walker dedicated the new home of Pompano Beach Lodge.

Maurice A. Brown, Mayor of Saginaw, Mich., was on hand to welcome Grand Exalted Ruler Walker when he visited Saginaw Lodge on April 25th. Standing at the left of Mayor Brown is Exalted Ruler H. James Neilson.



Nearly everyone in Washington knew him so he had no chance of becoming a chronic tramp. His trancies in time became so frequent that he had to be confined to a wired enclosure. At the third inauguration he tried to horn in on the affair but was taken from the President's car by one of the bodyguards. Fala made the last trip from Warm Springs to the White House and from there to the Roosevelt residence at Hyde Park.

Nearly all of the Presidents have at one time or another received dogs as gifts from well-meaning admirers, which has sometimes been a cause of embarrassment to those recipients who for various reasons found it inconvenient to have a dog in the Presidential Mansion. But all such purps were given good homes elsewhere. Yes, Fido has resided in high places, has been the companion of Presidents and perhaps will continue to be as long as we have a Number One man living at 1600 Pennsylvania Avenue.

On the morning of March 14, Brothers Walker and Wall, accompanied by their wives, ER Newman and Mr. and Mrs. Tony Rothwell, left for PAHOKEE. The party was met mid-way by a motorcade headed by DD L. R. Fraser and Mayor Lewis Friend. That evening approximately 400 Elks and their ladies attended a barbecue, which was followed by a dance. Next morning, March 15, the party was escorted by PER James W. Vann and Mrs. Vann to Stuart, where the new home of STUART-JENSEN LODGE was dedicated by the Grand Exalted Ruler. Exalted Ruler Ward Albertson, his officers and Brother Zack Mosley and their wives entertained at a luncheon.

Leaving Stuart in the early afternoon for Daytona Beach, the party was met by ER Melvin Orfinger, past member of the Grand Lodge State Assn. Committee Cullen H. Talton, DD William Lieberman and several others. On the afternoon of March 16, accompanied by Past Grand Exalted Ruler Robert S. Barrett, Grand Trustee Wall, District Deputy William Lieberman and Grand Lodge Activities Coordinator Bert A. Thomipson, the Grand Exalted Ruler placed a wreath on the mausoleum

# Become an ACCOUNTANT-

Auditor—C. P. A.

The demand for skilled accountants—men who really know their business—is increasing. National and state legislation is requiring of business much more in the way of Auditing, Cost Accounting, Business Law, and Income Tax Procedure. Men who prove their qualifications in this important field are promoted to responsible executive positions.

### SEND FOR FREE BOOK

Knowledge of bookkeeping unnecessary. We train you from ground up, or according to your individual needs. Low cost; easy terms.

Send name and address on the lines below for free illustrated book describing the LaSalle Accounting training and the opportunities in this highly profitable field.

**LASALLE EXTENSION UNIVERSITY**  
A Correspondence Institution

417 S. Dearborn St., Dept. 7328H, Chicago 5, Ill.

Name.....

Address.....

City.....Zone.....State.....

## REAL ESTATE BE A BROKER

PAYS BIG! SEND FOR FREE, BIG, ILLUSTRATED CATALOG NOW! Graduates report making substantial incomes. Start and run your own business quickly. Men, women of all ages learn easily. Course covers Sales, Property Management, Appraising, Loans, Mortgages, and related subjects. **STUDY AT HOME** or in classrooms in leading cities. Diploma awarded. Write TODAY for free book! No obligation.

Approved for World War II and Korean Veterans  
**WEAVER SCHOOL OF REAL ESTATE** (Est. 1936)  
2020H Grand Avenue Kansas City, Mo.

## BOOK MANUSCRIPTS CONSIDERED

by cooperative publisher who offers authors early publication, higher royalty, national distribution, and beautifully designed books. All subjects welcomed. Write, or send your manuscript directly.

**GREENWICH BOOK PUBLISHERS**  
Attn. Mr. Essex 489 Fifth Avenue  
New York 17, N. Y.

## Drive with Confidence

DINSMORE Auto Compasses

Shows you the right way—the short cuts. Saves time, money. Write for new compass history folder. "Pants—Knives—Compasses," and name of nearest dealer.

DINSMORE INSTRUMENT CO., 1812-33 Kelso St., Flint 1, Mich.

## SCHOOL & COLLEGE INFORMATION

All Colleges, Junior Colleges, Preparatory, Military, Boarding and Children's Schools and Camps. Anywhere in U. S. Est. 43 years. Mention age and special needs. Apply now. Visit, write or phone Plaza 7-4440.  
AMERICAN SCHOOLS & COLLEGES ASSOC.  
34th floor RCA Bldg., 30 Rockefeller Plaza, New York, N. Y.

## FOR EASIEST EXTRA MONEY

Sell NEW EXCLUSIVE 25 for \$1.25  
**TALL CHRISTMAS CARDS**

Quickest Way to Make \$75.00

EXCLUSIVE "Gold Luxury" Assortment pays you big 75¢ profit on every \$1.25 box—\$75.00 on 100. Make more with other Christmas EXCLUSIVES—big selection Name-Imprinted Cards; TALL Card, 21 in \$1 box; 4-in-1 "Simply Colossal" Box; Gift WRAPS BY-THE-YARD, 56 ft. roll; sensational new Gift Novelties; over 250 money-makers. You make highest profits plus EXTRA CASH BONUS. Money-back Guarantee assures you up to 20¢ more profit per box. EXTRA SAMPLES AT 10¢, other surprises. Send coupon for Free Trial samples NOW.

**FREE OFFER!**  
POP-UP TOASTER  
Salt & Pepper Set  
for prompt action

**CARDINAL CRAFTSMEN**  
1400 State Ave., Dept. H-61, Cincinnati 14, Ohio  
Please send money-making kit of 5 boxes on approval, FREE Personalized Samples and FREE offers.  
Name.....  
Address.....  
City & State.....



of Past Grand Exalted Ruler David Sholtz, who is interred at Daytona Beach.

That evening **DAYTONA BEACH LODGE** gave a dinner in honor of Mr. Walker, at which time Judge Victor O. Wehle, member of the Grand Lodge State Assn. Committee, acted as Toastmaster. He introduced Dr. Barrett, who presented the Grand Exalted Ruler to over 200 who were in attendance. On the morning of March 17th, Exalted Ruler Ray Buffington and a large delegation from **ORLANDO LODGE** escorted the Grand Exalted Ruler's party to **UMATILLA, FLA.**, where the Harry-Anna Elks Crippled Childrens Home is located. A state-wide gathering of Elk leaders and the Home Committee welcomed Mr. Walker. After a tour of the Home conducted by State Sec. James J. Fernandez a luncheon was served. A caravan of over forty cars then escorted the Grand Exalted Ruler to Orlando Lodge, which that evening gave a banquet in the Grand Exalted Ruler's honor attended by over 300. Sunday morning, March 18, Exalted Ruler Ray Buffington and several members of his committee escorted Mr. and Mrs. Walker to **WINTER HAVEN**, where the party was met by ER Raymond O. Bice, Jr. and his wife. A luncheon at world-famous Cypress Gardens followed. A special water and ski show was presented. The Grand Exalted Ruler then returned to Orlando to dedicate the lodge's new Boy Scout Home.

Monday morning, March 19, Mr. and Mrs. Walker left by plane for New Orleans, stopping briefly at **TAMPA**, where DD George Hickey, ER John Williams and others met them for breakfast.

The Grand Exalted Ruler and his wife were met at the airport in **NEW ORLEANS, LA.**, on the morning of March 19th, after which they called on Past Grand Exalted Ruler Edward Rightor, who is a member of New Orleans Lodge. They were then taken to the lodge for a luncheon at which Exalted Ruler Guy L. Deano, Jr., was host. After a sightseeing trip, the officers of the lodge met with Mr. and Mrs. Walker for a dinner meeting at Antoine's Restaurant.

On March 20th, Mr. and Mrs. Walker arrived by plane at Gulfport, Miss., for a three-day vacation and informal visits to **GULFPORT, BILOXI and PASCAGOULA LODGES**. Mr. Walker made his official visits to these lodges last fall, but was so impressed by the Gulf area that he decided then to return at a later date with Mrs. Walker for a vacation. They were met at Gulfport Lodge by Mayor R. B. Meadows Jr., Exalted Ruler Vincent A. Dauro and Past Exalted Rulers A. W. Lang, Arthur W. Lang Jr., M. G. Hurd, R. H. Hardtner, Earl Buckley and D. M. Graham Jr. All three lodges held informal receptions in honor of Mr. and Mrs. Walker.

**PULASKI, VA., LODGE** was host to the Grand Exalted Ruler on March 23rd and honored him with a reception and dinner at Maple Shade Inn attended by the lodge officers and their wives. Following the regular business meeting of the lodge, a dance was given for the Grand Exalted Ruler and visiting dignitaries included

Past State Presidents Charles D. Fox, Jr. and Walter Barrick and District Deputies Frank G. Payne Jr., Paul S. Johnson and E. E. Gatewood.

On April 1st the Grand Exalted Ruler and his wife arrived in Boston by train and were met at Back Bay Station by Past Grand Exalted Rulers John F. Malley and E. Mark Sullivan, Grand Treasurer Edward A. Spry, member Grand Lodge Judiciary Committee Judge John E. Fenton, member Grand Lodge Ritualistic Committee William F. Hogan, District Deputy Frank J. O'Rourke, Pres. Mass. Elks Assn. Michael J. McNamara, Exalted Ruler Charles M. Zellen and the other officers of **EVERETT, MASS., LODGE**. He was interviewed at the station by three reporters from Boston newspapers and after he arrived at a suite at the Sheraton Plaza Hotel he was interviewed over Station WHIL. The party then enjoyed an informal dinner at the hotel. Early the following evening a police escort took the Grand Exalted Ruler to Everett Lodge for the 55th Anniversary Celebration. At a reception Mr. Walker personally greeted 250 Everett Elks. A banquet followed. In addition to the group that met Mr. Walker at the station in Boston, Lieutenant Governor Sumner Whittier was present at the banquet to extend the greetings of the Commonwealth and Mayor Philip J. Crowley was present to extend the greetings of the city. Past District Deputy William F. Hogan related the history of the lodge and Charter Member James Fitzmaurice, who was Exalted Ruler of Everett Lodge in 1903, was present and spoke briefly.

Host to the Grand Exalted Ruler on April 4th were **WILMINGTON and DOVER, DEL., LODGES**, which gave a joint dinner in his honor at the Hotel Rodney in Wilmington. About 120 members were in attendance. Past Exalted Ruler Alton H. Jacobs was Toastmaster and Past Exalted Ruler Lee J. Buckley introduced Mr. Walker.

A committee of lodge officers and Past

Exalted Rulers met the Grand Exalted Ruler at **WHEELING, W. VA.**, on April 5 and escorted him to Oglebay Park, Wheeling's beautiful City Park. A reception was held at the Park and that evening there was a banquet followed by a meeting at which Mr. Walker installed the new officers. Past Grand Exalted Ruler Wade H. Kepner was honorary chairman of the committee making the arrangements for the Grand Exalted Ruler's visit and Exalted Ruler Morgan Wallace was general chairman.

On April 7th, the Pennsylvania Elks South-west District Assn. held a dinner dance honoring Grand Exalted Ruler Walker in the Grand Ballroom of the William Penn Hotel, **PITTSBURGH**, with more than 1,000 Elks and their ladies in attendance. Grand Secretary Lee A. Donaldson was Chairman of the event and Past State Pres. Wm. D. Hancher was Vice-Chairman. Fred N. Reno, Past District Deputy, was Secretary-Treas. Past Grand Exalted Ruler Howard R. Davis, State Pres. Walter Urben, Vice-Pres. Lewis A. Heisey, Sec. Wm. Gould and Trustee Clarence Thompson were guests of the Association at the dinner. Also present were Past State Presidents Barney Wentz, Earl Pitzer, Ruel H. Smith, Mike Horne, Wilbur Warner, Harry Kleeaan and Francis Benson. Grand Secretary Donaldson was Toastmaster.

The evening of April 8th, the Grand Exalted Ruler arrived at **FREDERICKSBURG, VA., LODGE** and was greeted by a delegation which included Exalted Ruler Stanley B. Smellings, and Past Exalted Rulers William B. F. Cole, Benjamin T. Pitts and Lafayette H. Biscoe. The next day the lodge gave an informal luncheon in honor of the Grand Exalted Ruler at the Princess Anne Hotel, at which time Mr. Walker was introduced to Brother William K. Goolrick, one of the two surviving charter members of the lodge. Following the luncheon the Grand Exalted Ruler was conducted on a tour of historical points. Early that evening there was a reception



Supt. Thomas J. Brady of the Elks National Home is photographed with the sign he has had erected along the four-lane Route 460 to attract visitors to the Home. Mr. Brady, incidentally, was the subject of a highly laudatory article in "The Town Crier" column of the local newspaper recently which called him "Bedford's greatest booster". The article covered a Town Council meeting during which Mayor E. L. Carlyle paid tribute to Mr. Brady, saying in part, "I know of no one who has taken the interest in the town that Mr. Brady has."



at the lodge, followed by a buffet dinner. Two hundred fifty members and guests were present, including several city officials and members from Charlottesville and Richmond Lodges. Past District Deputy Cole was Master of Ceremonies.

Grand Exalted Ruler Walker arrived at FLINT on April 23rd for a three-day tour of Michigan lodges. He was met at the city limits by a welcoming committee consisting of Exalted Ruler Karl M. Smith, Jr., Past Exalted Ruler John M. Byers and Mayor George Algae, who is a member of Flint Lodge. At the lodge, he was greeted by Past District Deputies Albert Lyon and Paul Phillips and over 200 Elks from Flint, Grand Rapids, Saginaw, Lansing, Ionia, Royal Oak, Owosso, Bessemer, Ferndale and Niles Lodges. After meeting the Brothers, Mr. Walker gave an inspiring address which stressed the importance of the Elks National Foundation to the Order and in which he paid particular tribute to late Judge Jay H. Payne, Past Pres. of the Michigan Elks Assn., who passed away only a few days before Mr. Walker arrived in Michigan. At the time of his death Judge Payne was a member of the Grand Lodge Committee on Judiciary.

On April 24th, the Grand Exalted Ruler was at STURGIS LODGE to attend a luncheon. About 90 members and guests greeted him when he arrived at the Lodge. Brother Jack Dunten acted as Master of Ceremonies and introduced Exalted Ruler Bruce Hall. Mayor Leo Yoder then was introduced, as was Past State Pres. S. Glen Converse. District Deputy Dean Wilkinson presented the Grand Exalted Ruler, who particularly commended the Elks of Michigan for the splendid work they are doing in Youth Activity Programs.

En route to Lansing that day, the Grand Exalted Ruler stopped at BATTLE CREEK LODGE for an afternoon reception. He was greeted by Exalted Ruler Nick Gaetano and Brother V. W. Rouse, who was chairman of the arrangement committee for Mr. Walker's reception. The Grand Exalted Ruler was met at the city limits of LANSING by a police escort and a welcoming committee headed by Past Exalted Ruler Carlisle Carver and Exalted Ruler Roland Shook. With Mr. Walker were member Grand Lodge Judiciary Comm. Benjamin F. Watson, Past Pres. S. Glen Converse and District Deputy L. M. Richard. In the evening a banquet and ritualistic ceremony were held, and a class of 41 was initiated in the Grand Exalted Ruler's honor.

The following evening Mr. Walker was at PONTIAC LODGE for a banquet and dedication of the new \$400,000 building addition. This outstanding occasion was attended by a capacity group of over 700.

Accompanying the Grand Exalted Ruler were: member Grand Lodge Pension Committee John K. Burch; member Grand Lodge Ritualistic Committee Charles T. Noble; member Grand Lodge Judiciary Comm. Benjamin F. Watson; Past Grand Tiler Irvine J. Unger; State Pres. Lewis

A. Koepfgen, Vice-Pres. Robert A. Burns, Sec. Leland L. Hamilton and Trustee Edwin P. Breen; Past State Presidents S. Glen Converse and Clement Vogel; District Deputies L. M. Richard, Dean T. Wilkinson and John Cooper. Following the introduction of Grand Lodge and State Association officers, Toastmaster T. P. Gilotte introduced the many state, county and city officials present at the banquet. The Grand Exalted Ruler was welcomed to Michigan by Governor G. Mennen Williams, who is a member of Lansing Lodge. In his address the Grand Exalted Ruler congratulated Pontiac Lodge on its growth to nearly 3,500 members, the largest lodge membership in the state.

TOLEDO, OHIO, LODGE was host to the Grand Exalted Ruler at a reception and banquet on April 26th. Present at the banquet were Past Grand Exalted Ruler Edward J. McCormick, member Grand Forum John C. Cochrane, Past District Deputy Karl P. Rumpf and District Deputy Elwood Reed. Highlight of the occasion was a gathering of members of a Boy Scout troop sponsored by Toledo Lodge. This arrangement was made by Trustee Fred Ehrle, who for thirty years has headed Boy Scout activities sponsored by Toledo Lodge and is chiefly responsible for the construction of the outstanding Boy Scout cabins at the Toledo Boy Scout Reservation, one of the finest in America.

The First Anniversary Celebration of GIRARD, OHIO, LODGE was held from April 20-28, and on April 27th the Grand Exalted Ruler and Mrs. Walker were present to dedicate the lodge's home. They arrived early in the afternoon and were accompanied by Past Grand Exalted Ruler Edward J. McCormick, member Grand Forum John C. Cochrane, Edwin W. Clay, Exalted Ruler of Toledo Lodge, Fred Ehrle and their wives. They were escorted to their motel by a motorcade of Girard officers and their wives, where they were met by former Chairman Board of Grand Trustees Fred L. Bohn. The party was escorted to the Lodge by about 25 Trumbull County Deputy Sheriffs on horseback, after which the dedication ceremonies were held. That evening there was a banquet and Brother Cochrane introduced the Grand Exalted Ruler. Dr. McCormick expressed his pride in the progress made by the Girard Lodge during the year and Fred L. Bohn was introduced to those present. Exalted Ruler Albert H. Stringer was host for this outstanding occasion and also served as General Chairman of the Dedication Program Committee.

With our July issue, we conclude our regular monthly news reports and photographic coverage of Grand Exalted Ruler Walker's visits to subordinate lodges. However, photographs of visits which were not received in time for this issue, or of visits taking place later than our closing date, will be included in the forthcoming subordinate lodge news pages.

## 30% MORE SEATING CAPACITY

American Seating's new folding chair has independent-fold seat, saving nine inches over normal back-to-back spacing. Upholstered spring-arch seat. Body-contour styling. Wide choice of colors and upholstery.



Write Dept. 180-F.

**AMERICAN SEATING**

Grand Rapids 2, Michigan

Branch Offices and Distributors in Principal Cities



### Everlasting Bronze BOOK OF MEMORY

For listing 100 to 3000 names economically. Write for free folders including photos of hand-chased cast bronze plaques.

NEWMAN BROTHERS, Inc.  
Dept. 722, Cincinnati 3, Ohio



### DRAINS cellars, cisterns, wash tubs; IRRIGATES - CIRCULATES - SPRAYS

Type P Pump has 1,001 uses. Up to 3,000 GPH; 450 GPH 80' high; or 1,800 GPH from 25' well. Use 1/8 to 3/4 HP motor. Coupling included free. 1" inlet; 3/4" outlet. Stainless shaft. Won't rust or clog. . . . . \$7.95  
Heavy Duty Ball-Bearing Pump. Up to 7,500 GPH. 1 1/4" inlet; 1" outlet. \$12.95. Postpaid if cash with order. Send for yours today. Money Back Guarantee.

LABAWCO PUMPS, Belle Mead 58B, N. J.



for  
AULD  
LANG  
SYNE

For that worthy member who can point to 25 years of membership in the Elks here is a gift that he's sure to prize highly as a token of the many years he has been an Elk and for the whole-hearted warmth of feeling it expresses. Yes, 25 years IS a long time and well warrants recognition and there's scarcely a better way to show this than by giving that Elk one of these handsome, 10 kt gold, splendidly enameled red, white and blue 25 year membership pins. A Christmas gift unusual. 10 kt gold plated post and attaching button. Please order by number. 25 year pin No. 3—\$8.25. Price includes Federal tax. For N. Y. City sales add 3% tax. Delivery within 2 weeks. Order TODAY from THE ELKS MAGAZINE, 386 Fourth Ave., N. Y. City 16, N. Y.

## FREE FOR ASTHMA

If you suffer with attacks of Asthma and choke and gasp for breath, if restful sleep is difficult because of the struggle to breathe, don't fail to send at once to the Frontier Asthma Company for a FREE trial of the FRONTIER ASTHMA MEDICINE, a preparation for temporary symptomatic relief of paroxysms of Bronchial Asthma. No matter where you live or whether you have faith in any medicine under the sun, send today for this free trial. It will cost you nothing. FRONTIER ASTHMA Co. 496-A FRONTIER BLDG. 462 NIAGARA ST. BUFFALO 1, N. Y.

## STOP Skin Torment

Very first use of soothing, cooling liquid D. D. D. Prescription positively relieves raw red itch—caused by eczema, rashes, scalp irritation, chafing—other itch troubles. Greaseless, stainless. 43¢ trial bottle must satisfy or money back. Ask your druggist for D. D. D. PRESCRIPTION.



# ELKS



# WORKSHOP

How to build a play coaster for the children.

BY HARRY WALTON

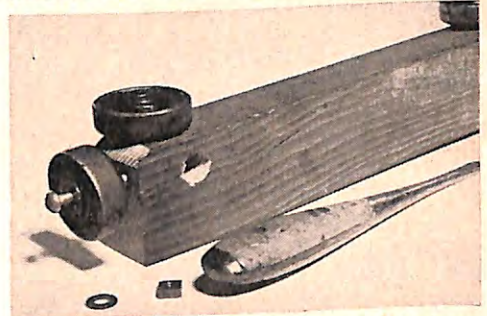

Drawbolts are used to fasten skate wheels on wood axles. Cross hole is for nut and washer.

**A** REAL LITTLE ROLLER COASTER will guarantee youngsters plenty of active outdoor fun. Girls as well as boys enjoy this unusual piece of playground equipment. It is simple to build, and the cost of parts is low.

Instead of costly flanged wheels, those from a pair of ball-bearing roller skates (or skate replacement wheels at 25 or 30 cents apiece) are used. The track is ordinary furring strip, commonly sold for about three cents a foot. Ties are two-by-two stock at about six cents a foot.

New lumber for a fifty-foot stretch of track will come to about six dollars. If used wood is available, this cost can be cut by half.

**LOCATING THE COASTER.** For three to six-year-olds, a straight run of twenty feet with just enough slope to keep the car rolling may be ample. Older children will prefer a longer run, brisker speed, and a few curves to liven things up. As surveyor and construction engineer, you can lay the line to suit.

Even gently sloping ground will give a good run, for the ball-bearing wheels spin very freely. If the ground is level, you can provide the necessary pitch by

building a starting platform. A steep slope will give a thrilling ride, but requires a long level stretch beyond it, or even a slight rise, to slow the car down safely at the end of the track.

**FOUR WHEELS GUIDE IT.** The car rolls on four wheels on top of the track. Four other wheels are mounted flat to run against the insides of the rails. These keep the car on the track.

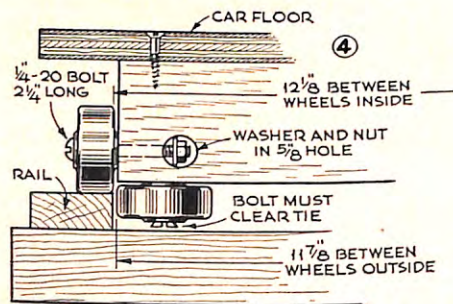

A piece of  $\frac{1}{2}$ " or  $\frac{5}{8}$ " plywood is fine for the floor of the little car. Lacking this, you can build up the floor from three 6" wide boards. The wooden axles will serve as cleats to fasten them together.

It is important to cut the axles exactly  $11\frac{7}{8}$ " long and with square ends. Make them of two-by-three stock (which actually measures about  $1\frac{5}{8}$ " by  $2\frac{5}{8}$ ").

On a smooth table or bench, lay an axle flat (wide face down) on top of a  $\frac{1}{2}$ " thick piece of wood or similar stock. Hold a skate wheel on the workbench against the narrow face of the axle and flush with the end as in Figure 1. Mark the wood at the center of the wheel by putting a  $\frac{1}{4}$ " bolt in the hole in the wheel and hitting the bolt with a hammer.

Mark the other end the same way. Then turn the axle on edge with the marked face down and a  $\frac{1}{4}$ " thickness under it. Hold a wheel against the end,  $\frac{1}{8}$ " in from the face that was down, when the other wheels were marked (Figure 2). Spot the wheel center with a bolt as before.

These measurements are for standard skate wheels  $1\frac{7}{8}$ " in diameter. For others, alter dimensions to suit. The important thing is to space the horizontal wheels (those parallel to one edge)  $11\frac{7}{8}$ " apart on the outside, and to stagger the bolt holes so that the bolts will not conflict.

Drill these bolt holes with a  $\frac{1}{4}$ " drill to a depth of  $1\frac{1}{4}$ ". Then use a try square to mark across on the centerline of each

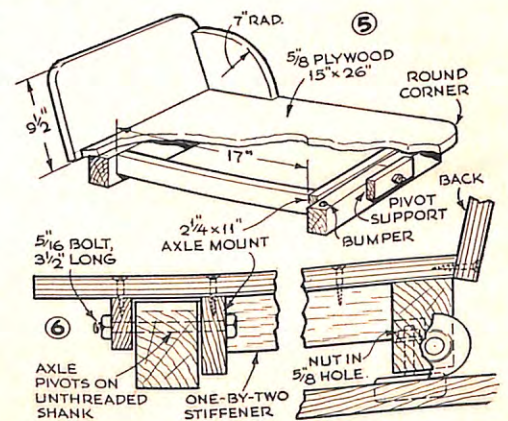

hole to the nearer adjacent face. Bore a  $\frac{5}{8}$ " or  $\frac{3}{4}$ " hole  $1\frac{1}{4}$ " from the axle end in one case, and  $1\frac{1}{4}$ " up from the bottom edge in the other, as in Figure 3, about  $\frac{7}{8}$ " deep.

Use flat-head  $\frac{1}{4}$ "-20 bolts to mount the horizontal wheels so that the bolt heads will clear the ties (Figure 4).

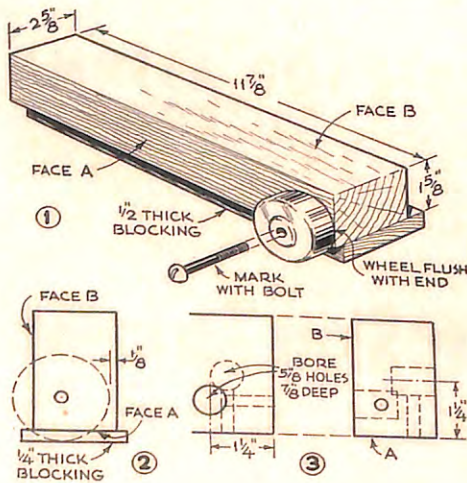



Roundhead bolts are better for the other four wheels. Tighten the skate wheels directly against the wooden axle surfaces, without washers. They should spin freely when mounted this way.

**FINISHING THE CAR.** If you plan only straight track, both axles can be screwed directly to the car floor, the rear one at the back edge, the front one 17"

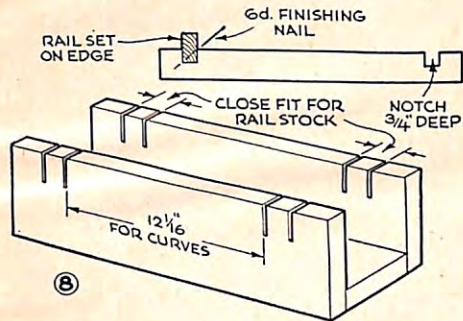
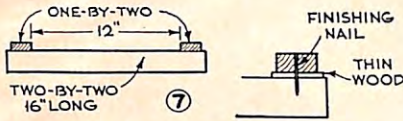

forward (Figure 5). On curved or uneven track, the car will hug the rails better if the front axle is pivoted as shown in Figures 5 and 6.

For this, screw two pieces of  $\frac{3}{4}$ " stock to the floor as shown so that the axle can fit freely between them. Drill through for a  $\frac{5}{16}$ " bolt. Cut a thin wedge off the top of the axle at both ends so that it can rock no more than  $\frac{1}{4}$ ". Should you cut away too much, drive rubber-headed tacks in where they will limit the tilt to  $\frac{1}{8}$ " on each side. Too much axle play may let the rear flange wheels rise out of the track if the front corners of the car are pushed down.

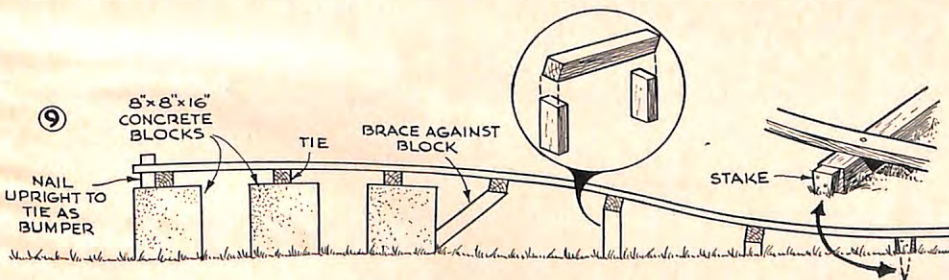

Cut two stiffeners 17" long to fit tightly between the axles, and screw them to the car floor. Bevel the back edge of the floor, add a plywood back and two sides as in Figure 5, and paint the car.

**LAY TRACKS TWO WAYS.** For straight runs, nail furring strips flat to the ties exactly 12" apart as in Figure 7. A piece of two-by-four, cut square to that length, makes a handy track gauge for spacing the second rail on each tie. Use a tie every twelve to fifteen inches. If the flange wheels should fail to clear the ties, raise the track slightly by inserting bits of wood shingle under it (Figure 7).

Furring strip will not readily bend in the flat plane, so turn it on edge as in Figure 8 to make curved track. If you

have a power saw, you can notch the ties by mounting a dado head on the arbor. To use a handsaw, make a box jig as shown in Figure 8. Clamp each tie in, cut all four kerfs, and chisel out between the saw cuts. If you prefer not to notch the ties, nail blocks to the ties outside the rails.

Fasten one rail to its ties. Then brace it against a wall and have a helper hold it in the desired curve (or use stakes or weights to hold it) while you bend and set in the second rail. In notched ties, track will hold its curve even before it is nailed.

Toenail the rails into the tie notches, using 6 d. galvanized finishing nails as in Figure 8. Ties will last longer if dipped in a bucket of creosote beforehand.

**LAYING THE TRACK.** Where a modest starting elevation is called for, two or three concrete blocks can be used as in Figure 9. Fasten ties to them with masonry nails. Lay the rails flat so that they can be bent at the top and bottom of the slope as shown. If the track tends to rise off the ground at the lower end, drive stakes at the ends of the ties and nail the ties to the stakes.

Remove sticks, stones and stubble from under each tie to give it a firm footing. Set ties level except on curves, which may be banked by putting pieces of shingle under the ties or by removing a little soil at one end.

**JOINING TRACK SECTIONS.** To join upright rails, nail both to a common tie. Then bridge the joint with a short piece as in Figure 10, using nails or bolts and nuts. Flat-laid rails need no bridging, but it is well to use a wide tie.

To join a flat rail to an upright one, use a double tie as in Figure 11. Set the

upright rail in notches or nail it against blocks. Nail the second tie to the other at a height that brings the two rails flush on top.

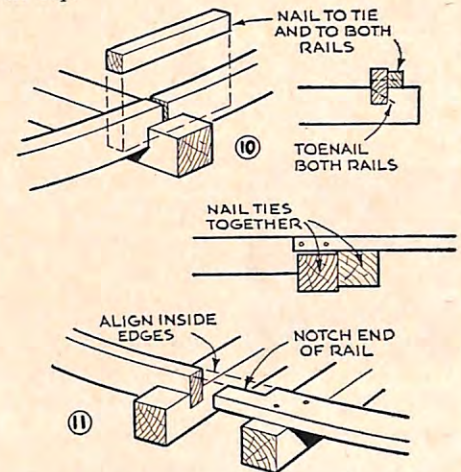

**BRAKING THE CAR.** For safety, and to keep the car from running onto the ground (which would soon damage the ball bearings) it should be brought to a gentle stop. A sufficiently long level stretch will eventually do this. If space is lacking, you can block up the track to provide an upward slope at the end of the run.

Be sure to make several trial runs with ballast on the car before letting the children try it. You may discover it rolls farther or faster than expected. Once sure it is safe, stand aside and watch the kids take over.



Build up short leg with *New Plastic Wood*. Makes a permanent fix—won't chip, crack or peel. *New Improved Plastic Wood* has a finer grain—minimum shrinkage. Takes stain.



**NEW "PLASTIC WOOD"**  
Handles like putty—  
hardens into wood.

## HOW TO START YOUR OWN HOME BUSINESS

and make up to **\$8<sup>80</sup>** an hour—It's Easy  
With What I Call "MY LITTLE MONEY MAKER"



Pay **54¢** for Material  
SELL FOR **\$6.00**

Set it up anywhere—kitchen, basement, attic or garage. Turn out a product that sells for **\$6.00**. Materials cost you only **54c** so you make **\$5.46** profit on every job.

**NO EXPERIENCE NEEDED**  
**No Canvassing or Selling**

Both men and women can easily operate these little Electroplating Machines and make extra money whenever they want it. Here's why. While working or while sleeping—your "Little Money Maker" is busy bronzing baby shoes—coating them with copper to preserve the shoes forever. There

is a tremendous demand for Bronzed Baby Shoes and there are seven ways to get orders without making any house-to-house calls. Lots of orders come to you by mail with the money in the envelopes. Let me send you all the facts about this fascinating home business. I'll show you how you can make up to **\$8.80** an hour from the very beginning. Send your name on a post-card. I'll answer by return mail and the information I send you will not cost you a penny. No salesman will call. Get in touch with me at once so I can help you get started making lots of money.

**Ulmer A. Mason, 1512 Jarvis Ave., Chicago 26, Illinois.**



# Editorial

## GRAND EXALTED RULER JOHN L. WALKER'S YEAR IN OFFICE



In John L. Walker, the Order has had a leader with a comprehensive program, a definite plan to obtain results and a method of measuring them. They all were set forth concisely and clearly in his "Plan For Elkdom's Progress". The soundness of this blue-

print for progress can be measured by the enthusiasm with which it was accepted by the Lodges and individual Elks, and the energy with which they put it into effect.

At the outset of his term as Grand Exalted Ruler, Brother Walker made it clear that "membership control" was the major part of his Plan. The number of members initiated annually averages about 80,000. The number dropped for non-payment of dues averages about 40,000. With an annual loss of about 15,000 through death, the net gain in membership has dropped in recent years to an average of about 25,000.

Impressed by these facts, the Grand Exalted Ruler declared: "It is unhealthy to lose one member for each two we take in". His "membership control" program was aimed directly at this unhealthy situation. To obtain the stimulating effect of competition in his campaign, the Grand Exalted Ruler established two contests. One offered lodge, district, state and national awards for retaining members on the rolls. The other offered awards to lodges.

Regardless of the statistical results of this campaign, its most important contribution has been the focusing of attention on a very serious problem, the creation of a more general awareness of it and, inevitably, a broader and more effective attack upon it.

Grand Exalted Ruler Walker's leadership produced remarkable gains in another important field. His campaign for the Elks National Foundation resulted not only in a record total of contributions to our great benevolent agency, but also in a tremendous increase in the number of individual contributors. He has done much to make giving to the Foundation an annual habit among Elks.

Notwithstanding his generous response to invitations to visit in all parts of the country, Brother Walker has found the time and the energy to give continuous and effective direction to his District Deputies. He has given inspired leadership to his corps of Grand Lodge Officers and Committeemen and has ably and tirelessly supported the work of the Elks National Service Commission.

Brother Walker's charming personality, patience, comradeship and his intense devotion to the Order won him the respect and admiration of all who came in contact with him. A "good fellow" in the best tradition of Elkdom, he was "Johnnie Walker" to all.

Elkdom is indebted to the Old Dominion for giving us Johnnie Walker, and his gracious and charming wife, Kitty. Together, they symbolize the family relationship that is the essence of our Order.

## A LAMB—OR STILL A BEAR?



When the Russian Communist Government decided to substitute group leadership for personal leadership, to discard Stalin's policy of conquest by military force and murder and in place thereof institute a program of conquest by gifts and smiles, only a

few in this country recognized this move as indicating a failure of the conquest-by-arms policy.

More and more people are interpreting this change of policy as recognition of the greater efficiency of the Marshall Plan and other foreign aid plans of similar character that this country has been carrying on and have come to realize that the Russian Government has decided that they can make more progress in communizing the world by the adoption of our methods of making friends.

Our people are beginning to realize, however, that such world conquest is just as much their desire and purpose today as it was in Stalin's day.

Let us not overlook the fact that the new method, allaying the natural distrust and suspicion engendered by the now abandoned policy of conquest by arms, has the possible result of blinding us to the dangers of their tactics. Let us not for one moment doubt that these tactics of infiltration and subversion will continue.

Let us realize that instead of it being discontinued, or even lessened, under the new policy, they will, if we allow ourselves to be off guard, take advantage to pursue those policies even more vigorously and more effectively.

That they intend to hold their military strength and to use it if they do not hoodwink the free people of the world by their program of pretended "sweetness and light" is indicated by the fact that this Russian bear, attempting to make a show of changing into a lamb, naturally enough, permitted the teeth of the bear to break through the sweet smiles of the lamb as did Khrushchev when, in England, he reminded Prime Minister Eden of Russia's possession of the hydrogen bomb, formidable ballistic missiles and a plane that can fly to England in three and a half hours.

Strong evidence that the present program is only intended to allay the suspicions of the people of the capitalistic countries until the time to strike by force has come is found in the report of Secretary Khrushchev to the 20th Congress of the Communist Party. There he said:

"We recognize the need for the revolutionary transformation of capitalist society into socialist society. It is this that distinguishes the revolutionary Marxists from the reformists, the opportunists.

"There is no doubt that in a number of capitalist countries the violent overthrow of the dictatorship of the bourgeoisie and the sharp aggravation of class struggle connected with this are inevitable.

"It is not true that we regard violence and civil war as the only way to remake society, but the use or the non-use of violence in the transition to socialism depends on the resistance of the exploiters.

"In the countries where capitalism is still strong the transition to socialism will be attended by a sharp class revolutionary struggle."

The bear appears to be having some difficulty in playing the part of a lamb.





# You can have a Big Money "shoe store" business **FREE!**

The New **MASON** Plan Shows You How To Make the **EXTRA CASH** You Need!

Here's your big chance to run a highly profitable full-time or spare-time business! You don't invest a cent, and it's *easy* to make the *extra money* you need for that new car . . . house . . . clothes . . . other purchases for yourself and your family. The exciting new Mason Plan works like magic! We rush you a powerful Starting Sales Outfit **FREE**. It includes everything you need to become the Mason Shoe Counselor in your community and start making money the very first hour. Start by selling to friends, relatives, neighbors, people where you work. Soon you'll have a *big-money*, **REPEAT-ORDER** shoe business—because **EVERYBODY** wears shoes, and you'll be amazed how people go for famous Mason Velvet-eez shoes. It's no wonder! These fine shoes are advertised in National magazines and on Television Coast-to-Coast—they bear the famed Good Housekeeping Guarantee Seal—and their special comfort features are acclaimed by people everywhere. Some top-notch men have made as many as 20 sales the very first day!—up to \$10 in an hour, plus large bonus checks!

## You Make Money Right Away With Fast-Selling Items!

No wonder Mason shoes are so easy to sell! There are over 160 different styles for men and women, including smart dress shoes, sporty casuals, and the most practical work shoes ever designed. Notice these *special features*: Velvet-eez Air Cushioned Innersoles that let you walk on air all day long! . . . sturdy Steel Shanks . . . Air cushioned Longitudinal Support . . . work shoes with DuPont Neoprene oil-resistant soles, heels . . . steel toe Safety Shoes . . . high grade leathers.

There is a big market right in your own community for service shoes: gas station and garage men, factory workers, other working men who will stuff your pockets with dollars. These fine shoes are not available in stores . . . people must buy from YOU—and keep buying from you! Here's another big reason people like to buy shoes the Mason way: Because you draw from our huge stock of over 200,000 pairs, you actually "carry" more shoes than the largest store in town! No need to substitute . . . your customers get the style they choose in the exact size and width they order. Perhaps you have seen Mason Air Cushioned shoes advertised on television from Coast to Coast . . . they bear the Good Housekeeping Seal . . . a ready market is awaiting you for this top product.

## We Start You **FREE** . . . Cash In **NOW!**

To get started right away to exciting cash profits, send coupon below. We will rush your Starting Sales Outfit **FREE** . . . featuring 160 fine shoes, fast-selling jackets, and including Air Cushion Demonstrator and everything you need to make money the first hour! The Professional Sales Outfit above with actual samples will be sent to men who qualify. So start cashing in **NOW**—send this valuable coupon **TODAY!**

## DO YOU want this kind of extra money?

Here is actual *proof* of the money-making possibilities in your Mason business! These are taken from hundreds of signed testimonials on file at our factory. Most of these successful men have had no previous selling experience . . . yet all have made handsome *extra* incomes for themselves . . . without investing a single cent! Wouldn't YOU like to make these kind of cash profits?



### Earns \$93.55 in 4 hours!

"On June 5th, I sold 38 pairs of shoes from 6:30 p.m. to 10:30 p.m., earning myself \$93.55 in commissions." J. Kelly, New York. (While this is exceptional, it shows what an ambitious man can do.)



### Earnings Financed Vacation!

"I've used my profits to pay off the final notes on a farm I own and finance a two-weeks vacation in North Carolina for my family." T. Worley, Michigan.



### Averages \$80 extra a week!

"I have made more money since I started this business than in all my past life. My average earnings have been over \$80 a week." C. Tuttle, California.



### Adds Greatly To Pension!

"I know there must be many men like myself who would like to add to their pensions to gain the extra things of life. One forenoon I made a net profit of \$21.75!" C. Mason, Michigan.

If YOU want to start making extra money fill out and mail the coupon TODAY. We will rush your Free Sales Outfit so you can start making a handsome *extra* income right away!

**MASON SHOE MFG. CO.**  
Dept. 402  
CHIPPEWA FALLS, WIS.

## SEND FOR FREE OUTFIT!

Mr. Ned Mason, Dept. 402  
Mason Shoe Mfg. Co.  
Chippewa Falls, Wisconsin

You bet I want to have a BIG MONEY "shoe store" business FREE! Please rush my Starting Sales Outfit that contains everything I need to follow the exciting Mason Plan and start making real money the first hour!

Name \_\_\_\_\_

Address \_\_\_\_\_

Town \_\_\_\_\_ State \_\_\_\_\_



# PACKS MORE PLEASURE

*because it's More  
Perfectly Packed!*



*Satisfy Yourself* with a Milder, Better-Tasting smoke—  
packed for more pleasure by exclusive *Accu-Ray*

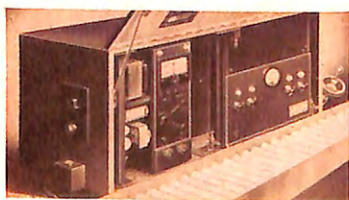

The more perfectly packed your cigarette, the more pleasure it gives... and Accu-Ray packs Chesterfield far more perfectly.



To the touch... to the taste, an Accu-Ray Chesterfield satisfies the most... burns more evenly, smokes much smoother.



Firm and pleasing to the lips... mild yet deeply satisfying to the taste — Chesterfield alone is pleasure-packed by Accu-Ray.



KING SIZE & REGULAR

# CHESTERFIELD MILD, YET *THEY Satisfy!*

© LIGGETT & MYERS TOBACCO CO.