

THE  
**Elks**  
MAGAZINE

In this issue: MAY 1957 W  
STANLEY FRANK • CHARLES YERKOW  
TOM SILER • WILLIAM BYRON MOWERY



Woodi

# NEW, AMAZING, HEAVY-DUTY TRANS-KLEER MATS & RUNNERS!

Buy in ROLL Like Wholesaler!  
Cut to Any Size  
Desired!

**THICK .24  
GAUGE POLY!**  
Tough as  
**RUBBER!**



**17¢**  
SQ. FT. IN 12 FT. ROLL



Protect rugs, carpets, floors from rain, dirt, mud-stained shoes. Place amazing, practical Trans-Kleer at your door during bad weather. When skies are sunny, merely roll up and store away! Trans-Kleer is skid-proof, waterproof, dirt resistant—and semi-transparent so you still see the beauty of your rugs! Already in thousands of American homes. Praised by folks everywhere! Mail coupon now!

12 foot roll (30 square feet in all) costs only \$4.98 — LESS THAN 17¢ PER SQUARE FOOT! An amazing bargain!

## 101 USES In Home, Store, Factory,

- WATERPROOF! • SKIDPROOF! • GREASE & STAIN RESISTANT!
- WASHABLE! • LAYS FLAT! • 5-YEAR WRITTEN GUARANTEE!

Sensational new idea for home and industry. Brand-new, all purpose Trans-Kleer Mats and Runners—scientific new discovery unlike anything you've ever seen or used! You buy Trans-Kleer in a ROLL like a wholesaler—and cut with shears to any size or shape desired. Has 101 uses: Place over rugs near your front door, shop or office to protect costly carpeting on rainy, muddy days. Use as Door Mats, Bath Mats, Shower Mats, Sink Drainboard, Foyer Runners, Stair Treads and Risers, Shelf Protectors, Back-of-Stove Wall Protectors, Car Mats, Flooring in Station Wagons, etc., etc.

Trans-Kleer has advantages of sturdy, thick rubber—at a fraction of the cost! It's Waterproof! Slip-proof! Skidproof! Acid, grease, stain

and dirt resistant! Washable! Dries in minutes! Wipes clean with damp cloth! Lays flat! Constructed of first-quality, heavy-duty THICK .24-gauge semi-transparent polyethylene with 96 strong-gripping, non-skid ribs per foot! 240 RIBS EVERY 2 1/2 FEET! Trans-Kleer is so durable, so long-lasting, so rugged that we give you a 5-Year Replacement Guarantee IN WRITING!

### ENJOY TREMENDOUS CASH SAVINGS!

Here are a few typical cash savings when you use Trans-Kleer heavy-gauge wonder plastic instead of costly rubber, wool, carpet, etc.

- Others pay \$4.98 for a door mat. A 3-foot roll of Trans-Kleer costs only \$1.49. YOU SAVE \$3.49!
- Others pay \$20.00 for 15-feet of stair treads and risers. 18-foot roll of Trans-Kleer costs only \$7.50 —YOU SAVE \$12.50 and you have 3 feet left to use as a spare mat!
- Others pay \$25.00 for carpet runners. A 12-foot roll of Trans-Kleer costs only \$4.98. YOU SAVE \$20.02!

### 5 TIMES ADVERTISED—5 TIMES A SELL-OUT!

We've advertised our Trans-Kleer Mats and Runners 5 times—and 5 times we sold out entire stock. All our customers can't be wrong! Trans-Kleer MUST be good! Once you SEE and USE it you'll agree too! YOUR MONEY BACK promptly if you're not completely satisfied. Hurry. New shipment from factory will go fast. Mail coupon NOW! Guaranteed fast delivery! ALL ROLLS ARE 2 1/2 FEET WIDE: 3 ft.—\$1.49; 6 ft.—\$2.79; 12 ft.—\$4.98; 18 ft.—\$7.50; 24 ft.—\$9.95; 50 ft.—\$17.95; 100 ft.—\$32.95.

**NOTE: Avoid thin, inferior imitations. Trans-Kleer is THICK .24-gauge miracle polyethylene with 240 strong-gripping, non-skid RIBS!**  
MRS. LAVALLE, Inc., Dept. 103-E-136  
585 Water Street, New York 2, N. Y.



**SAVE \$35.00**  
Use on stairs and as runners at fraction of cost of rubber!

**SAVE \$2.50!** Use heavy-gauge Trans-Kleer as drainboard mat or sink tray!

Trans-Kleer protects floors from shoe scuffs! It's skid-proof; children play safely!

Use in laundry room. Trans-Kleer is water-proof, skid-proof!

### Fast Delivery! Mail Coupon! MONEY BACK GUARANTEE!

MRS. LAVALLE, Inc., Dept. 103-E-136  
585 Water Street, New York 2, N. Y.

RUSH amazing new Trans-Kleer Mat & Runner Rolls as checked below. My money refunded promptly if not satisfied. Include 5-Year Replacement Guarantee IN WRITING!

Check, cash, money order enclosed. Send prepaid.  Send COD, plus postal fees.

ALL ROLLS 2 1/2 FEET WIDE!

- 3 ft. 1.49
- 6 ft. 2.79
- 12 ft. 4.98
- 18 ft. 7.50
- 24 ft. 9.95
- 50 ft. 17.95
- 100 ft. 32.95

Name \_\_\_\_\_

Address \_\_\_\_\_

City & State \_\_\_\_\_

Zone \_\_\_\_\_

Canadians: Address 439 King St., W., Toronto



# Tom Wrigley Writes from WASHINGTON

the surroundings. The White House itself would be entirely a residence for the Presidential family, with the exception of the offices of the social secretary and the White House police.

## ASK \$150,000 AWARD

A bill before the Senate, introduced by Senator Saltonstall of Mass., would give retired Captain of the Navy Laurance F. Safford \$150,000 for inventing 20 cryptographic systems. Captain Safford retired at 63 in 1953, after 37 years of service. His marvelous codes, used in World War II, were never deciphered by the enemy. Last year, Congress awarded \$100,000 to Colonel William Friedman of the U. S. Army, who made similar codes.

## SOLAR HOT SPOT

Made from an old Army searchlight, the National Bureau of Standards has perfected a solar furnace capable of producing 6,300 degrees of heat, or two thirds of the surface heat of the sun itself. It's a gigantic "burning glass" in which sunlight is reflected from the huge searchlight mirrors onto a spot about a quarter of an inch in diameter. The furnace is used to test heat resistance of ceramics and other materials.

## SAND FOR SENATORS

One of the many duties performed by Senate pages is to fill the tiny bottles of blotting sand which are on each Senator's desk. The sand is seldom used but it is kept fresh and clean, just in case a Senator might be using a quill pen and a lot of ink. Senators fill their own silver snuff boxes.

## REMOVE SECRECY LABEL

Weather data for Air Force flyers is no longer a Defense Dept. "secret." It is an automatic 55-second telephone recording, changed every hour, giving visibility, ceiling, temperature, wind, etc., and ending with the words "this information is for military use only and dissemination to the public is not authorized." Anyone, however, could look in the Pentagon phone book, where the weather number is listed, and get the information. When a Congressional House Committee called attention to this, red-faced Pentagon top brass removed the "secrecy" label. The weather phone number is Pentagon, ext. 79355.

## BIG CHIEF

In the new African state of Ghana, Frank Holeman, a Washington newspaperman, is known as the "big chief" of the United States. Holeman is big, 6 feet 7, and he was a commanding figure in Ghana with the corps of newsmen covering the recent visit of Vice President Nixon. At the Independence Day ceremonies, the tall reporter wore a sports shirt so splashy in colors it

made the brilliant robes of the Ghana chiefs look drab in comparison. One Ghana notable asked if Holeman, sporting such a wonderful shirt, was the big chief of the Americans. A newsman with the party nodded and replied that Holeman was "chief" of the National Press Club in Washington. That did it. Everybody walked around salaaming. As a matter of fact, Holeman just recently finished his term as president of the Press Club.

## RESERVISTS WELL TREATED

Young men in the new Army Reserve six months' training at Fort Knox, Kentucky, get kid glove treatment, compared to regular army recruits. They are two or three years younger and many are away from home for the first time. They have better quarters, sleep on air mattresses in pup tents and have a lot of off-duty time to fix their autos and work in the hobby shop. Their barracks have curtained windows, individual lockers and tiled showers. They have lots of visitors. Regular army recruits, however, have one advantage—beer in the PX—which is strictly forbidden the reservists. "Mothers wouldn't like it," an officer explained.

## POTOMAC POSIES

Caribbean cruises are not sailing from Washington this Spring, the Potomac River is too shallow in spots . . . The last Air Force B-17 "Flying Fortress" of World War II days has been junked and is now a target for anti-aircraft practice . . . Young graduate engineers and scientists get starting salaries of \$4,480 in Federal jobs but beginners' pay of \$4,700 is recommended . . . For civil defense use, some states are getting property for free which cost the government \$2 million . . . No, the hip boots for his chauffeur on the Senate expense account of Majority Leader Lyndon Johnson of Texas were not for trout fishing. They are used for washing the limousine . . . A Senate Internal Security Subcommittee recommends that representatives of Tass, the Soviet news agency, be barred from all confidential press conferences and denied police press passes . . . Treasury is sending a letter to all parents having babies this year to buy U. S. Savings Bonds for the kids . . . Police seized a good whisky still in operation only a few blocks from the Capitol . . . About 2 million workers were injured while on the job last year, Labor Dept. reports . . . Federal Trade Commission is policing radio and TV ads with monitors, following complaints that what they say or show isn't necessarily so . . . The new A-powered aircraft carrier will cost \$300 million . . . A girl from Indianapolis, making out an application for a government job, filled in the line "Veterans' Preference" with one word, "Sailors."



**S**OMETHING is going to be done about providing more space for the White House offices. Now in the recommended stage, the project will cost up to \$25 million for an executive office building to be constructed on the site of the old State, War and Navy building, just west of the White House. Also planned is a \$2-million rebuilding of the White House West Wing, now used for the Presidential offices. It will be made over into a residence for distinguished visitors. Alterations to the White House East Wing will cost \$150,000 and a tunnel from the White House to the Executive office building will cost \$300,000. It will take four years to do all this and the President has approved the change, although he will be out of office then. The White House offices have been cluttered up for years, way back to F. D. R.'s second term, when the first polio March of Dimes letters had the White House post office clogged for days. President Truman tried to get action but nothing was done. Since then the White House staff has grown from 12 secretaries and administrative assistants to 38. Total employes have increased from 140 to over 300. The plan now discussed is to tear down the old State, War and Navy eye-sore, an architectural monstrosity, shove the White House grounds out to 17th Street on the West and build a three or four-story office building in keeping with

Ships have  
changed since 1830...

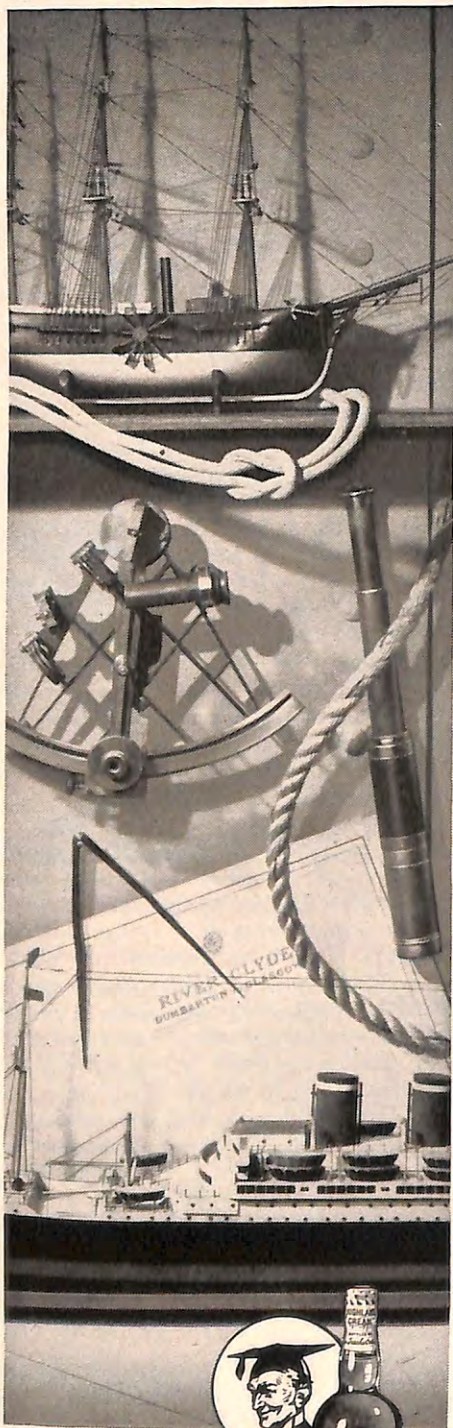

but the good taste  
of **TEACHER'S**  
never changes!



**TEACHER'S**  
HIGHLAND CREAM

86 PROOF • Blended Scotch Whisky  
Schieffelin & Co., New York

# THE Elks MAGAZINE

VOL. 35

MAGAZINE

No. 12

NATIONAL PUBLICATION OF THE BENEVOLENT AND PROTECTIVE ORDER OF ELKS  
OF THE UNITED STATES OF AMERICA, PUBLISHED UNDER THE DIRECTION OF THE  
GRAND LODGE BY THE NATIONAL MEMORIAL AND PUBLICATION COMMISSION.

THE ELKS NATIONAL MEMORIAL AND PUBLICATION COMMISSION

JOHN S. McCLELLAND  
Chairman

EMMETT T. ANDERSON  
Vice-Chairman

JAMES T. HALLINAN  
Treasurer

WADE H. KEPNER  
Secretary

EARL E. JAMES  
Asst. Secy. and Asst. Treas.

JAMES R. NICHOLSON  
General Manager

LEE C. HICKEY  
Editor

REGINA M. FISHER  
Associate Editor

JOSEPH C. JONES  
Art Editor

GENEVIEVE G. CONOVER  
Advertising Production

W. H. MAGRATH  
Controller

JOHN SCHMITT  
Circulation Manager

EDWARD FAUST  
Promotion Manager

EDITORIAL OFFICES, 386 Fourth Avenue, New York 16, N. Y.

## CONTENTS FOR MAY, 1957

COVER BY WOODI ISHMAEL

TOM WRIGLEY WRITES FROM WASHINGTON.....	1
\$28,006 REWARD.....	Stanley Frank 4
DANGER STRUCK.....	Charles Yerkow 6
YOUNG TIGERS IN A HURRY.....	Tom Siler 8
THE HEEDLESS HORSEMEN.....	William Byron Mowery 10
A MESSAGE FROM THE GRAND EXALTED RULER.....	12
REMEMBRANCE STRIKES THE MATCH IN KOREA Through Your National Service Commission.....	13
FOR ELKS WHO TRAVEL.....	Horace Sutton 14
WELCOME TO THE CONVENTION IN SAN FRANCISCO.....	16
ROD AND GUN.....	Ted Trueblood 17
NEWS OF THE LODGES.....	18
ELKS FAMILY SHOPPER.....	22
IN THE DOGHOUSE.....	Ed Faust 33
TRAVELGUIDE.....	34
FREEDOM'S FACTS.....	52
ELKS WORKSHOP.....	Harry Walton 54
EDITORIAL.....	56

ADVERTISING OFFICES

CHICAGO 1  
360 North Michigan Avenue  
STATE 2-6662

NEW YORK 16  
386 Fourth Avenue  
MURRAY HILL 4-5495

LOS ANGELES 17  
1709 West 8th Street  
DUNKIRK 8-8111

SAN FRANCISCO 4  
927 Mills Building  
EXBROOK 2-4073

PORTLAND 4, ORE.  
217 Times Building  
CAPITOL 7-3718

CHANGE OF ADDRESS: POSTMASTER—Please mail Form 3579 notices to: THE ELKS MAGAZINE  
386 Fourth Avenue, New York 16, N. Y.

Members are asked, in changing address, to send this information (1) Name; (2) Lodge number; (3) Membership number; (4) New address; (5) Old address. Please allow 30 days for a change of address to be effected.  
THE ELKS MAGAZINE, Volume 35, No. 12, May, 1957. Published monthly at McCall Street, Dayton, Ohio by the Benevolent and Protective Order of Elks of the United States of America. Entered as second class matter November 2, 1940, at the Post Office at Dayton, Ohio, under the Act of August 24, 1912. Acceptance for mailing at special rate of postage provided for in Section 1103, Act of October 3, 1917, authorized May 20, 1952. Printed in Dayton, Ohio, U.S.A. Single copy price, 20 cents. Subscription price in the United States and its Possessions, for Elks \$1.00 a year; for non-Elks, \$2.00 a year; for Canadian postage, add 50 cents a year; for foreign postage, add \$1.00 a year. Subscriptions are payable in advance. Manuscripts must be typewritten and accompanied by sufficient postage for their return via first class mail. They will be handled with care but this Magazine assumes no responsibility for their safety.  
Copyright, 1957, by the Benevolent and Protective Order of Elks of the United States of America

# ELKS NATIONAL FOUNDATION



## "The Joy of Giving"

Dennis James was Master of Ceremonies for this Telenovela show in which Miss Modenna M. Brossard, employed by the United Cerebral Palsy Association of Bexar County, San Antonio, Texas, demonstrated the therapeutic use of parallel bars for young Pete Barrientos. Miss Brossard completed her advanced training in cerebral palsy with the assistance of a grant from the Elks National Foundation.



Recent Elks National Foundation awards:

Miss Renate Nothman, sponsored by New Haven, Conn., Lodge, for a post-graduate course in cerebral palsy therapy at Columbia University in New York.

John Ferree, sponsored by Louisville, Ky., Lodge, for advanced training in cerebral palsy therapy at Columbia University.

Miss Henrietta Baron, sponsored by Long Branch, N. J., Lodge, for advanced training in cerebral palsy therapy at Columbia University.

Joseph F. Gangemi, sponsored by Syracuse, N. Y., Lodge, for a course in special education at Syracuse University.

Norris W. Eastman, sponsored by Springfield, Mass., Lodge, for a course in adapted physical education and recreation at Springfield College.



With the help of Mrs. Rosemary Botta, this little boy at the Walter D. Matheny School for Cerebral Palsy Children, Far Hills, N. J., is learning to care for himself. Mrs. Botta took a post-graduate course in cerebral palsy at Columbia University in New York, made possible by a grant from the Elks National Foundation. Mrs. Botta was sponsored by Somerville, N. J., Lodge.

### *A Gift From The Heart Is Better Than The Rarest Jewel.*

If we had a million dollars, or a million, million dollars, we couldn't do all the fine deeds we would like to do. Of course, we haven't that kind of money. AND YET THERE IS SO MUCH TO BE DONE.

The meritorious demands made of us are terrific. AND WE SO WANT TO HELP! !

Since 1930, we have spent over \$1,000,000, from income alone, to help the needy in the following fields:

- Rehabilitation of physically handicapped children.
- Specialized training of personnel to staff Cerebral Palsy Treatment Centers.
- Hospitalization for tubercular patients.
- College scholarships to the ambitious, well qualified boys and girls of our community.
- Youth leadership activities.

You, my Brother, can help immeasurably, not only for your own personal satisfaction, but to the greater glory of our great and benevolent Order.

**WE APPEAL TO YOU! BE AS GENEROUS AS YOU CAN!**

Whatever you can give to our Foundation please forward to one of the following:

1. Your local Lodge chairman
2. John F. Malley, Chairman, Elks National Foundation, 16 Court Street, Boston 8, Mass.
3. John J. Rocco, Chairman, 70 Revere Street, Everett 49, Mass.

This well-thought-out appeal on behalf of the Elks National Foundation was prepared as a special bulletin recently by the Massachusetts Elks Association for its 1956-1957 Fund Campaign for the Foundation.

## You don't need to pay \$250 to \$300 for **INCONSPICUOUS ...QUALITY HEARING AIDS!**

Zenith offers the World's Largest-Selling, Finest Quality Hearing Aids at \$65 to \$165



If you are hard-of-hearing, you want a hearing aid that is inconspicuous... something really new and different!

That's why some manufacturers and dealers use such alluring phrases as "a miracle of concealed hearing" . . . and other exaggerated claims. But the difference that *counts* is price!

How can Zenith offer the finest quality at such sensible prices? If Zenith paid commissions of \$145 to \$160, as some do, even our \$65 model would have to sell for over \$200! And every Zenith is sold on a genuine Ten-Day Money-Back Guarantee!

See the new 4- and 5-transistor Zenith models at your nearby Zenith Hearing Aid Dealer, listed in classified phone book. Or mail coupon for free catalog and dealer list.



By the Makers of World-Famous Zenith TV, Radios, Amazing "Space Command" TV Tuner

**SEND FOR FREE BOOKLET!**

Zenith Radio Corporation  
Hearing Aid Division, Dept. 27S  
5801 Dickens Avenue, Chicago 39, Illinois  
Please mail me your new FREE catalog on Zenith Hearing Aids and list of local dealers.

NAME \_\_\_\_\_  
ADDRESS \_\_\_\_\_  
CITY \_\_\_\_\_ ZONE \_\_\_\_\_ STATE \_\_\_\_\_

# SUGGESTION BOX



DROP HERE

Dear Mr. [unclear]  
April 23, 1957

~~\$~~28,000.  
REWARD  
for a good idea

found  
main  
lobby

## Bonus Paid, Highest Yet

The all time record bonus is \$28,000 paid by Cleveland Graphite to Charles Zamiska, a furnace operator who came up with an improved method for handling carbon cores to be used in the shell casting department. The previous year Dan Reba received \$12,104 for his exploratory work on the same process.



New Finishing Plant to be opened soon!



## Obscure but intelligent workers in big and small business are yielding a harvest of ideas for better products at less cost.

BY STANLEY FRANK

ILLUSTRATED BY DONALD F. MOSS

IF YOU ARE BAFFLED by any mechanical device more intricate than a zipper, you will be tickled to learn that the wheel has turned full circle in the race to maintain America's technological supremacy. The most important piece of equipment in industry today is a plain, wooden box that does not contain a single electronic tube or a complicated dohickus only a graduate physicist or engineer can understand.

This box is, in fact, empty every morning, but each night it yields a rich harvest of ideas that keep our economy operating at peak efficiency. For this is the old-fashioned suggestion box, still the best gadget ever invented for capitalizing on our most valuable national asset—the intelligence and initiative of our people.

In 1957, some 7,000 firms with organized suggestion systems will receive more than 8,000,000 ideas for turning out better products at cheaper cost. Virtually all the suggestions will come from obscure workers whose technical training has been limited to practical, on-the-job experience. And fully 25 per cent of the ideas submitted will be adopted by top executives who will be very happy indeed to give approximately \$65,000,000 in cash bonuses to smart, enterprising employees.

"Surveys of our members show that companies recover more than ten times the amounts of the bonuses," reveals Betty Cronenworth, secretary of the National Association of Suggestion Systems, in Chicago. "That estimate covers only savings in production methods, overhead costs and man-hours of work. It does not include benefits such as better public relations, higher morale among workers and safety measures. Those intangibles cannot be evaluated in dollars and cents, but they contribute enormously to a company's good will."

It must be sound business practice to reward handsomely a worker who has enough interest in his job to devote thought to it on his own time. A fast-growing trend among big corporations is to give employees a percentage of the net savings effected in the first year by the adoption of their ideas, less installation costs if re-tooling or the purchase of new machinery is involved. The awards range from 10 per cent up to the whopping 25 per cent given by the Cleveland Graphite Bronze Company—and they add up to a lot of money.

The all-time record bonus is \$28,006

paid by Cleveland Graphite in 1948 to Charles Zamiska, a furnace operator who came up with an improved method for handling carbon cores used in the shell casting department. The previous year Dan Reba received \$12,104 for his exploratory spadework in the same process.

The highest award in 1956 also was paid by Cleveland Graphite to Hal Rogers, who collected \$10,229 for an inspiration which seized him while he was eating his lunch in the shade of the plant building. Rogers idly noticed that the pull rolls from four big milling machines, which had been discarded as obsolete, were stored temporarily under a canvas until they could be carted away to the junk pile.

"It suddenly occurred to me that those discarded rolls could do the job as well as the new machinery the company was going to buy," Rogers relates. "So I just made a few preliminary sketches, outlined the idea in general and dropped it in a suggestion box. Next thing I knew, it was adopted and I got a check for \$1,100. Later, the net savings were computed and I learned I was entitled to a total bonus of \$10,229. That was quite a windfall for a couple of hours of extra work."

In the last dozen years Cleveland Graphite has paid \$77,692 for just thirteen of the thousands of ideas poured into its suggestion boxes. "Those little receptacles placed all around the plants have been a tremendous factor in the growth of the company," says Frank J. Carbon, head of the firm's suggestion system. "Their impact on relations between management and labor has been even more important than the very substantial savings we've realized. An employee derives much greater satisfaction from his job when he is provided with an opportunity for contributing to, and participating in, a successful operation. It gives him a sense of belonging which promotes loyalty to the company."

THE cushy dividends accruing from suggestion boxes is not confined to stockholders in profit-making corporations. Every citizen in the United States is benefiting appreciably by the extension of such programs. The largest, and most enthusiastic, advocate of suggestion boxes is the largest business in the country—the federal government. Sure, taxes are fierce, but all of us are spared much more painful bites

out of our paychecks only because a new policy permits 250 government agencies to follow the lead of private enterprise.

Since November 30, 1954, suggestions submitted by government workers have cut federal expenditures by a quarter of a billion dollars. On that date Congress passed the Employees' Incentive Awards Act authorizing the Civil Service Commission to pay bonuses for money-saving ideas. It was no coincidence that in 1956, the first full fiscal year the Act was on the books, there was a 35 per cent increase in suggestions received—and a 38 per cent increase in resulting dollar benefits. Bonuses totaling \$5,888,531 brought economies amounting to \$69,603,566.

"The American people bought the biggest bargain in their history—and I mean bargain in the best sense of the word," George M. Moore, Civil Service Commissioner, declared last November. Mr. Moore hardly was guilty of overstatement.

Everyone gripes about red tape, but Ruby Finch, a clerk in the Detroit office of the Army's Ordnance Tank-Automotive Command, finally did something about it. She devised a streamlined plan for keeping a world-wide inventory on spare parts for the armed forces that annually cuts forty-six million inches off lists recorded on tapes. Herbert Poenish, a civilian who tackled a similar problem for the Engineering Corps, could have retired for life had he been working for a private company that gives a bonus of 10 per cent for the first year's savings on an improved method. Poenish's scheme for processing replacement parts used in the Army's engineering equipment reduced overhead costs by \$5,500,000 annually. His bonus of \$1,700 was one of the largest ever awarded to a government employee.

Former servicemen can thank Richard J. Kuhn, a document analyst in the Veterans Administration, for the faster action they are getting on applications for benefits. Requests previously were subject to long, annoying delays because so many fraudulent claims were presented that discharge papers and other official records had to be examined painstakingly for alterations and erasures. Kuhn rigged up from salvaged equipment an electronic magic-eye machine that exposes any doctored document.

Kuhn received \$1,000 for his invention,  
(Continued on page 51)



# *Danger Struck*

BY CHARLES YERKOW

*Davie played the roles of Marshal Earp and Doc Holliday. Then the real thing came along.*





**ILLUSTRATED BY JOHN McDERMOTT**

*The interior of the bar appeared awfully dark to Davie Vernon, menacing, outright forbidding.*

**T**HAT evening at nine-thirty when he was supposed to be at home studying for the mid-term exams, Davie Vernon was seated alone in one of the high-backed booths of Mr. McHugh's soda parlor. Davie was not unaware of his own feeling of guilt, waiting here to meet Eileen in direct disobedience of his parents. Not that his father or mother minded his taking Eileen to a movie or for a soda; nor was it as if he were out with a gang getting into trouble. Davie's parents simply wanted him to make a good showing in the mid-terms.

Davie had already lost interest in the

cherry soda resting on the table before him. His back was to the street. He glanced impatiently at the ornamental mirror strip on the rear wall, there seeing a view of the store doorway and the glass candy showcase up front. No Eileen, though.

Mr. McHugh, the genial elderly proprietor, usually closed by ten, which, as he'd often said, gave him a little time at home with Mrs. McHugh and Billy. Davie and Billy were in the same class in high school. At the moment Mr. McHugh was cleaning up in back of the fountain, the place empty, except for Davie.

"I just got," Mr. McHugh called over

to Davie, "a copy of 'Guns at West Rock', Davie. Ever read it?"

Davie said, "I'm not reading any of 'em right now, Mr. McHugh. Mid-terms."

The proprietor grinned. "Sure. I forgot. I'll let you have 'Guns at West Rock' when I finish."

"Okay," Davie said absently.

Thus reminded, and with time on his hands, Davie Vernon momentarily let his mind edge over to the episode in the last book he'd read, the one in which Wyatt Earp and—

"Are you sure Eileen is meeting you  
(Continued on page 36)

# Young Tigers

**W**AY BACK IN 1940 Jack Zeller, then overseer of the Detroit farm hands, called a fledgling catcher to one side:

"You're not going anywhere in baseball; you can't hit well enough. But you do have the brains and drive to become a fine manager, maybe a big league manager."

The youngster was John Thomas (Jack) Tighe, pronounced Tie, the new manager of the Detroit Tigers, a franchise generally rated as one of the most valuable in either big league.

Tighe, a smiling, balding Irishman who looks a bit like Joe McCarthy, heired a club that has finished in the second division for six consecutive seasons, also a club that trailed the Yankees of 1956 by a whopping margin of 15 games. Furthermore, attendance last summer slumped from 1,181,838 in 1955 to 1,051,182, a very ordinary piece of business in spacious Briggs Stadium.

Yet Jack Tighe now finds himself swept along on the greatest wave of Detroit optimism in a decade. And he doesn't seem to mind at all. The cash customers are only slightly more optimistic than the manager.

"We won't finish any worse than second," Tighe told the owners last December. At the training camp at Lakeland, Fla., in mid-March, I asked him if he still thought the Tigers would finish second.

"I do," he said emphatically, "and I

think we might possibly even do better!"

Tighe saw nothing in the daily exhibition games, even the ones with the redoubtable New York Yankees, to induce a state of shock. He has told his players they can win the pennant. Such optimism was contagious. Newspapermen interviewed him daily, talked to his young stars, reminisced with the few old-timers still around and met the ambitious rookies.

There was a new spring in every step and the early-bird fans now insist that Detroit has a great chance to take the pennant away from the Yankees. These partisans make Lakeland their winter home—Michigan car tags were almost as common around the camp as Florida plates. This year the pilgrimage to Lakeland was the biggest ever: back in Detroit advance ticket sales boomed, showing a pre-season increase of 25 per cent over the 1956 season.

The skeptics wonder—and have every right to—why the Tigers, who won only 82 games last season, can be tagged as a serious challenger. The reasons are four-fold . . .

First, the makeup of the American League favors a young and brash rival.

The Cleveland Indians, having failed often, are older and slower. The same goes for the Chicago White Sox, who may suffer without Frank Lane's smart trading touch, and the Boston Red Sox still have aches and pains in the infield.

Second, the Tigers have new owners, a new organization and a firm determination to produce a winner. An 11-man syndicate, of which more later, shelled out \$5,500,000 for this club, an all-time high in baseball. These investors can get their money back only if they put the Tigers in the World Series. It's that simple.

Third, the Detroit finish in 1956. At  
(Continued on page 47)

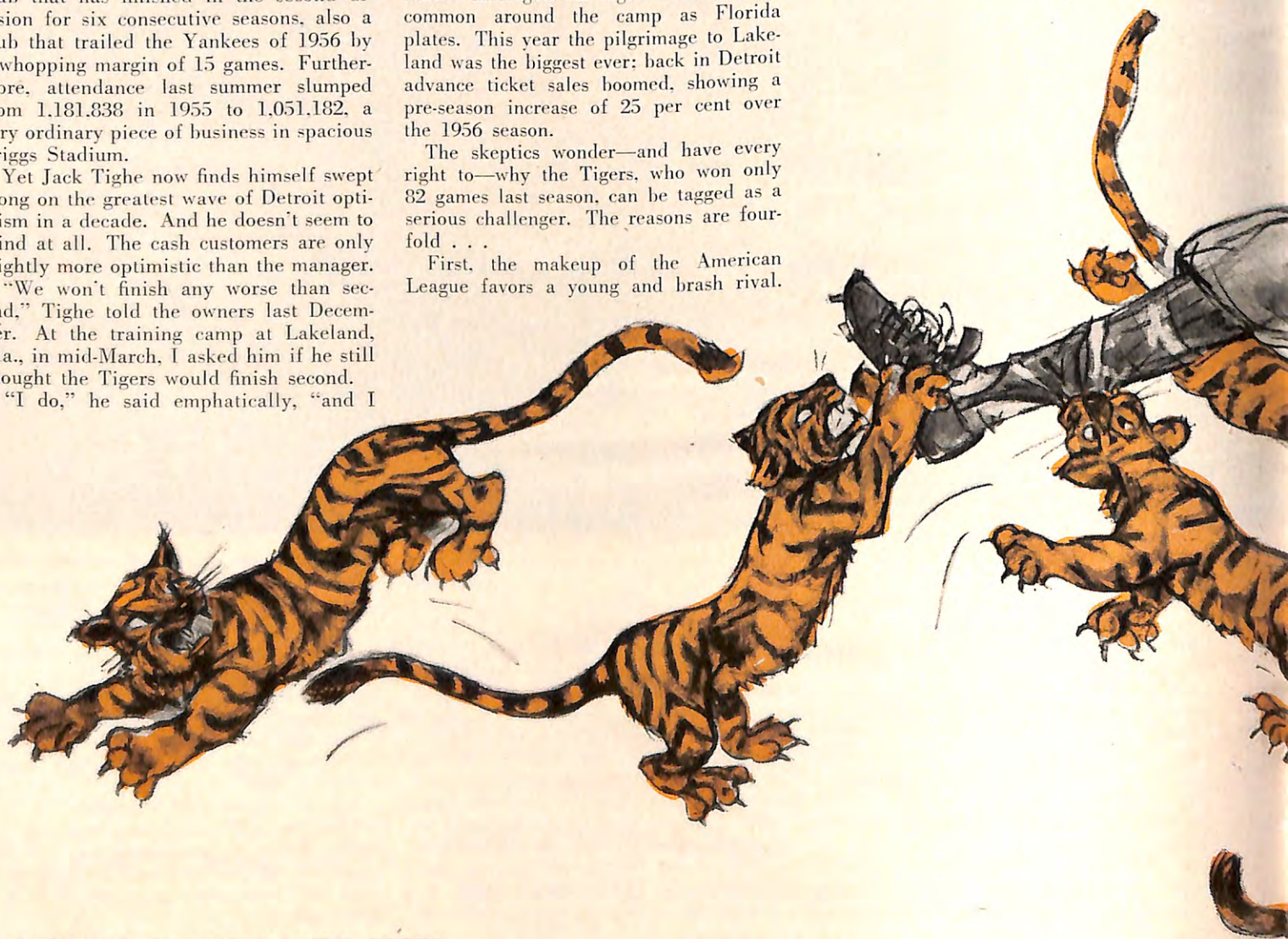

ILLUSTRATED BY WILLIAM VON RIEGEN

# in a Hurry!

BY TOM SILER

**In Detroit there are new owners,  
a new organization and a  
rookie manager—all with a firm  
determination to produce a winner.**





# The Heedless

*The thoughtless highway slaughter of our wild life creatures totals tens of millions yearly.*

BY WILLIAM BYRON MOWERY

LATE one evening I got into my car at a bus-terminal town an hour out of New York City and drove the thirty miles on home, through a Sleepy Valley country of wooded hills, old farm valleys and moon-gleaming lakes. The drive should have been pleasant and enjoyable. It was the witching hour of two o'clock and the night was coldly beautiful, with a new snow turning the countryside to dark silver and a bright moon drifting through a broken

field of woolpack high in the western sky.

But death had danced a macabre jig among the wild creatures along that stretch of road. Time after time I slowed down and jotted a sad little statistic onto the record board beside me. Here in a rock cut a raccoon, of a family I had often seen playing there, lay dead on the road shoulder. Farther on a big fat possum had been hit, though it wasn't dead yet—unfortunately. Down in the next valley a pair of

rabbits, evidently at their courting in the road, had been run over. . . . Altogether, fourteen such entries on that thirty-mile drive.

Also, I had to pass the small stone bridge in a wooded valley where I had been the person, one night last winter, to come upon a wrecked car and its dead driver. Just a few minutes earlier he had come tearing around a bend, doing fifty on a slick, winding night road, and gone whizzing past me. At the bridge, where he hit a doe, skidded and crashed into the stone abutment, destiny had caught up.

Everywhere these days, in newspapers, magazines and over the air, the heavy toll that automobiles are taking in human life and injury is being dinned at us constantly, as it should be, but about the highway



Illustrated by GEOFFREY BIGGS

# Horsemen

slaughter of our wild creatures, literally by the tens of millions, we never hear one word. They have no defense, no voice, no way of asking us, please, to give a little thought to this carnage among their ranks, so I am going to be their spokesman and plead their cause here. I want to discuss their night ways a bit, then take you on a drive and show, by actual demonstration, how we can cut this carnage to a small fraction of what it is now.

And incidentally—or maybe it's not so incidental—I will show you that one of the lives we save may sometime, in very truth, be yours or mine. Our safety and theirs are tied up in one bundle.

I suppose there are a few individuals who will shrug and say, "So some animals get killed—so what?" But the great ma-

jority of people hate it when they run over some wild creature, and they wish they could somehow avoid such accidents. Also, they don't like the danger, ever present in deer country, of winding up themselves against some stone abutment or rolling down over a throughway embankment.

As roads and cars get faster, and especially as these modern roads are being extended into big-game country, highway authorities are finding themselves bedevilled by the problem of the human casualties resulting from collisions with animals like deer and bear. This type of casualty is steadily mounting and no method yet devised, such as fencing, offers any genuine remedy. In a short time after its operation began one of our Eastern throughways had upward of a thousand "deer accidents."

Just consider what this problem is going to be when we get that huge national network of fast highways.

Emphatically, this vast and increasing destruction of our wildlife, along with the human casualties involved, is *not* something we just have to accept, as an inevitable, gory part of the automobile age. *Four times out of five we can avoid running into or running over these wild creatures.* If we know how. If we know a few wildlife facts, which I will give, and know a special trick or two with the steering wheel at night.

**W**HEN I first began studying this matter of animal fatalities on the highways, I immediately ran into several puzzles. (Continued on page 40)

## "DEVELOP ELKDOM'S RESOURCES"

VISITS with thousands of Elks in every section of our nation enthuse me with the potentialities of our great Order.

Elkdom has tremendous programs and a sound organization based on 89 years of experience. Our manifold benevolent, educational, veterans' rehabilitation and patriotic activities, administered by our Grand Lodge and State Association officers, Commissions and Committees, all are channeled to the community level in our subordinate lodges.

They are designed for the protection of our American Heritage through the development of our Youth. Their worth is evidenced by the millions who are attracted to our ranks and are responsible for our steady growth. But there is a glaring weakness on our local levels deserving sober consideration.

Review of our membership statistics for the past five years shows that each year an average of 102,393 join our Order, 82,863 by initiation. These same years are offset by annual losses of 75,948, limiting our average net gain to only 26,446.

Of the losses, 41,809 are "dropped for non-payment of dues" and the percentage to initiations has risen each year.

True, selective membership will correct the first fault. Putting new members to work while they are freshly imbued with the spirit of Elkdom can correct the second fault.

Our new Exalted Rulers, installed last month, have the opportunity to block this loss if they will include these new Elks on the working committees and utilize the enthusiasm which prompted their affiliation.

However, if the local lodges do not have active programs they can not absorb this new manpower. Therefore, that becomes the first obligation.

Programs of activity are usually dependent upon secretaries who are reimbursed for their efforts. The importance of these secretaries as administrators as well as Elks can not be stressed too strongly. They have a twofold obligation in the dispatch of their responsibilities and opportunities for our great Order and can be one of the most effective factors in maintaining and expanding membership.

I have faith that our new Exalted Rulers will start the ball rolling at once with inspired programs, proper indoctrination and assimilation of new members, and thus contribute to the growth of our splendid Order.

Very sincerely,



GRAND EXALTED RULER



## A Message from the Grand Exalted Ruler

"A STRONGER ELKDOM FOR A BETTER AMERICA"

# REMEMBRANCE STRIKES THE MATCH IN KOREA

through your National Service Commission



DEPARTMENT OF THE ARMY  
OFFICE OF THE ADJUTANT GENERAL  
WASHINGTON 25, D. C.

IN REPLY REFER TO  
AGMZ-P 005 (15 Feb 57)

The Elks National Service Commission  
2860 Chrysler Building, North  
New York, New York

Gentlemen:

I am happy to note the continued activity on the part of your commission in donating cigarettes to military personnel in Korea. May I once again, on behalf of the Honorable Wilber M. Brucker, Secretary of the Army, impart the gratitude of Department of the Army for your noteworthy contributions which are reaching so many hundreds of our personnel.

With the return to more normal conditions in Korea, it is understandable that the thoughts of many folks here in the United States would no longer be of servicemen in that country. However, the fact remains that many of our troops are still serving on that first line of defense. It is with these thoughts in mind that knowledge of your continued, consistent, and extremely generous contributions to the welfare of those personnel in Korea can be especially appreciated not only by Department of the Army here in Washington but also by our soldiers in Korea.

Your donations of cigarettes since the end of 1953, as reported to this office by the R. J. Reynolds Tobacco Company, now total 3,600,000.

With this letter may I again convey to you my sincere thanks, as well as those of the commander of forces in the Far East, for your continued thoughtfulness.

Sincerely yours,

A handwritten signature in cursive script that reads "Herbert M. Jones". To the right of the signature is a small circular stamp or mark.

HERBERT M. JONES  
Major General, USA  
The Adjutant General

Korea is still very real. To America it is a vital outpost that must be garrisoned and patrolled.

Korean duty for a serviceman is lonesome. Since defense activities in the Far East cannot be made public, it follows that any morale problems in this remote part of the world receive little attention.

Since the start of hostilities in Korea, your National

Service Commission has sent, and will continue to send, millions of cigarettes to these lonely G.I.'s.

Thousands of cards and letters of appreciation express eloquently the gratitude of these men. We have published excerpts from these messages before; this time, we are reprinting a letter which proves their superiors also appreciate your interest in the men they command.

# RETIRE IN MEXICO ON \$150 A MONTH

or less in a resort area, 365 days of sun a year, dry temp. 65-80°. Or maintain lux. villa, servants, ALL expenses \$200-250 a mo. Am.-Eng. colony on lake 60 mi. long. 30 min. to city of 1/2 million, medical center. Schools, arts, sports. Few hours by air. Train, bus, PAVED roads all the way. Full-time servants, maids, cooks, \$7 to \$15 a mo., filet mignon 50c lb., coffee 45c, gas 15c gal. Gin, rum, brandy 65c-85c fth., whiskey \$2.50 qt. Houses \$10 mo. up. No fog, smog, confusion, jitters. Serene living among world's most considerate people. For EXACTLY how Americans are living on \$50-\$90-\$150-\$250 a mo., Airmail \$2.00 for COMPLETE current information, photos, prices, roads, hotels, hunting, fishing, vacationing and living conditions from Am. viewpoint (Pers. Chk. OK) to Bob Thayer, Box 12D, Ajijic, Jal., Mexico. (Allow 2 weeks for delivery.)



## HERE'S YOUR HOME AWAY FROM HOME— WHEN IN MILWAUKEE

Milwaukee, Wisc., Elks Lodge gives you all the conveniences of a fine hotel plus a warmth and friendliness while not obtrusive is here and yours for the asking. There are features too, that you won't find in the average hotel, swimming pool, gymnasium, lockers, steam room, massage and light treatments available. Ladies rest room, private dining and meeting rooms and a spacious Marine dining room. Rooms for cards, billiards and general recreation and a well stocked library. Bowling, of course and the alleys are good. All open to Elks and their guests. Hotel rooms are stag. Roof provides sunbathing and there are horse shoe courts. To enjoy a good time in Milwaukee, to live comfortably and pleasantly stay at the No. 46 Lodge.

24 well-equipped rooms,  
many with baths

Good food in our handsome Rainbow Lounge prepared by our own chef noted for excellent cuisine.

SCRANTON, Pa., No. 123

A few accommodations available.  
Advance notice appreciated.



## VISITING MIAMI BEACH? HAVE FUN AT 1601

Experience real Southern Hospitality at your Elks Lodge in the playground of America. Unsurpassed location overlooking beautiful Biscayne Bay. Attractive bar and recreation rooms. Sandwiches and light snacks served until midnight. Vacationing Elks and their ladies always welcome.

720 West Avenue

Miami Beach, Fla.

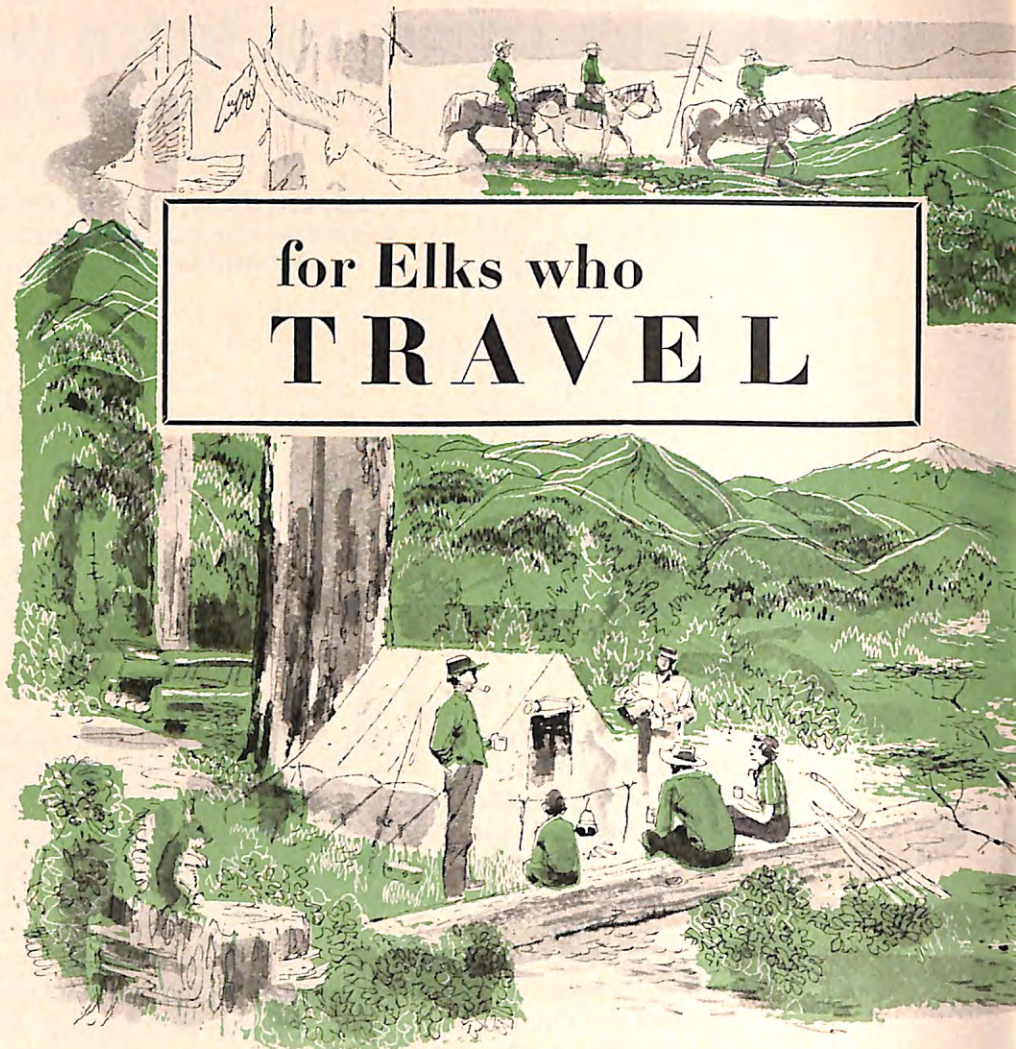

# for Elks who TRAVEL

Some of the country's great national parks  
are easily reached from our Convention City.

BY HORACE SUTTON

ILLUSTRATED BY H. B. VESTAL

IT ONLY TAKES ONE ROBIN or one crocus before the folders are being unfolded on the floor, and with the Elks convening by the Golden Gate this summer, July 14-18, what should be carpeting your living room now are maps of the scenic lands that stretch north, east and south of San Francisco.

Here are some of the possibilities for excursions on the way to San Francisco or on the way home. First of all, north of the city by the Bay stretches the Redwood Empire, a majestic land covered by a million and a half acres of Redwood forests. Some 97 per cent of all the world's giant sequoias, a species that once grew in Eastern Europe and Siberia grow here now. They are the tallest living things on earth, the highest of them, the Founders Tree, stretching 364 feet high. (Some Australian partisans had claimed years ago that eucalyptuses Down Under were growing higher, but scientific measurers went into the field and the Aussie claims have since been withdrawn.)

From March until July the Redwood

Empire blooms with apple, pear, prune and other varieties of fruit trees. The wild lilac, poppies and buttercups, the lilies, mustard and dogwood ignite the plain, and the gladioli burst into colorful clusters near Grants Pass in Oregon, which is the northern gateway to the Redwood Empire for those who live above it. Besides the tonic value of the beautiful scenery, the Empire also encloses a variety of mineral springs in Napa, Lake, Sonoma and Mendocino Counties. First popular with the Indians, the mud and sulphur baths are popular with the pale-faces who take the waters (and the mud) for the relief of arthritis, rheumatism, sciatica, fatigue, etc.

One park on the road from the north country down to San Francisco is Crater Lake National Park, whose centerpiece is a magnificent lake inside the crater of an extinct volcano. Once a mountain that probably crumbled after it blew its top, Crater is now a center for visitors who cluster at Rim Village, a settlement perched at 7,100 feet. The lake itself is





loaded with rainbow trout, and silverside salmon, but you'll have to troll from a boat and use a 350-foot line. The lake is 2,000 feet deep. Shore fishing with dry flies is best in August and September. From Rim Village it's a crooked route down a mile and a half to the water's edge where you can rent boats for rowing or fishing. Twice a day a boat makes a sightseeing tour around the lake and a park naturalist goes along on one trip and points out such blossoms as Creeping Raspberry, or Pussypaws. Crater Lake Lodge at Rim Village has rooms at anywhere from \$7 to \$11, or less if you will do without a private bath. Sleeping cabins are as little as \$3 and that includes the bedding. The famous Shasta Route of the Southern Pacific, operating between Portland and San Francisco, drops passengers at Klamath Falls whence the Crater Lake bus will fetch you to the lodge. Elks and their families planning to go to the Convention aboard Northern Pacific's Grand Exalted Ruler's Special Train leaving Chicago on July 8th will enjoy this great scenic ride on July 13th from Portland to Oakland.

Farther south, the Lassen Volcanic National Park houses the only recently active volcano on the mainland of the U.S. (It was exploding as recently as 1921.) It opens usually late in May, runs through mid-September, and there is hiking, boat-

ing, horseback riding, and fishing too, although here you will need a California license. The park gateway is Redding, forty-five miles away, a lumber and shipping center and the seat of Shasta County. Gray Line Tours also runs a sidetrip from Redding to the Shasta Dam which includes a tour of the lake of the dam on a cruiser. Shasta is higher than the Washington Monument and the water drop over the spillway is three times longer than Niagara Falls.

Between Lassen Park and Yosemite Park, covering the state border between California and Nevada where it breaks in its familiar western angle, is Lake Tahoe, a touring possibility for those who want to roll out of San Francisco along Route 40. The possibilities are endless, what with Truckee, Reno and Carson City all within easy striking distance.

As for Yosemite, one of the most famous of all parks, it lies virtually due east of San Francisco, an awesome preserve of granite walls, tumbling falls, and huge trees, all of it embracing no less than 1,189 miles, enough to make a fair sized principality. Here again there are hikes sometimes led by a park naturalist; there are not only horseback riding but overnight saddle trips. Bus companies run motor tours touching the highlights within the park. And besides all this, there are

(Continued on page 34)

## IN BOISE— for ELKS only

Boise, Idaho, No. 310 invites you to stay at its comfortable lodge home.

Appetizing lunches served and an excellent cuisine. Liquid refreshments available and all smoking materials you need. A well appointed ladies' lounge on main floor and ample facilities for cards, pool and billiards. Dances every Saturday. So when in Boise stop at the "Friendly Lodge" where a truly friendly welcome awaits you. And rates are reasonable too.

**B. P. O. ELKS—No. 310**  
Boise, Idaho—821 Jefferson Street



### You'll Remember LAS VEGAS

When you stop at Las Vegas, New Mexico B.P.O. Elks No. 408 you'll find true club life and a friendly greeting. More like a home than a hotel. Eight rooms available most of the time—and if price concerns you, forget it—the rates are very reasonable. Hotel rooms restricted to Elks only. Sorry, no facilities for their ladies. Bar and it serves snack meals. When in this locality give our good club a try. We think you'll like it.

### BE AT EASE IN BOZEMAN, MONT.

We keep a few home-like rooms for traveling Elks and the rates are only \$2.00 to \$2.50 per day. No meals served but there are plenty of good eating places accessible. You'll like our lodge and the brother Elks you'll find here. When in Bozeman why not stay with your kind of people, members of the Elks who have the same interests that are yours?

**BOZEMAN B. P. O. ELKS No. 463**



### FLORENCE SAYS "HOWDY"

Florence, Colorado, B. P. O. Elks No. 611 offers traveling Elks and their ladies 21 excellent rooms and comfortable surroundings. No food served but convenient restaurant facilities available. Room rates \$2 per night. Liquors served. You'll find Florence lodge a fine stopping off place where a warm welcome awaits you.

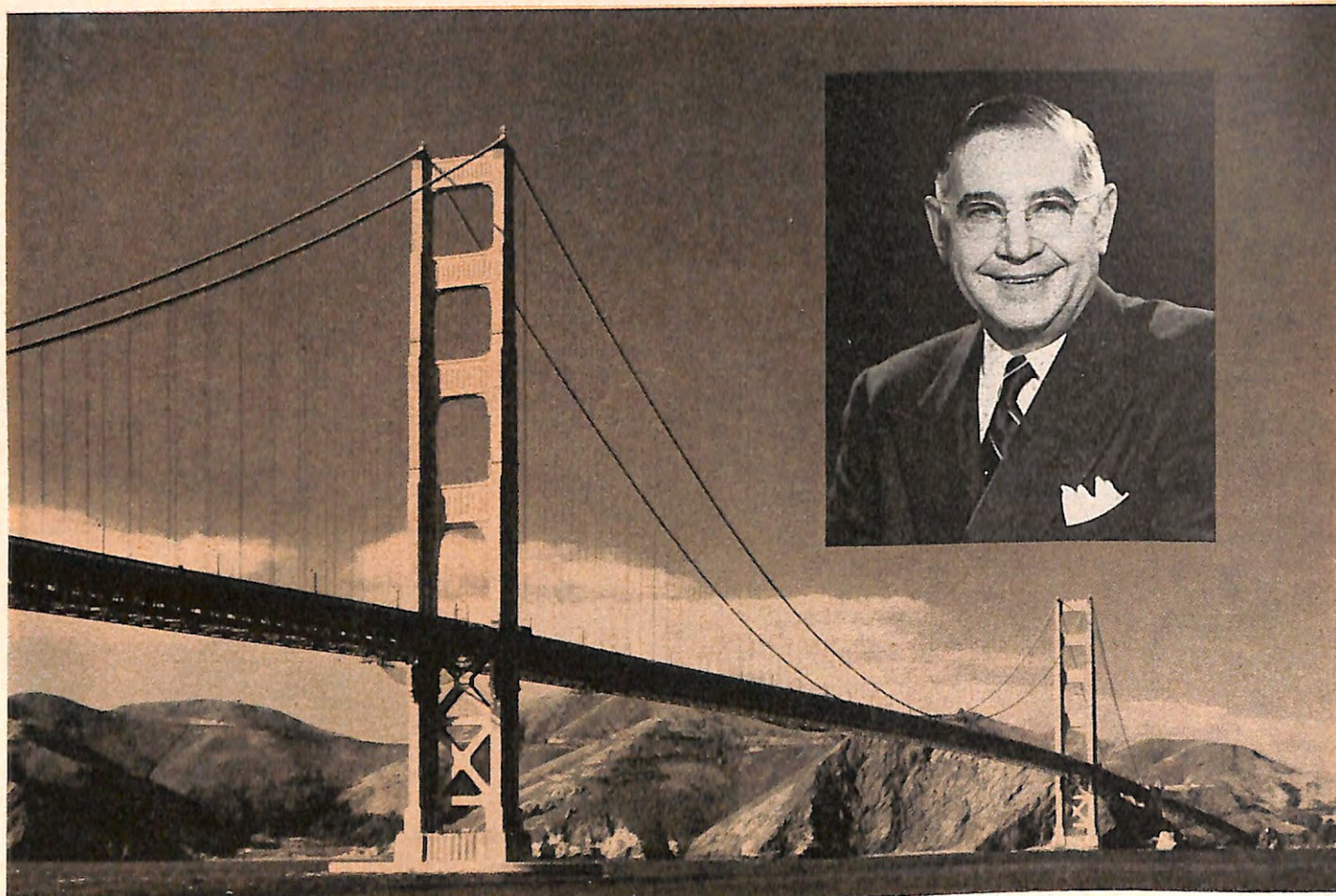

## Welcome to the Convention in San Francisco

Come Westward to California, Brother Elk.

All of the 128 Elks Lodges of California join with San Francisco Lodge No. 3 in cordially inviting you to be our guest at the 93rd Grand Lodge Convention which will open in San Francisco on Sunday, July 14, 1957, and continue through Thursday, July 18th.

San Francisco is rich in the early history of the West.

See the famous Golden Gate Park.

See the stupendous Golden Gate and Bay Bridges.

Enjoy San Francisco's Bohemian atmosphere and its renowned cafes and restaurants.

Visit the giant redwoods.

See the University of California at Berkeley and Stanford University at Palo Alto.

Plan to see Monterey Peninsula, Cypress Point, Pebble Beach and the Carmel Mission.

Then plan to travel south to Santa Barbara, Los Angeles, Hollywood, the South Coast beaches, San Diego and across the line into old Mexico.

San Francisco's climate in July is cool and invigorating and you need not worry about heat or humidity.

The lodges of the Bay District of California are cooperating with San Francisco Lodge to provide you with the finest of convention entertainment. 125,000 California Elks sincerely welcome you to San Francisco in July.

*Sincerely and fraternally,*

L. A. LEWIS

*Past Grand Exalted Ruler*

**Convention Date: July 14-18, 1957**

# ROD & GUN

BY TED TRUEBLOOD

**A sportsman needs only his gun  
and a call to have a chance to  
bag a coyote, bobcat or fox.**

ONCE when I was a boy I caught a jack rabbit in a steel trap. It was an accident—rabbits actually are hard to catch in traps of this type—and I decided to turn him loose. He crouched motionless as I approached, and I grabbed him by the ears to hold him while I depressed the spring of the trap with one foot and opened the jaws with the other hand.

The instant I touched him, he began uttering the most agonizing screams I had ever heard. They were shrill, high-pitched, and each of them lasted only a second or two, but one followed the other in rapid succession until he had shrieked about a dozen times. He then paused, apparently to catch his breath, and was just starting again when I got his foot out of the trap and turned him loose.

I was standing there, watching him hop away, when I saw a movement on the ridge about 75 yards beyond. It was a coyote. He had trotted up from the other side and now he was stopped on top, looking eagerly in my direction. I had leaned my .22 rifle against a sagebrush several feet away to release the rabbit. Before I could reach it, the coyote apparently saw me, whirled around and disappeared back behind the ridge.

If I had been a boy genius—or maybe even normally smart—I undoubtedly would have put two and two together and profited therefrom. Instead, it never occurred to me that the coyote's appearing at that particular moment was anything but coincidence. It was another 30 years or more before I intentionally called up my first coyote by imitating the shrieking of a terrified or dying rabbit.

Meanwhile, down in Texas, a few hunters and cow punchers had somehow made the connection. Maybe one of them had an experience similar to mine and was clever enough to guess the real reason for the coyote's approach. They learned to imitate a rabbit's squalls, using only their mouths and vocal cords. Then they discovered that if they took the tin noise maker out of certain rubber toys, pressed it against their lips and blew on it hard,



*Ted Trueblood with a coyote that couldn't resist the dying rabbit call.*

the sound that emerged was a pretty good imitation of a rabbit's shrieks.

Hart Stilwell wrote an article about this time that he titled "Calling The Killers." He described the methods, and the amazing results, and more sportsmen began to get interested. The next step was inevitable. You could soon buy a call made specifically to imitate the shrieks of a terrified rabbit and guaranteed to attract coyotes, foxes, bobcats and anything else that preys on our little short-tailed, long-eared friends. That, of course, includes just about every meat eater, both large and small, that inhabits North America.

For several years now, the Burnham Brothers, of Marble Falls, Texas, and A. L. Lindsey, of Brownwood, in the same state, have been marketing such calls. My friend Byron Dalrymple says this is the most significant development in hunting of the post-war period, and he may easily be right. Before the advent of these calls, it was only by the most outlandish luck that a hunter ever saw any member of the cat family—unless, of course, he was actually hunting them with hounds. And most sportsmen do well to maintain

a pointing dog, a retriever or a beagle. They certainly can't afford to train nor keep a pair of hounds against the rare times when they might make a trip for cats.

To a lesser degree the same thing applies to fox and coyote. Of course, we've all seen one or the other, or both, occasionally while hunting upland game or deer. But they were usually out of range, or we caught only a fleeting glimpse of them with no opportunity to get off a decent shot. The dying-rabbit calls have changed all this. Now any sportsman needs only his gun and a call to have a chance to bag a bobcat, coyote or fox. And if he lives in an area where these predators are abundant, that chance is better than good. The calls have provided the average guy with a chance for sport the year around, with special emphasis on that normally blank period between the end of duck season and the beginning of fishing.

If I am to be completely honest, I probably should confess here that I still remained skeptical, even after the calls  
(Continued on page 46)

# News of the Lodges



Photographed at the dinner marking the 75th Anniversary of Washington, D. C., Lodge were, left to right, P.E.R. and Publicity Chairman Ambrose A. Durkin, E.R. Joseph P. Gamble, U. S. Congressman Russell V. Mack, P.E.R. of Aberdeen, Wash., Lodge who was the principal speaker, General Chairman and P.E.R. Joseph G. Motyka, and P.E.R. and Secy. Rosell T. Pickrel. Congressman Mack, Mr. Durkin and Mr. Pickrel are former Grand Lodge Committeemen.

## Washington, D. C., Elks Mark Diamond Jubilee

U. S. Rep. Russell V. Mack, a P.E.R. of Aberdeen, Wash., Lodge and a former member of the Grand Lodge State Associations Committee, was an inspired speaker at the banquet marking the 75th Anniversary of Washington, D. C., Lodge, No. 15. The event, a dinner-dance, took place on February 21st at the Sheraton-Park Hotel when General Chairman P.E.R. Joseph G. Motyka welcomed the lodge's

500 guests and E.R. Joseph P. Gamble served as Toastmaster. The publicity features of the observance were capably handled by P.E.R. Ambrose A. Durkin, former Grand Lodge Committeeman.

On Feb. 12th, the anniversary had been celebrated at a closed meeting when a class of 85 was initiated by P.E.R.'s of the lodge in honor of Past Grand Exalted Ruler Robert South Barrett. Dr. Barrett was also on hand for the dinner-dance and delivered a stirring address. Among the

guests were 92-year-old John Pierpoint, a member for 55 years, and 85-year-old John V. Schmitt, a half-century Elk, and D.D.'s Charles L. Mobley and Lloyd Pahlman.

In his message, written into the Congressional Record by U. S. Sen. J. Glenn Beall, Congressman Mack explained the ideals of Elkdom in eloquent terms, stressing the splendid character of Washington Lodge which has grown from 41 Charter Members to more than 2,200 today. Pointing to the fact that other organizations had found it advantageous to provide a sort of national building where their members might assemble on visits to the Nation's Capital, Mr. Mack suggested that the Order of Elks direct its attention to the erection of such a building.

A leader in civic, fraternal, charitable and patriotic activities of Washington for many years No. 15 has been active in financing and organizing the new Youth Camp for underprivileged children.

## Michigan Elks Launch Laudable Major Project

The Michigan Elks Assn. has joined other State Elk groups in the adoption of a special program of benevolence. At its 1956 Convention last June, Pres. Robert A. Burns was authorized to appoint a five-man Major Project Commission to select and administer a special program for the Association. Scheduled to be rotated over a period of five years, it is composed of Past Pres. Hugh L. Hartley as Chairman, Dr. M. J. Kennebeck as Secy., and Carl H. Fernstrum, L. M. Richards and Philip Barney, with Mr. Burns and Vice-Pres.-at-Large Nelson H. VanDongen as ex-officio members. The Commission held its first conference at the Fall Round-Up of the Upper Peninsula Elks in September. A definite plan was decided upon, and Chairman Hartley presented that plan to the delegates at the State Assn.'s Midwinter Meeting in



The Charter Officers of Downey, Calif., Lodge, No. 2020, led by E.R. Larry Stevens, were photographed as they took the oath administered by Past Grand Exalted Ruler L. A. Lewis during ceremonies held at El Rancho High School in Rivera. Huntington Park Lodge officials assisted Mr. Lewis in instituting the new lodge which began its existence with 308 new members and 196 on transfer dimit.

ADDRESS OF GRAND EXALTED RULER FRED L. BOHN: Rooms 121-122, Zane Hotel, Zanesville, Ohio  
ADDRESS OF GRAND SECRETARY LEE A. DONALDSON: Elks National Memorial Building, 2750 Lake View Ave., Chicago 14, Ill.



E.R. M. D. McKay, center, presents to Chairman Hugh L. Hartley of the Michigan Elks Assn.'s Major Project Commission, left, Albion, Mich., Lodge's \$275 gift for the new State program for handicapped children. Looking on at right is State Pres. Robert A. Burns.



E.R. Hugh E. Gentili of Pawtucket, R. I., Lodge, third from left, congratulates Lt. Gov. Armand H. Cote, second from left, on his initiation into the Order as a member of a class named in honor of State Pres. Dr. Edward C. Morin, left. At right is D.D. Fred Quattromani.

Niles. The 400 members present accepted the plan with enthusiasm and unanimously adopted a resolution authorizing a \$1.00 assessment of all Michigan Elks, to be earmarked for this program.

Initiated on a modest scale, the plan calls for the use of three Michigan hospitals as centers for providing clinical and diagnostic assistance to handicapped children. The service will be expanded gradually as the public becomes aware of its existence and the sustaining interest of every lodge is assured.

Following diagnosis, a full report including the doctors' suggestions as to what can be done for each child, how long it should take to bring results and the expense involved will be made in writing to the parents by the Commission. Parents in the position to do so will be expected to pay; if the child is to be made a State case, the Elks will make the arrangements; if neither is possible, the Commission expects to be able to take on the obligation.

All lodges should appoint a Chairman for this work, and are asked to find worthy cases and arrange transportation to and from clinics. The Commission also plans the employment of a competent director in this field.

#### **Huron, S. D., Elks Provide Hotel for Community**

Feb. 19th, 1957, was a red-letter day in the history of Huron Lodge No. 444, and a vitally significant one to the entire community. It was on that day that the final bond was paid by the lodge to retire its indebtedness on the Marvin Hughitt Hotel.

For many years there had been a crying need for a hotel in Huron, but no group or organization was willing to undertake the responsibility. In 1919, far-sighted Huron Elks, desiring to give their community something of lasting benefit, decided to build the hotel to meet the demands of the rapidly growing city. Their perseverance and devotion to that goal resulted in the erection of the handsome, seven-story hotel which opened its doors in Sept., 1921, and has been the common meeting place for the community and its many visitors ever since. Containing 152 rooms, a ballroom which seats 350 per-



Hattiesburg, Miss., Lodge was the first organization of its kind in the State to receive a Tree Farm Certificate from the Mississippi Forestry Assn. The award was made at the lodge's Country Club where 1,340 of the lodge's 1,440 acres are covered by trees. Elk Trustees Chairman T. E. Rawls, fifth from right, accepted the award from Marion Stephens, Forestry Assn. Committeeman, fifth from left, in the presence of Elk and Forestry Assn. officials.

sons, several smaller dining rooms, lounge and coffee-shop, the Marvin Hughitt has a staff of 80, with an annual payroll of more than \$150,000. In 1956 over 600 regional and State-wide meetings were held within its walls with 20,000 registrations.

The financing of such a project was a huge undertaking and one that necessarily spanned a good many years of hard work. And so it is only right that the burning of the last bond was celebrated with special ceremonies and gaiety.



Cheektowaga, N. Y., Lodge, No. 2015, was instituted under the sponsorship of North Tonawanda Lodge with 79 Charter Members who elected James Plumery as their first Exalted Ruler. Officiating in the ceremonies were Past Grand Est. Lect. Knight J. Theodore Moses, Chairman James A. Gunn of the Grand Lodge Auditing Committee, State Pres. Francis P. Hart and Secy. Wm. R. L. Cook, National Convention Committee Director Franklin J. Fitzpatrick, D.D. Richard J. Gavagan, P.D.D.'s Erwin E. Hamann and Clifford A. McNaboe and Past State Vice-Pres. Joseph Bowen.

## LODGE NOTES

Final payment on Grand Island, Neb., Lodge's \$2,500 pledge to the Lutheran Hospital Building Fund was made by lodge Trustees Chairman P.E.R. H. E. Hallstead to Hospital Mgr. Emory Giannangelo in the presence of E.R. Earl L. Rembolt.

*D.D. Friend L. May reports that his home lodge of Clifton Forge, Va., is the first in the Southwest Dist. to attain Grand Exalted Ruler Bohn's membership quota.*

*With the opening of the 1957-58 lodge year, Frank J. Stickney began his 34th term as Secy. of Gardner, Mass., Lodge. A Charter Member, this devoted Elk has never missed a lodge meeting, Memorial Sunday, Flag Day, funeral or any other service of his lodge since his initiation in 1921.*

*D.D. and Mrs. Wm. F. McArdle were among the 200 persons who attended the "King and Queen Night" dinner and entertainment program marking the 52nd anniversary of Quincy, Mass., Lodge.*

Denison, Tex., Lodge is proud of the long service of one of its employes, Nathaniel B. Stimpson. Known affectionately as "Buzz" by all members, he is serving his 47th year as lodge Steward. Employed as "extra help" for a dance the lodge held in 1911, Mr. Stimpson stayed on and has discharged his duties faithfully ever since.

*Myrtle Beach, S. C., Lodge held a successful Ladies and Bingo Night recently, emceed by Carlisle Taylor. Prizes were won by Frank Hughes, Ira Jennings, E. Olson, Jerry Blount and John French.*

*E.R. John B. White and his fellow Pampa, Tex., Elks welcomed State Pres. Chas C. Bowie on his official visit recently. Mr. Bowie, a Grand Lodge Youth Activities Committeeman, was accompanied by State Secy. H. S. Rubenstein and Trustee Wm. J. B. Frazier of the Texas Elks' Crippled Children's Hospital.*

*We have just learned of the passing of E. D. McArthur, a long-time member of Coos Bay, Ore., Lodge who was mentioned in our Old Timers feature last month. Mr. McArthur passed away at the age of 88 on March 20th, just 18 days after his wife's death.*

Recent initiates of South Orange, N. J., Lodge were Lloyd and Herbert Golby, stepsons of Elk Allie Frank. Another brother, Willard, and their uncle, Roy Cohen, are also members of the lodge.



These men were initiated into Iron River, Mich., Lodge in honor of State Pres. Robert A. Burns.



Baton Rouge, La., Elk officials, seated, initiated a class of ten candidates, also pictured, as a tribute to State Pres. Clarence LaCroix who appears third from left, background.



Buckhead, Ga., Lodge officers are pictured with the class they initiated in honor of Grand Exalted Ruler Fred L. Bohn. Seated, center foreground, is A. J. Bohn, cousin of the Order's leader and a long-time member of Buckhead Lodge.



Officials of Norwalk, Conn., Lodge, pictured with the class they initiated recently in the presence of D.D. W. G. Harold, P.D.D. C. R. Mitchell and State Rep. L. J. Padula.

**Nashville, Tenn., Lodge  
Honors Edward W. McCabe**

Presentation of an Honorary Life Membership to Trustee Edward W. McCabe highlighted the observance of Past Exalted Rulers' Night at the home of Nashville Lodge No. 72.

The award was presented by Pres., Henry Beaudoin of the Tennessee Elks Assn., after the rare honor was voted by the Nashville Elks in recognition of Mr. McCabe's long and extensive service to Elkdom, as well as his many other civic endeavors. A P.E.R. of the lodge, Mr. McCabe was instrumental in organizing the Tennessee Elks Assn. 15 years ago, and later served as its President. He has been District Deputy and has been a Trustee of his lodge since 1945. At this time he is Chairman of the Grand Lodge Ritualistic Committee, an office he has held since 1954.

More than 20 P.E.R.'s were honored at a dinner preceding the lodge session during which they served as the Ritualistic Team which initiated a class of 19 candidates in honor of Mr. Beaudoin.

P.D.D. Earl Broden, State Chairman of the Elks National Foundation Committee, presented participating memberships in the Foundation to E.R. Charles Petty and Est. Loyal Knight Harry Lester, denoting a \$100 contribution to the Foundation by Elks Morris Steiner and Abe Olshine both of whom have contributed several Foundation Certificates to other Nashville Elks. Demonstrating his lodge's participation in the Foundation campaign, E.R. Petty presented to Mr. Beaudoin a \$250 check, the final payment on its \$1,000 contribution for the year.

**Baltimore, Md., E.R. McCardell  
Honored at Dinner**

A crowd of 500 persons attended the brilliant testimonial dinner given by Baltimore Lodge No. 7 for E.R. J. Neil McCardell. The event was held in the beautifully decorated main ballrooms of the lodge home, with Past Grand Exalted Ruler Dr. Robert South Barrett as a special guest.

Joseph L. Manning was General Chairman of the Dinner Committee, assisted by George W. Krill and Ralph De Chiaro. Program Trustees Chairman was Nicholas M. Pirone, Sr. Others who contributed toward making the affair the success it was included Ticket Committee Chairman Patrick F. O'Malley; Menu Committee Chairman Martin J. Welsh, Jr., Decoration Committee Chairman P.E.R. C. A. Hook and Reception Committee Chairman Charles A. Kreachman. All were assisted by groups of competent members.

**Rock Hill, S. C., Elks  
Make Hit With Orphans**

"It was a swell party," children of the Church Home in York told their hosts from Rock Hill Lodge No. 1318 following the banquet, movie and entertainment program the Elks had provided for them. A chicken dinner preceded the showing



Edward W. McCabe, P.E.R. and Trustee of Nashville, Tenn., Lodge and Chairman of the Grand Lodge Ritualistic Committee, left, receives an Honorary Life Membership card from State Pres. Henry W. Beaudoin as Nashville E.R. Charles Petty looks on. This presentation, highlighting the lodge's P.E.R.'s Night program, was made in recognition of Mr. McCabe's long-time efforts in behalf of the Order and his many civic activities.

On P.E.R.'s and Old Timers Night at Hornell, N. Y., Lodge, an 89th Anniversary Class was initiated. Among the candidates were the sons of two P.E.R.'s and the son of the lodge's current E.R. Seated, left to right, with their fathers standing behind them are John G. Geary and his father, William; Robert E. Alger, and his father Everett C., and Peter M. Jordan and his father, E.R. William M. Jordan.



Children and instructors of the Washington School in Medford, Mass., were guests of the Elks of that community at their annual "Good Neighbor Party". The Elks, whose home is located next door to the school, gave the party as a gesture of friendship and cooperation to impress the "good neighbor policy" on the youngsters. P.E.R. Edgar C. Babcock was Chairman of the Committee.

of a movie on the local high school band's trip to Miami and the Orange Bowl game, narrated by Bob Bryant.

Highlight of the evening were songs by television star Fred Kirby who had the children join him in several specialty numbers. He told the youngsters he'd try to have them appear with him on TV; in

the meantime he posed with them for a picture he will show on his program.

Est. Lead. Knight Lem Holroyd presided, introducing special guests, and presented a gift to Mrs. F. D. MacLean who, with her husband, has resigned as co-directors of the Home after 17 years.

(Lodge News continued on page 30)

Day or Night  
**ENJOY  
 SOUNDER  
 SLEEP**  
 with the Original  
**SLEEP SHADE**



Try this drugless way to sound, refreshing sleep... the original sleep eye shade that shuts out light, improves rest. Scientific design lets eyes blink. Patented soft, adjustable tape and twin elastics hold Sleep Shade comfortably in place without pull or pressure. Weighs 1/2 oz. Over a million and a half sold. Complete satisfaction guaranteed or full refund. Black sateen Sleep Shade **only \$1.25** at Drug or Dep't. Stores. Or order direct from

**SLEEP SHADE COMPANY**  
 828 Mission St., P.O. Box 968, San Francisco, Calif  
 (Postage prepaid if payment sent with order)

**HUNTERS!**  
**SPECIAL SPRING  
 GUN SALE**

**SPECIAL \$19.95**  
**ENFIELD RIFLES**

Cost British about \$85. Ours is the lowest price ever placed on a modern first quality military rifle! This is the British Lee Enfield Army rifle, used today by British troops throughout the Empire. High velocity, powerful .303 cal. ammo is ideal for all N. American big game (sold everywhere in U.S.). Adjustable sights, 10-shot bolt action, bbl. 25", wt. 8 1/2 lbs. Bears British ordnance and royal proofhouse marks. Guar. good bore and exterior. We are also offering a few in Very Good cond. at \$23.50 and a very few specially selected for exterior finish at \$28.75. FREE—with all guns: official sling and 20 rds. ammo. OFFICIAL BAYONET, \$1.95. TARGET AMMO, \$7.50 per 100 rds. HUNTING AMMO, \$2.95 per 20 rds. PACHMAYR LOSING SCOPE MOUNT for this rifle, \$30.00.

TO ORDER: Send check, cash or money order, 1/4 deposit for C.O.D. Shipped Exp. Coll., F.O.B. Pasadena, Calif. resid. add 4% state tax. 10-day money back guar.

CANADIANS: Order (without red tape) rifle Sped. from G.K. Harper, 16 Bayswater, Ottawa.

**GOLDEN STATE ARMS CORP.**  
 386 W. Green St., Pasadena 40, Calif.

Regular Price of a Slide  
 Rule \$4 and Up

**92c** and this coupon  
 Add 8c Postage

**SLIDE RULE**

If you can use a pencil you can use this Slide Rule

For students, accountants, salesmen, farmers, everybody. Invaluable for Armed Forces. Man's most useful tool. Easy to calculate instantly, accurately. Multiplying, proportions, division, roots, etc. "High Vision" Clear View Slide. Full 10" Rule. A, B, C, D, C1 and K Scales. Limit 3 rules per coupon. Money back guarantee.

**FREE** 28-page Instruction Book on how to get correct answers instantly without pencil or paper.

**LARCH**  
 118 EAST 28, DEPT. 12A NEW YORK 16



**Stop Dog and Cat Damage—\$1**

**DOG WICKS** are the perfect solution for repelling pets. One sniff and away they'll run! Hang this chemical Wick on shrub or branch and rest easy for the whole season. Rain won't wash away repellent scent. Safe, harmless to animals. Use inside or out—protects lawns, garbage pails, flowers, furniture. Trains your pets and neighbor's dogs. Guaranteed to do the job or your money back! Pack of 20 for \$1, postage paid. Order **DOG WICKS** direct by mail from **Sunset House**, 887 Sunset Building, Hollywood 46, California.

# Elks Family



**HIGH FLYIN' HELICOPTER.** Just push a button to launch this new Remote Control Bell Experimental Helicopter on its flight. With its two rotary blades spinning on each wing tip, it'll take off, go forward, then reverse—and a light shines brightly in the cockpit while it's flying. \$2.98 ppd. (Batteries not included.) Medford Products, Dept. E, Box 39, Bethpage, N. Y.



**E-Z LEMON.** Just a squeeze gives you a squirt of real juice of California lemons for cooking, cocktails, etc. This handy gadget is made of plastic, looks and feels just like a fresh lemon. Needs no refrigeration, keeps 12 to 18 months after opened. Keep one at the bar, another for table service. Contains 2 fl. oz. Two for \$1.00 ppd. Taylor Gifts, Dept. E, Wayne, Pa.



**YOU'LL MAKE A NAME** for yourself as a person of taste when you select these smartly styled Name Pins for gifts. They're attractive, useful and so flattering to the recipient. Each is solid brass, hand cut, hand buffed, brilliantly gold plated and fitted with a nickel silver safety lock clasp. \$2.00 each ppd. Custom Craft, Box 398, Dept. E, Westbrook, Conn.



**STOW YOUR GEAR** instead of strewing it all over the car. New Scotch-Plaid Car-Tote has three roomy compartments for toys, books, maps, picnic supplies, etc. It's a gem for salesmen's papers. Sturdy steel holder fits over front or back of seat. It's washable and waterproof. Red/green plaid. \$5.95 plus 25¢ postage. Laurie & Co., Dept. E-5, 507 5th Ave., New York 17.

Merchandise shown on these pages can be ordered direct from the companies listed. Enclose a check or money order.

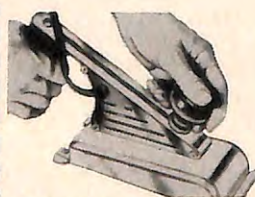

**ELECTRIC  
 PAINT  
 PEELER**  
 ONLY  
**\$11.98**  
 postpaid

Removes paint twice as fast as any other safe method

This is "paint-up" time, and POWERMET Electric Paint Peeler is your safest, fastest, easiest way to do any paint removing job. Heavy-duty POWERMET zips through up to 12 layers of old paint like a hot knife through butter. Removes paint, enamel, varnish, shellac as fast as 3 1/2 square feet per minute, leaving bare wood surface smooth and clean. Eliminates tiring sanding, cutting, scraping, dangerous burning and chemicals. POWERMET can be plugged into any 110-120 volt AC or 600 watt DC outlet. Heats to 1200 degrees in minutes. Enclosed heating unit softens paint and front-end scraper blade peels it off. Works on all regular, or irregular, interior or exterior woodwork including cupboards, doors, furniture, boats, etc. Heating surface measure 3" x 7". POWERMET comes complete, ready-to-use, with 2 foot U. L. Approved heater cord. All parts GUARANTEED and replaceable. Prompt delivery. ONLY \$11.98 postpaid. If C. O. D. plus charges.

**MERIDIAN CO.**, 366 Madison Ave., Dept. P-35, New York 17

**GROW IN  
 YOUR  
 YARD!**

MADE OF  
 EVERLASTING  
 ALUMINUM



**PYRAMID STRAWBERRY GARDEN**

Adds interest and beauty to your garden. Produces a bigger, better crop. 5 ft. size just right for 50 plants. **Only \$7.95 ppd.**

**SPECIAL!** 5 ft. aluminum garden with 50 Superfection everbearing strawberry plants. **Complete... Only \$9.95 ppd.**

ORDER FROM THIS AD. SEND CHECK OR MONEY ORDER!

**MINNETONKA NURSERIES**

Dept. E5

Excelsior, Minnesota



# Shopper



**PICTURE YOUR LOVED ONES** on this attractive Tie Slide and Cuff Links. Make this Photo Jewelry yourself from kits that include frames and magnifying lenses. All you do is insert snapshot into gold-plated frame, cover with magnifying lens and bend edges of frame over lens. Tie Slide, \$1.00; Cuff Links, \$1.50 ppd. Baby Shoe Studio, Dept. E, Richmondville, N. Y.



**HERE'S A SWITCH** for Dad. He can change belts just by snapping them off and on this Monogrammed Buckle. 1" polished leather belt comes in black or brown with gold or silver finished buckle for \$1.95. Two belts with one buckle are \$2.95; 4-way combination of 2 buckles and 2 belts, \$3.75. Add 20¢ postage. Ruth Brawer, Box 4035, Dept. EKF, Tucson, Ariz.



**NO SHOE FITTING PROBLEMS** here. Women who wear so-called "difficult" sizes especially will bless these hand-laced Mocs that come in a range from 3 to 13, widths AAAAA to EEE. And all sizes will love their soft leather, buoyant crepe soles, and smart styling. In white, red, taffy tan or smoke. \$5.95 plus 50¢ postage. Moccasin-Craft, 65-EF Mulberry, Lynn, Mass.



**TELL-TALE TIES** of pure silk picture your profession or hobby in interesting hand-painted motifs: Elk, Doctor, Lawyer, Golfer, Stock Broker, Fisherman, Engineer. In brown, maroon, dark or light gray, \$5 each ppd. with motif or 3-letter monogram. Add 50¢ for both motif and monogram. Tie-Of-The-Month Club, Dept. E, 520-5th Ave., New York 17, N. Y.

Except for personalized items, there is guaranteed refund on all merchandise returned in good condition within 7 days.



## SCARE BIRDS AWAY! — \$1

'SCRAM-OWLS' frighten birds and keep 'em away from your fruit trees, gardens, lawns. Protects your clothes-lines, window ledges, patio, cars and outdoor furniture. Bright, colorful metallic Owls repel birds without harming them. Decorative, cute. Each is 3 1/2" x 5". Set of 8 for only \$1, postage paid. **Guaranteed to do the job or your money back!** Order SCRAM-OWLS SET direct by mail from Sunset House, 880 Sunset Bldg., Hollywood 46, California.



## GENUINE DIAMONDS UP TO 50% OFF

Buy diamonds and diamond jewelry half-priced from Kaskel's, America's diamond specialist. Every diamond is re-set in a luxurious new mounting . . . graded according to nationally accepted standard . . . and bonded to this effect. For over 70 years, we've served over 1,000,000 satisfied customers. CASH OR CREDIT. 10 DAY UNCONDITIONAL MONEY-BACK GUARANTEE. Send FREE CATALOG and Advice about DIAMONDS without obligation.

**KASKEL'S** 41 West 57th St. N. Y. 19, N. Y. Dept. 767-E

## YOUR OLD FUR COAT INTO NEW CAPE, STOLE!



STYLE #55  
**\$22.95** COMPLETE

ORDER BY MAIL  
2-3 week delivery

Send for FREE Style Book

I. R. Fox, fur remodeling specialist, re-styles your old, worn fur coat regardless of condition into glamorous 1957 cape or stole. Special price, \$22.95 complete! This special price includes cleaning, glazing, repairing, lusterizing to new sheen, remodel completely, plus a lovely NEW LINING and INTERLINING & Monogram at no extra cost. The thrilling result—a luxuriously beautiful cape, stole or jacket. **SEND NO MONEY!**

Just wrap up your old fur coat, mail it to us now. Send your dress size and height on postcard. Pay postman \$22.95 plus postage when new cape arrives. Or send for FREE Style Book now! Many different styles to choose from. Write:

I. R. FOX, 146 W. 29th ST., DEPT. K-30, N. Y. C. 1, N. Y.



## Now—PEARL GUARD RINGS—too.

Mix & Match them. Sterling Silver or Gold plate on Sterling, set all around with tiny turquoise blue stones or simulated Pearls, Diamonds, Rubies, Sapphires or Emeralds. Special Prices for Suggested Combinations  
Plain (no gems) . . . \$1.50 ea. Gem Bands . . . \$2.95  
2 Gem Bands . . . \$5. 2 Plain and 1 Gem . . . \$5.00  
2 Gem and 1 Plain . . . \$6.50 3 Gems . . . \$7.50  
Send ring size or measure with string. Satisf. guarant.  
Send Cash, Check or m.o. For COD's send \$2 deposit.

**OLD PUEBLO TRADERS,** Box 4035, Tucson, Arizona

## For Those Who Do Not Want GREY HAIR

Now **Top Secret's** amazing scientific formula gives a natural looking color to faded or grey hair . . . makes you look years younger! **Top Secret** does not streak or injure hair, does not wash out.



"I noticed results after just a few applications," says Jan Garber, Idol of the Airlines. "Top Secret is easy to use—doesn't stain hands or scalp. **Top Secret** is the only hair dressing I use."

Time-proven **Top Secret** has been used by famous personalities for years.

Send \$5 (Fed. Tax incl.) for 6 oz. plastic container, convenient for traveling, too. Ppd. No COD's, please. Money back if not delighted with results of first bottle! **Albin of California,** Room 54, 1401-91 W. 8th St., Los Angeles 17, Calif.

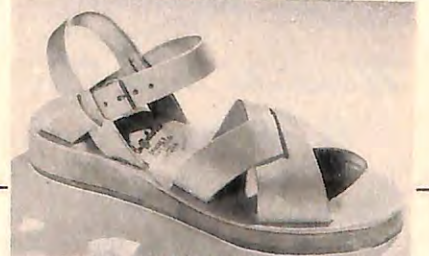

The **Buffaloha** "CAVANA" handmade of leather imported from INDIA

If you like to loaf, you'll like the easy, airy comfort of the "Cavana." These cork-platform sandals are made entirely by hand of long-wearing natural-color Water Buffalo leather. For year-round wear, sizes 3-13. Brochure on request. Money Back Guarantee.

**Bloom's** 311 Sixth Ave., Dept. E-57 New York 14, N. Y. "Down In the Village" over 60 yrs.

# 3 Colored Spectacular SPACE KITE

- It's 3 Dimensional
- Made of tear proof acetate cloth
- 28 inches high



FUN For Young & Old

See your Space Kite fly high in the sky. Exciting and thrilling. A wonderful gift. Easy to fly because of its 3 dimensional construction. Takes off like an airplane for sure, speedy flight.

**\$1.98**

## FLY ANYTIME—ANY WEATHER

You'll gasp with wonderment as you see "her" in the sky. The 3 brilliant colors add to its magnificence as it flies anywhere regardless of weather. It's practically indestructible. Made of high quality acetate cloth that is sewed and reinforced. It's 28 inches high. Think of it! Over 2 feet tall. Take it along anywhere—the country, beach, etc. Packed in handy, compact, sturdy tube with a free plastic carrying case. Has won first prizes. Has flown over large monuments. Used for weather research. It's precision made to give you years of flying fun. Your Space Kite is a controllable, 3 dimensional aeronautic kite that climbs, zooms, glides. A terrific flyer. A conversational creation.

## 42" x 29" 8 COLOR HAMMOND WEATHER MAP FREE

10 DAYS FREE TRIAL  
Space Kite fans can become weather forecasters in a jiffy with this 8 colored weather map. Shows 16 actual pictures of weather fronts including Thunderstorms, Tornadoes, Hurricanes, Warm Fronts, Occluded Fronts and their relationship to actual weather conditions, no matter if it is raining, snowing or sunny. You learn the wind scale and there is a station model to help you pin point every weather condition known to meteorologists. This weather map is included FREE with your Space Kite.

## HOW TO ORDER

Your Space Kite is sent on absolute guarantee of money back if not delighted after 10 days trial. Price is \$1.98 postpaid plus 25c for handling and packing. Or sent COD plus COD fees. (250-foot balls of special kite cord available at 50c each.) There is also a Deluxe Space Kite which is 35 inches high and comes with 250-foot ball of kite cord. Price for Deluxe Kite is \$2.95 plus 25c for handling and packing. Both models come packed in a tube with Free plastic carrying case. Your free weather map is included with either offer. Even if you decide to return your Space Kite, which we know you won't, you keep the weather map because it is FREE with this offer. Rush coupon today!

**TERRY ELLIOTT CO., DEPT. SK-100**  
135 East 44th St., New York 17, N.Y.

Send Space Kite checked below or your 10 day money back guarantee. Also include my free 8 colored 42" x 29" weather map.

Send 28" Space Kite. \$2.23 enclosed in full payment.

Send 28" Space Kite C.O.D. I will pay postman.

Send 35" Deluxe Space Kite. Enclosed find \$3.20 in full payment.

Send 35" Deluxe Space Kite C.O.D. I will pay postman.

Send . . . balls of 250-foot kite cord at 50c each. (I have included this amount with the above order.)

NAME . . . . .

ADDRESS . . . . .



No. 13

## Now—A New Pin of Distinction

Added to the line of handsome Elks insignia pins is the newly created PAST DISTRICT DEPUTY lapel emblem. What is more fitting than a pin that symbolizes one of the highest appointive offices in the Order? It's a jewel of an emblem and one that the owner will forever treasure. Brilliantly enameled red, white, and blue insignia on 10kt gold base. Please order by number. No. 13 is \$13.00. 13A set with 5-pt blue sapphire \$17.00. 13B with one 5-pt diamond \$46.00.

Write The Elks Magazine  
386 Fourth Avenue, New York 16, New York

## FORGED IRON BRACKETS

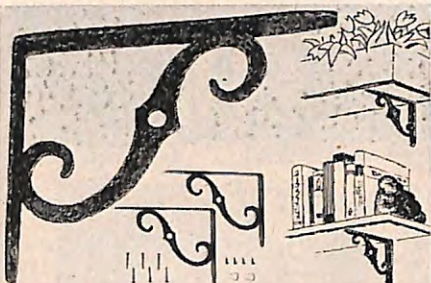

At last, an attractive shelf bracket artistically designed in authentic ornamental forged iron. Hundreds of uses inside and outside. Beautiful shelves can be yours in minutes—ideal for window flower boxes or planters. Many practical ideas included with each pair. Free set of clips for glass shelves. Order now, each set complete with all forged square-head screws—Colonial Black finish. Size 6" x 4 1/2", only \$2.98 the pair. 8" x 6", only \$3.49 the pair, postpaid. FREE CATALOG. Satisfaction guaranteed or money back. Order from:

**MARYLAND PRODUCTS COMPANY**  
Dept. E-2, 4929 Del Ray Ave., Bethesda 14, Maryland

## E-Z FLOW

Automatic INSTANT COFFEE DISPENSER  
\$1.00 ea. ppd.



2 for \$1.75  
A press of the button releases one measured level teaspoonful or as little as a few grains of instant coffee. Wonderful for breakfast or dinner coffee because it always measures just the right amount. Use also for sugar, salt or soap powder. Sanitary, economical, lightweight.  
Pa. Residents Add 3% Sales Tax  
**FREE GIFT CATALOG TAYLOR GIFTS**  
Wayne 4, Penna.



## U.S. ARMY COMBAT .45 AUTOMATICS

The famous Colt .45 is recommended by experts as the most effective and reliable sidearm in use today. The ideal weapon for home protection, target shooting, and as a sidearm for hunting trips. Designed and developed by Colt's Mfg. Co. and adopted as the official sidearm of the U.S. armed forces because of its tremendous killing power and deadly accuracy.  
Costs \$74.50 new today—Bore guaranteed excellent. The outside are perfect except for a few signs of holster wear.  
**\$3995**  
10-DAY MONEY BACK GUARANTEE  
Extra Magazines, \$1.50 each. SPECIAL: 45 ammo, 50 rds., \$2.50.  
TO ORDER: Send check, cash or M.O. \$10 dep. for C.O.D. Shipped RR Ex. collect FOB Pasadena. Enclose signed statement "am not alien, never convicted violent crime, not under indictment or justice, am 21 or over." Mass., Mo., Mich., N.Y., N.J., N.C., R.I., Omaha, New Orleans require permits. Get from police station, enclose with order. Calif. resid. order through local dealer.

**GOLDEN STATE ARMS CORP.**  
386 W. Green St., Pasadena 45, Calif.



## REVERSIBLE AUTO SEAT COVERS

Made of FLEXTON plastic. Choice of: SNAKE-ZEBRA DESIGN or LEOPARD-COWHIDE DESIGN

Each Only **\$2.98**  
ORDER FROM MFR. AND SAVE  
Colorful SNAKE AND ZEBRA DESIGN AND LEOPARD-COWHIDE DESIGN. Can Be Used On Either Side. Water And Stainproof. Tailored With Side Grip Panels For Tight Fit. Sewn With NYLON Thread For Long Wear. Simple To Install. Dress Up Your Car With These Colorful Expensive Looking Covers!

**10 DAY MONEY BACK GUARANTEE**

Choice Of SPLIT Or SOLID Front Seat Only \$2.98. Complete Set for Both Front & REAR Only \$5.00. Specify Design Wanted, Make Of Car And Seat Style. Enclose Payment And Save Postage Or Sent COD.  
**MARDO SALES CORP.** Dept. CR-7  
480 Lexington Ave., New York 17 N. Y.

# Elks Family Shopper



**FOLDING CUPS** of durable, sanitary plastic are just right for stowing in the glove compartment of your car; for school lunches (there's a waterproof change compartment in the cover); for picnics or camping. Assorted colors, first name stamped in gold on the lid. Two cups, \$1.00; Box of 4, \$1.75 ppd. Handy Gifts, Room #9, Jasperson Bldg., Culver City, Calif.



**STEAM IRON CLEANER** removes scale and iron deposits that keep your steam iron from operating at top efficiency. A small amount of concentrate quickly dissolves deposits so your iron will heat up faster and more evenly. Use it too on kettles, vaporizers or any non-porous water heating utensil. \$1.00 ppd. Elron, Inc., 225 W. Erie St., Chicago 10, Ill.



**IT'S EASY TO FIT** linoleum and other floorings around tricky obstructions with the Contour Scriber. It adjusts to draw circles or scrolls from 1" to 25" in diameter so that you can match perfectly irregular outlines of pipes, cabinets, door sills, etc. Scriber is of sturdy metal construction. \$1.49 ppd. Meridian Products Co., 366 Madison Ave., Dept. E, New York 17, N. Y.

Save these Elks Family Shopper pages. They make a handy catalog of gift items for all occasions.

# Elks Family Shopper



**GRACIOUS LIVING** isn't always costly. Sometimes it's no more than the lovely, nostalgic scent of lavender sprayed on your sheets, cases and towels, or in closets and chest drawers. This 6-oz. pressure can of Lavender Mist sprays at a touch, lasts and lasts. \$1.50 ppd. Carol Beatty, 274 Beatty Bldg., 7410 Santa Monica Blvd., Los Angeles 46, Calif.

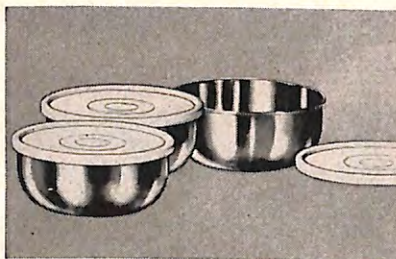

**STAINLESS STEEL** makes a Food Saver. Set you use three ways: to store, warm and serve food. For a busy housewife, this time and dish-washing saver is a pure delight. Each bowl holds 1/2 quart and has a snap-on plastic lid that really locks in flavor, locks out other odors. Set of 3, \$1.98 ppd. Homemaker's Service, Dept. E, 4450 N. Ravenswood Ave., Chicago 40, Ill.



**SELF-STARTING SIPHON PUMP.** Just a squeeze of the bulb on this pump starts fast siphon flow without dangerous and unpleasant sucking. You can transfer gas from car tank, empty a clogged sink, or drain small flooded areas. Plastic valves are rust-and-acid proof. Over 6' long. \$3.00 ppd. Sportsman's Post, Dept. ES, 366 Madison Ave., New York 17, N. Y.

Please mention The Elks Magazine when writing to our Elks Family Shopper Advertisers.



View of one of the lawns surrounding the lovely \$200,000.00 home of Spurgeon Pickering, owner of Mondo Grass and Nursery Company, on the beautiful beach of the Gulf of Mexico; the entire seven lawns, sidewalk shoulders and neutral grounds are planted solidly in Mondo "Grass," truly one of the most attractive show places of the South.

## NOW IS GOOD TIME TO PLANT BLUE-GREEN MONDO "GRASS"

Trade Mark Registration applied for U. S. Patent Office

**REQUIRES NO MOWING—MAKES  
WORLD'S MOST BEAUTIFUL LAWN**

Our Blue-Green Mondo "Grass" is described by the U. S. Department of Agriculture as "Ophiopogon Japonicus (formerly called Mondo Japonicus)", is native to Northern China and should withstand severe degree of freezing; drought tolerant, evergreen, commonly called Mondo "Grass."

It is a "grass" relative to the lily with paper thin blade 1/16" wide. This sod-forming EVERGREEN, low-growing oriental genus is currently used by many owners of distinctive homes in America for lawn grass. Now we can offer this exclusive Blue-Green Mondo "Grass" at popular prices.

SO HARDY IT CAN BE PLANTED ANYTIME, it is recommended for beautiful lawns where mowing is not desired. Blue-Green Mondo "Grass" retains its color the year-round; thrives in shade or sun; extremely hardy, rarely requires watering; fantastically beautiful, drooping low to the ground in weeping style year after year. **REQUIRES NO MOWING AND SHOULD NEVER BE MOWED.**

Guaranteed to withstand severe freezing or money refunded. Ideal for heavy shaded areas, dry or wet. **FREE** folder of testimonials and many photos of Mondo "Grass" lawns sent on request.

Mondo is resistant to diseases; insects and animals will not feed on it. Stops erosion; grows compactly, crowding out other grass and weeds; multiplies rapidly, approximately 100 times (10,000%) first year. Enhances property value. So sensational we expect to revolutionize lawn-making. For good coverage first year plant 4" to 12" apart. Numerous rooted blades to sprig.

Planting and culture instructions with each order. Shipped now or when desired. Remittance with order. Shipped prepaid. **MONEY-BACK GUARANTEE:** if not completely delighted you may return at once for refund. Open account to A-1 rated firms buying 1,000 sprigs or more, FOB, Biloxi. Distributors wanted everywhere.

### ORDER TODAY . . . YOU CAN'T LOSE!

Sprigs packed in damp moss. Guaranteed to grow or we will replace.	
25 Sprigs..\$2.98	1,000 Sprigs \$79.00
50 Sprigs.. 5.00	5,000 Sprigs
100 Sprigs.. 9.00	or more
500 Sprigs..40.00	per 1,000..50.00

Mondo Grass & Nursery Co., Dept. E, Biloxi, Miss.  
Please send prepaid ..... Sprigs of Mondo "Grass", for which I enclose \$.....  
Name.....  
Address.....  
City..... State.....



PERSONALIZED, DATED CUFF LINKS. Star that big day, for him or her to always remember. Just give us the month, the date, his or her initials. (Please print.) Hand engraved in gleaming, tarnish-proof golden finish, they're beauties! (3/4 inch square.) Exclusively ours, and **ONLY 6-98** postpaid, beautifully gift boxed. (9.98 if birthstone marking date is desired.) **FATHER'S DAY DELIVERY GUARANTEED.** Send orders to: **THE NASSAU CO., Dept. E, 200 West 34th St., New York 1, N. Y.**

### 1000 Name & Address Labels \$1.00



Your name and address beautifully printed on 1000 fine quality gummed labels. **FREE PLASTIC BOX.** Use them on stationery, checks, books, greeting cards, records, etc. Printed on finest quality gummed paper. Six orders for \$5. **THIS IS A SPECIAL OFFER.** A sensational bargain. Ideal for gifts. Makes a wonderful, useful present. Satisfaction guaranteed or your money back. **HANDY LABELS, 506 Jasperson Building, Culver City 1, California.**

### FELLMAN LTD.



### For The Fortunate Few Who Appreciate The Very New!

Everything about this shoe is new... except its genuine moccasin comfort! The meaty leather is superbly mellowed, and hand-finished to an antique *burnt ivory* that grows richer with age! Hand-moulded by Taylor's Down-Maine craftsmen—and embellished with genuine hand-forged buckles, these shoes are an adventure in fashion and an experience in unequalled comfort!

Sizes 6 to 12, widths AA to E **\$1895**

**ORDER BY MAIL—give exact shoe size, satisfaction guaranteed. Please add 35¢ for shipping.**  
**FELLMAN LTD., 49 W. 43 N.Y. 36, Dept. ES**  
also 6 E. 46 St. NYC and Newark, N.J.



### FLATWARE CADDY

This specially designed plastic tray stores up to 100 pieces of silverware. Built-in separators and compartments hold 12 place settings in neat order. 12" x 10 1/2" x 2 1/4" tray fits all drawers, making old fashioned bulky chests unnecessary. Pacific Silver Cloth Liner fits tray exactly, prevents tarnish. Satisfaction guaranteed. Order #K230.

Complete with liner \$3.98 postpaid  
**DOWN & CO., Dept. 3387R, Evanston, Illinois**

# 41 Surplus Twist \$2 DRILLS



For hand or electric drills. Brand new, genuine hardened carbon tool steel drills from 1/16" through 1/4". Each drill designed and tempered to give 1800 drillings through steel, aluminum, iron, wood, plastic. Sells in the stores for up to \$6. **\$2 complete set postpaid.**

**MONEY BACK IF YOU DON'T AGREE THIS IS THE BEST TOOL VALUE EVER!**

Send Check, Cash, Money Order, WE PAY POSTAGE . . . If C. O. D. You Pay Postage

**SCOTT-MITCHELL HOUSE, INC.**  
DEPT. 5105, 611 BROADWAY, N. Y. 12, N. Y.



## NO MORE SMELLY REFUSE PAILS

No Flies or Ants

If you have a garbage pail that attracts flies, ants—dogs, cats, rats—or maggots indoors or out, you should learn about SAN-A-LIZER . . . a harmless cake that fastens inside the lid of your garbage pail without tools in seconds, SAN-A-LIZER keeps pests away and completely deodorizes! Send \$1.10 for a year's supply (4 cakes). It's noninjurious to children and pets. Postpaid. Money-back guarantee. Dealer inquiries invited.

**SAN-A-LIZER CORP.**  
Dept. E 3047 Rosslyn St., Los Angeles 65, Calif.

# \$4,000.00 FOR 5c OLD MONEY WANTED

\$4,000.00 for 1913 Liberty Head Nickel. Uncirculated Dollars 1804 to 1839, 1893-S, 1895-P, 1903-O pay \$100.00—\$5,000.00. Certain dates—Small Cents before 1915—\$325.00; Dimes before 1917—\$2,000.00; Quarters before 1924—\$1,000.00; Half Dollars before 1905—\$1,000.00; 2c pieces—\$70.00; 3c pieces—\$90.00; Half-dimes—\$500.00. Hundreds of others worth \$10.00—\$1,000.00. Canadian Coins—1921—5c Silver, \$50.00. 1889—Dimes—\$25.00. 1875 Quarters—\$50.00. 1921—50c—\$200.00. Wanted—20c Pieces, Gold Coins, Paper Money, etc. Our Large Illustrated Guarantee Buying—Selling Catalogue, Giving Complete Alcoin Information—Send \$1.00. Purchase Catalogue before sending coins. Worthycoin Corporation, Leaders Numismatic Quotations K-693-C, Boston 8, Massachusetts.

# FREE MATERNITY STYLE CATALOG



Save money on Maternity Styles. Shop from CRAWFORD'S World Famous Maternity Catalog. Hundreds of economy-priced Maternity dresses, suits, separates, lingerie, girdles, bras, sportswear. **FREE GIFT CHECK!** CRAWFORD'S, World's Largest Maternity Style Center, will mail you a FREE Bone-Fide Check to spend on your first order. Write for FREE Catalog (mailed in plain envelope) and gift check.

**Crawford's**  
Dept. 104 8015 Wornall, Kansas City 14, Mo.

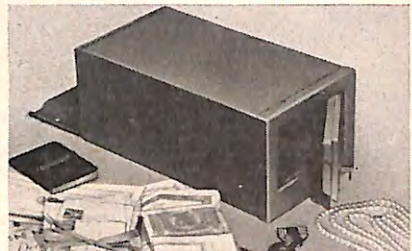

**SAFE DEPOSIT VAULT** keeps private papers and valuables safe . . . at a fraction of the cost of a regular home safe. You can install it easily anywhere—on a closet shelf, desk, floor, etc. The vault locks into place over the base so it cannot be removed until unlocked with the combination. \$19.95 plus 90¢ shpg. chgs. Executive Prod., Dept. SD-37, Box 61, Baldwin, N. Y.

# READ THESE FACTS BEFORE YOU ORDER YOUR ZOYSIA GRASS



- U. S. DEPT. OF AGRICULTURE PERFECTS "THE WORLD'S MOST PERFECT LAWN GRASS!" Approved by U. S. Golf Assn.
- STAYS GREEN EVEN THROUGH DROUGHT When ordinary grass burns brown
- CHOKES OUT WEEDS, CRABGRASS, OLD GRASS
- 2/3 LESS MOWING—2/3 LESS CARE
- NO WATER PROBLEMS

**GUARANTEED** To Grow In Any Soil—Even Beaches!  
A True Perennial . . . Never Needs Re-Seeding. Ends Seed Expense!

Has survived 3 months in desert without water



**Just Plug It In And Watch It Spread Into A Beautiful, Velvety Lawn!**

1. **NO WASTE, NO SOD TO CUT, NO SEED FAILURE.** Comes in fresh, green plugs of living grass that assure rapid, sure growth.
2. **Just set pre-cut plugs into holes in ground, like a cork in a bottle.** (Plant 1 foot apart, checkerboard style. Easy planting instructions with each order.)
3. **Each soil-enriched plug takes root, spreads to cover planted area with thick, beautiful turf.**
4. **Amazing root system** grows so deep (2-3 feet down) your lawn finds and retains its own supply of underground water. No more ugly brown or bare spots in your lawn—EVER!

**Takes playground punishment!** Grows in soils where other grass fails. Ideal for paths, children's play areas. Takes heavy wear—springs back unharmed. Amazoy is planted in Pimlico Race Course. Laurel Racetrack says, "Meyer Z-52 . . . the answer to our turf problems!"

**Avoid risk of lost labor and disappointment. Order Amazoy Meyer Z-52 Zoysia grass today. Any plug failing to grow replaced free!**

**Order Now From WORLD'S LARGEST GROWERS And Save! NEW LOW PRICES**

100 Large Pre-Cut PLUGS.....	\$9.98
100 Large Pre-Cut PLUGS & PLUGGER.....	\$11.98
300 Large Pre-Cut PLUGS & PLUGGER.....	\$24.98
600 PLUGS & PLUGGER.....	\$44.98

Perfected by U.S. GOV'T. APPROVED By U.S. Golf Assn.



**ZOYSIA FARMS**  
602 N. Howard St., Balto., Md.  
333 N. Michigan Ave., Chicago 1, Ill.

Genuine AMAZOY is the revolutionary lawn grass that produces a weed-free, carefree lawn. So deep-rooted it goes weeks and stays beautiful without rain or watering, whether due to water bans or because you're away. Needs 2/3 less mowing, 2/3 less care than seed-type grasses. Grows so thick it drives out weeds, crabgrass, old grass, etc. Even when other lawns burn out or turn patchy this summer, yours will be lush green, beautiful—the pride of your neighborhood.

**AVOID DOUBLE EXPENSE AMAZOY COSTS YOU LESS**

AMAZOY costs you less because it ends seed expense and waste forever—NEVER needs re-seeding. Each plug multiplies itself 50 times in few months. Spreads into permanent, perennial turf so thick and rich, insects, fungus & disease can't live in it. Ends need for weed killers; cuts fertilizer costs. Won't winter kill. Praised by LOOK, NEWSWEEK, NAT. GEOGRAPHIC, UNIVERSITIES, ETC. Plant that carefree lawn of your own—ORDER NOW!

### ORDER BY MAIL CUT OUT COUPON

To: Dept. 483, Zoysia Farm Nurseries  
602 N. Howard St., Baltimore 1, Maryland  
333 N. Michigan Ave., Chicago 1, Illinois

Please ship the following order of Amazoy Meyer Z-52

<input type="checkbox"/> 100 PLUGS \$9.98	<input type="checkbox"/> 100 PLUGS and Plugger \$11.98	<input type="checkbox"/> 300 PLUGS and Plugger \$24.98
<input type="checkbox"/> Full-size Plugger \$4.95		
<input type="checkbox"/> 600 PLUGS AND PLUGGER \$44.98		

If you live West of Miss. River, please add \$1.50 per 100 plugs for special handling and shipping. (We pay Postage E. of Miss. R.) Sorry No C.O.D.'s

I enclose . . . check . . . money order . . . cash

Name . . . . .

Address . . . . .

City . . . . . Zone . . . . . State . . . . .



**LICENSE PLATE FRAMES.** A new car rates them, an old one needs their dress-up touch. Durable plastic in white, black, yellow, green, blue or red. Fit standard 12" x 6" plates, are easy to attach. With Elks emblem or St. Christopher's Medal in gold color, \$1.50 a pair; without emblem, \$1.25 a pair ppd. Brock's Novelties, Dept. E, P. O. Box 151, Lunenburg, Mass.



**HONKY TONK PIANO RECORDS** "make" a party. Played by the No. 1 Honky Tonk Piano Man, "Keyboard" Kingston and his orchestra, these 26 tunes (including Crazy Otto Rag, many old Gay 90's favorites) are on 3 78 or 45 RPM records, or one 33 1/3 RPM. Specify speed desired. \$2.98 ppd. White House Co., Dept. PD-17, 8 Kingsland Ave., Harrison, N. J.

# FAMILY SHOPPER



**YOUR CHERISHED KNICK-KNACKS** will show off to advantage when you display them on this early American Wall Shelf. Wide bottom shelf might hold the family album or some finely bound books. 27" high x 20" x 6 3/4". In honey tone knotty pine or maple or mahogany finish, \$9.95 ppd. In sanded, easy-build kit, \$5.95 ppd. Yield House, Dept. E, No. Conway, N. H.

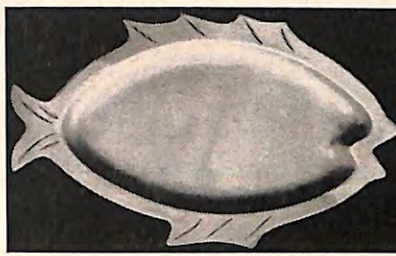

**FISH TO FRY**, bake or broil look better and taste better cooked and served on this cast aluminum Fish Platter. Patterned on the "sizzling steak" platters, it's a piece that can turn an ordinary meal into an occasion. Keeps food piping hot, will not warp. 19 1/2" long, 11 1/2" wide at its widest point. \$5.95 ppd. Downs & Co., Dept. E, Evanston, Ill.

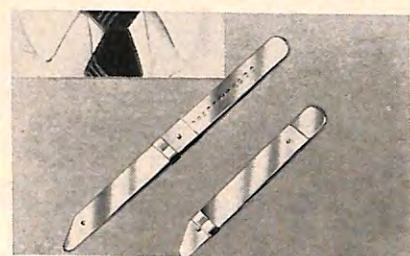

**ADJUSTABLE COLLAR STAYS.** No more frantic searching for the right pair of stays. Throw them all out and use this one pair of gold-plated, self-adjusting stays that fit any length collar. Non-curling. Here's a "little" gift with big appeal for Father's Day, graduation or "just because". \$1.00 a pair ppd. Nancy Norman, Dept. E, 422 Washington St., Brighton 35, Mass.

Except for personalized items, there is guaranteed refund on all merchandise returned in good condition within 7 days.

**BUG CATCHING COBRA LILY**  
"Nature's own flytrap"  
It actually catches insects out of the air! A real living plant—this exotic Lily destroys house flies, gnats and other small flying pests with the sureness of a cobra. Bugs that fly near disappear, never again to be seen. No sprays, messy powders or flypaper needed. We send you needs—ready for planting—and, in a few days, many tiny bonnets appear. In no time you have a lovely plant in delicate woodland shades with a speckled bonnet of paint brush reds and greens. Blooms indoors and out. Generous amount of seeds.  
**AN 8869 Cobra Lily \$1.00**

**Soap & Rinse Without Draining ANY SINK A DOUBLE SINK**  
Like 2 sinks in one! New polyethylene, cushioned Dual-Dishpan has separate compartments... one for sudsing—one for crystal-clear, soap-free rinsing. Cuts dishwashing time in half—saves hot water, too. Prevents chipping, conserves space. 17 3/4 x 13 1/4 x 6 1/2".  
**AN 9075 Yellow Dual-Dishpan: \$5.95**  
**AN 9076 Red Dual-Dishpan: \$5.95**  
Each \$3.49

**MAKE RUGS SKID-PROOF!**  
Just press—and end the menace of slipping rugs! Push-button Anti-Skid Rug Backing sprays any rug up to 9 x 12 feet with an invisible, floor adhesive undercoating. A wonderful safeguard for the entire family... from Grandma down to the wildest little Indian. Prevents dangerous slips and falls without the use of bulging stays or expensive pads. Takes only seconds to spray any carpet—regardless of shape. Won't rub off or harm rug. It's the easiest way we know to make every rug in your home completely skid-proof and safe. Large 11 ounce spray can.  
**AN 7716 Rug Spray \$1.98**

**Holds Up to 40 Pieces Dinnerware Caddy—\$1.89**  
No chipped dishes! No crowded cupboards! Dinnerware Caddy stores dishes in 1/2 the space... lets out disturbing others. Protective vinyl coating over steel prevents breakage. Holds 8 cups, saucers, plates—up to 40 pieces. 19 1/2" x 11 1/2" x 11 1/2".  
**AN 90215 Din. Caddy \$1.89**

**ECONOMY OVEN...only \$1.00**  
Bake! Roast! Toast! On top of your stove... on only 1 burner! Cook meat, potatoes, bun-rolls without ever lighting the oven or heating up the kitchen. Sturdy turn-resistant metal. Complete oven includes lid, grill, inner pan and grill base. Sturdy turn-resistant metal. Construction ideal for trips and summer cooking. Saves time and money. Ideal for leftovers.  
**AN 9061 Economy Oven \$1.00**

**Enjoy Cool Sea Breezes FAN AIR COOLER**  
Cool, refreshing comfort on the hottest, most sultry days! New Fan Air Cooler cools by evaporation—clips on any fan or vent in 5 seconds. Fill styron tank with water, insert special sponge and turn on fan. Circulates water-cooled breeze—not hot air. 8" in diameter.  
**AN 5763 Fan Cooler 98c**

## THE UNUSUAL ... AT BANCROFT'S ... THE DIFFERENT

**Dry Hair In Minutes HOME HAIR DRYER**  
Set or wash hair anytime—even after swimming—and take it down wonderfully dry in less than 10 minutes! Dryer Cap slips easily on vacuum or hand dryer; other end fits comfortably on head. Sends warm air gently throughout hair, gives beauty parlor results.  
**AN 7193 Hair Dryer \$1.00**

**Removes Corns, Callouses INSTANT CORN STICK**  
Applies just like lipstick and gives quick relief to corns and callouses. One application usually works wonders... no messy salves. Instant Corn Stick comes in handy stick form suitable for carrying in pocket or purse.  
**AN 8157 Corn Stick \$1.00**

**STRETCH TO HEALTH... REDUCE!**  
No pills! No diets! Here's the pleasant way to develop muscle tone and regain radiant health. Perfected in Hollywood, where health is wealth, Rubber Rowing Machine Exerciser makes it easy to lose unwanted weight. Folds for inconspicuous storage—comes with reducing chart. Ideal for men or women, gives enjoyable exercise in your own home.  
**AN 3785 Stretch to Health \$3.95**

**SPEEDY LIQUID "SANDER"**  
Miracle Liquid Sander disintegrates varnish, paint, lacquer and enamel finishes in minutes. Ends mess and hard rubbing usually associated with ordinary sandpaper, refinishes. Safe for hands and surface being sanded.  
**AN 7790 Sander, Pint . . . \$1.49**  
**AN 8782 Sander, Quart . . . \$2.69**

**Set Your Hair At Home PROFESSIONAL CURLER**  
New-type Professional Pin Curler sets hair in minutes. Simply insert curler in hair, roll and insert bobby pin. Instantly, the softest—yet tightest—ringlet ever. No waiting for hair to dry. Works equally well on wet or dry hair.  
**AN 4419 Pin Curler \$1.00**

**Won't Peel Or Rub Off REPLATE SILVER INSTANTLY**  
Just rub a little on with a cloth—that's all. Miracle Brand SILVER PLATER now makes it easy to replater worn silver at home. Replates ANY worn spot on Holloware, Sterling, Silverplate, Silvers copper, brass, bronze, etc. Not a polish, contains actual silver in suspension.  
**AN 1976 Silver Plater \$2.95**

**Amazing Relief For HAMMER TOES, CALLOUSES**  
Walk with new authority! Feel the difference instantly! New Hammer Toe Corrector stretches toe, helps hold it in proper position. Special cushion base helps ease callous pain at same time. Wear with any shoe. Specially show size, right or left foot, man or woman.  
**AN 7818D Toe Corr. \$1.00**

**HOW TO ORDER** • Order by number, size. • Add only 15c to each item stating quantity desired. • Send payment (check, money-order or cash) with order. No C.O.D.'s. Satisfaction guaranteed or money back.  
**SEND ALL ORDERS TO BANCROFT'S**  
2170 So. Canalport Ave., Dept. EL-973, Chicago 8, Ill.

**Self-Powered! Portable! VACUUM CLOTHES BRUSH**  
No electric outlet needed! Vacuum Clothes Brush sucks dust, dirt and lint into its own removable collecting bag. Carry it with you for clothes, car seats, etc. Cleans upholstery, drapes, blinds. Works on standard flashlight batteries (not included).  
**AN 7899 Vacuum Brush \$2.95**

## END GUTTER CLEANING NUISANCE

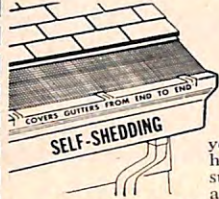

**FREE** brochure tells and shows how low-cost GUTTER-GUARD will save you money . . . spare you many hours of messy, hazardous work . . . insure 100% roof drainage efficiency the year round. GUTTER-GUARD Keeps Out leaves, twigs, buds, pine needles, bird nests, debris. Rust-resistant 3 ft. sections cover full length of gutter. Comes in 4 widths. Fits all wood and metal gutter types including copper and aluminum. LOW "FACTORY-TO-YOU" PRICES. Just send name and address on postcard. No obligation . . . no salesman will call.

MERIDIAN CO., Dept. 2GE, 366 Madison Ave., New York 17

## NEW! All Purpose-Accessory SEWING CABINET with Spindles and Pin Cushion

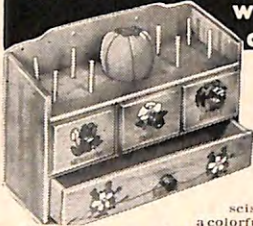

A place for everything—everything in its place! Compact (8 1/2" x 6"), yet roomy enough to store all your sewing necessities in the proper place. 4 drawers—each plainly marked, to hold needles & pins, snaps, utilities, & scissors. Top of cabinet holds a colorful pin cushion and 8 spindles for your thread. Entire cabinet is hand-somely lacquered and decorated in beautiful floral patterns. May be hung on wall or stand it on any surface. Mail your order today.

MEDFORD PRODUCTS, Dept. EL-5, Box 39, Bethpage, N. Y.

## NOW! TEST YOUR OWN TV & RADIO TUBES



All of them even picture tube!

Checks fuses, appliances, etc. Easy, safe. Insert tube in socket. Pilot light indicates if tube needs replacement. Rugged metal case. AC or DC. One service call saved pays for tester. Only 3.95 ppd. or C.O.D. plus charges. DeLux model 4.95. Instructions. 5-yr. Guar.

GEIGER ENGINEERING CO. Dept. PQ-100  
6349 N. Western Ave. Chicago, Illinois

## SEND 25c for this catalog of ALADDIN READI-CUT HOMES

Shows 120 modern plans, 5 to 8 rooms from \$3,000. (We pay the freight.) New 1957 Catalog in color now ready.



Send 25c to Dept. S-9.  
THE ALADDIN CO.  
Bay City, Michigan

## BUNION TROUBLE?

Get quick relief with sensational new Hallux-Valgus night bandage of Rohadur elastic material. Serves as a lever to restore normal toe position. Fits snugly, comfortably . . . helps where it hurts. Gives prompt, efficient relief amazingly fast. Aids in relieving the original, bunion-causing malformation. IMPORTANT! Specify shoe size, for man or woman; right or left foot. \$5.00

(Pair—\$9.00)

Postpaid. No C.O.D. Guaranteed, of course.

ELRON, INC.

225 W. Erie St. Dept. A-263 Chicago 10, Ill.



## End Dog Nuisance

Protect Evergreens, Gardens, Flower Beds, Lawns, Roses—also barbecue, chairs, auto tires, garbage cans, etc. With a flick of the finger, this new CHAPERONE Aerosol spray can makes America's favorite tried-and-true repellent even easier to use! Dogs, cats, rabbits KEEP OFF. Invisible, harmless, long-lasting. Generous Economy-size Aerosol Chaperone, \$1.49 postpaid. FOR LARGER YARDS, use the old reliable Liquid Chaperone in hand sprayer—Quart Can \$3.98 postpaid. INDOOR USE—Powder Chaperone for dogs \$1; Kitty Chaperone \$1. Money-Back Guarantee. Send check or M.O., we pay postage. SUDBURY LABORATORY, Box 88G Sudbury, Mass.

## Lightning Calculator

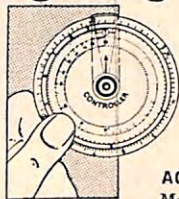

Germany's latest simplifies all calculations, multiplication of discounts, percentages and profits

JUST TURN THE DISC AND READ THE ABSOLUTELY ACCURATE RESULTS

Made of fine aluminum just three inches in diameter, it does the work of a ten-inch slide rule, fits in a vest pocket. Complete with easy to follow instruction booklet. In Plastic Case \$6.95 Prepaid. 10-day Money-Back Guarantee. PROGRESSIVE ENTERPRISES, INC. 135 W. 20th St., N.Y. 11, N. Y., Dept. EK-1



## WRAC Driving Range

groove your swing—develop form

Special \$8.95 post paid use full power swing

correct hook and slice

Home golf range Practice with real balls and see how fast you improve your golf! Play the equivalent of 18 holes in 20 minutes and keep score! If you shoot in the 90's, our special scoring target will score you in the 90's. Within a month you'll be scoring in the 80's. Set comes complete with two poles, nylon catch, practice and scoring instructions. Only \$8.95. Send to WAMO MFG. CO., Box 3-A, San Gabriel, Calif.



## GET RID OF BUGS!—\$1

Amazing new MAGIC BUG-STRIPS can rid your home of flies for a whole season! Self-adhering 3/4" x 2 1/4" Strips contain miracle Malathion. Just press to underside of chairs, tables, window-sills, screens, doors—completely hidden and out of the way. No muzz . . . no fuss . . . no fumes . . . no sprays! Use indoors or out. Also kills ants, roaches, silverfish, mosquitoes, flying moths, etc., by contact. 32 Strips for only \$1, postage paid. Guaranteed to do the job or your money back! Order MAGIC BUG-STRIPS direct by mail from Sunset House, 216 Sunset Bldg., Hollywood 46, California.

## Elks Family Shopper



ROSEBUDS BLOOM FOREVER on this exquisite jewelry from Venice. The lovely buds and flowerlets are hand-painted on sky-blue beads laced with shimmering gold. 15" choker, \$5.50 (other lengths to order); bracelet, \$3.30; earrings, button or drop (screw-back or pierced), \$1.65. Set, \$9.50 ppd. Alpine Imports, Dept. EL, 505 5th Ave., New York 17, N. Y.

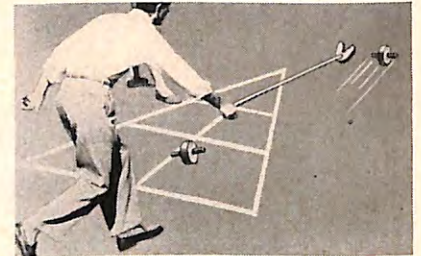

SHUFFLEBOARD IN YOUR OWN BACKYARD. These pucks are specially balanced to roll accurately on grass for 25 to 75 feet. Or move peg so that puck slides flat for conventional floor or deck shuffleboard. Complete with 2 cues, 4 bright-colored pucks, 2 scoring courts, \$9.95 ppd. Wamo Manufacturing Co., Dept. J, 835 E. El Monte St., San Gabriel, Calif.



CANDLE GLOW and green leaves do wonders for a room gone dull with age. Hurricane Lamp Planter consists of wrought iron with glass lamp set in steel-hooped Vermont sugarin' pail fitted with removable waterproof liner. Hand-rubbed old maple finish. 15" high, 7 1/2" diameter. With candle but not leaves, \$5.95 ppd. Puddin' Holler, Dept. E5, East Swanzey, N. H.

Save these Elks Family Shopper pages. They make a handy catalog of gift items for all occasions.

# Lodge Visits of FRED L. BOHN

## Grand Exalted Ruler Attends New York Lodge Banquet

New York Lodge No. 1 celebrated its 89th Anniversary, which marked the birthday of the Order, at a dinner and dance in the Sheraton-Astor Hotel, February 23rd, with 750 in attendance. Among the distinguished guests were Grand Exalted Ruler Bohn and Past Grand Exalted Rulers James R. Nicholson, William Hawley Atwell, James T. Hallinan, Henry C. Warner, Joseph B. Kyle and William J. Jernick; Grand Treasurer Edward A. Spry; James A. Gunn, Grand Lodge Committee on Lodge Activities; District Deputy Gordon H. Meyer; Francis P. Hart, New York State Assn. Pres.; James A. Farley and Franklin J. Fitzpatrick, Past Pres. of the N. Y. State Assn.; Vice Pres. Robert Fisher of the State Assn.; John F. Scileppi, member of the Grand Forum; Earl Pitzer, Past Pres. Penna. State Elks Assn., and Carmine DeSapio, New York's Secretary of State and long a member of No. 1; Rev. Col. Benjamin A. Tintner and Rev. Patrick B. Fay.

Exalted Ruler John J. Mangan introduced  
(Continued on page 36)

At the dais during the 89th Anniversary Dinner-Dance of New York Lodge No. 1, on February 23rd, were from left: Past Grand Exalted Ruler James T. Hallinan, Grand Exalted Ruler Bohn, Past Exalted Ruler James P. Somerville, Chairman for the arrangements, and Exalted Ruler John J. Mangan.



Greeting Grand Exalted Ruler Bohn when he arrived at the airport at Huron, S. D., were from left: Past District Deputy Keith Potter, Past Grand Exalted Ruler James G. McFarland, Exalted Ruler Ross B. Matson, (Mr. Bohn), Past Grand Trustee Ford Zietlow, Mayor E. F. Karstens and State President L. J. Gregory.



When Grand Exalted Ruler Bohn visited the Elks of the State of Rhode Island on February 24th, present from left were: former Chief Justice Grand Forum Judge John E. Mullen, Judge John P. Hartigan, District Deputy Fred Quattromani, (Mr. Bohn), State Pres. Dr. Edward C. Morin and Judge Francis B. Condon. The reception and dinner was held at the Biltmore Hotel in Providence.



At the 47th Anniversary banquet of the Mass. Elks, held in Boston in Feb., seated from left: Lt. Gov. Robert Murphy, G.E.R. Bohn, Acting Mayor William Foley, P.G.E.R. E. Mark Sullivan and Judge John E. Fenton, member Com. on Judiciary. Standing from left: P.G.E.R. John F. Malley, Judge Wilfred Paquette, Toastmaster, State Pres. John Murray, Grand Treasurer Edward A. Spry and William Hogan, Grand Lodge Ritualistic Committee.



Zanesville, Ohio, Lodge, of which Grand Exalted Ruler Bohn is a member, celebrated its 68th Anniversary on February 28th and gave a banquet in his honor. At the guest table, center foreground: Grand Lodge Activities Committee member Nelson E. W. Stuart, and to right, Mr. Bohn, Exalted Ruler A. D. Carpenter, lodge officers George Blaho and Cecil Baughman, District Deputy Paul T. Reed, Lawrence Derry, P.D.D. Thomas J. Price, Secretary to Grand Exalted Ruler James W. Plummer and H. M. Scott.



R. D. Bonnell, Pres. of the Elks National Bowling Assoc., presented Grand Exalted Ruler Fred L. Bohn with a \$1,000 check for the Elks National Foundation at the opening of the tournament at Columbus, Ohio, on March 2nd. Others present from left: Local tournament chairman George Moon, Exalted Ruler Victor Pearce, Columbus Lodge; Past Grand Tiler Irvine J. Unger; officers of the Elks National Bowling Association E. N. Quinn and Joseph Krizels.

# NEWS of the LODGES



Above: A total of 410 years in Elksdom was represented by 12 members of Escondido, Calif., Lodge at its Old Timers Night. Nine of these veteran Elks are pictured with candidates initiated that evening and, background, P.E.R.'s of the lodge. The Old Timers in the foreground are, left to right, R. J. Cacy, Sr., Harry Robertson, L. T. Ward, Dr. Clarence Ridley, Ben Pfusich, Joseph Joosten and Robert Roberts; at left of second row are Howard Daley and Oren Manker.



Above: This beautiful float, based on the theme, "Charity is the Heart of Elksdom", depicts the work of the California Elks' Major Project in the treatment of cerebral-palsied children. It won the sweepstakes award over 20 competitors for Indio, Calif., Lodge in the street parade held in conjunction with the Riverside County Fair and National Date Festival.



Above: Phoenix, Ariz., Lodge's \$1,700 March of Dimes check is held by Co-Chairman Walter D. Stull, left, and County Chairman Keith Winston.



Above: Ellensburg Lodge's officers won the Washington State Ritualistic Championship at Vancouver. Left to right, foreground, are Chaplain Louis Clerf, E.R. Robert W. Daggett, Est. Lect. Knight Clarence Helgeson, Inner Guard William Robertson; second row: P.E.R. and Coach James Geoghegan, Tiler Lloyd Mullins, Esq. Robert Cole, Est. Lead. Knight Francis Weger and Est. Loyal Knight Robert Woods.



Left: E.R. Edward J. Saal, Jr., left, is pictured with Ernest P., Herman M., Peter and Eugene A. Ceccon, recent initiates of Willows, Calif., Lodge.



**Downey, Calif., Lodge  
Instituted**

Assisted by officials of Huntington Park Lodge, Past Grand Exalted Ruler L. A. Lewis conducted the ceremony which made Downey Lodge No. 2020 a reality.

In addition to 196 members received on transfer dimit, the newest branch of fast-growing California Elksdom began existence with 308 Charter Members. Larry Stevens was elected first Exalted Ruler at this program which took place at the El Rancho High School in Rivera.

**Redwood City, Calif.,  
Elks Open Home**

Instituted in February, 1956, with a record 753 members, Redwood City Lodge No. 1991 now not only boasts a roster of 852 but is ensconced in its own home. The gala opening party was attended by about 550 Elks, and guests included John B. Morey of the Grand Lodge Ritualistic Committee and P.D.D. Eric Silva.

The new headquarters of this lodge is a former 21-acre private estate purchased by the lodge for \$130,000 and remodeled at a cost of \$20,000. The entire lower floor has been redesigned by architect Bernard Nobler, a member of the lodge, and Elk Robert A. Baker did the contracting work which involves a glassed-in patio, expanded living rooms and kitchen and other features. Later a swimming pool and golf course will be added, as well as a picnic area for the use of the lodge members and other organizations.



At the home of San Diego, Calif., Lodge a class was initiated in honor of the Secretaries of Southern California by a team composed of the Secretaries in addition to P.E.R. Robert F. Ellerman, former Secy. of Denver, Colo., Lodge. Host officials appear in the background with the class and in the foreground are the presiding officers, together with D.D. James H. Loftus and State Vice-Pres. Frank Bowden who was making his official visit to San Diego Lodge at that time.



E.R. C. W. Odom of Clovis, N. M., Lodge is pictured, seventh from left background, with his fellow officers and the class they initiated in honor of State Pres. Fred H. Dilley, Jr.



Above: The sixth annual major-minor league baseball game played for Redondo Beach, Calif., Lodge raised \$1,000 for crippled children. Players who donated their services included, standing, left to right, William Simas; Jim Marshall of the Chicago White Sox; Tom Saffell, Pirates; former Yankee John Lindell; Mgr. Bill Sweeney of the Portland Beavers; Eddie Bockman, Cleveland Indians; Del Crandall, Milwaukee Braves; Gus Zernial, Kansas City Athletics, and Est. Lead. Knight Jim Ciallella; foreground: Irv Palica, Baltimore Orioles; Peanuts Lowery, St. Louis Cardinals; Eddie Stewart, White Sox; former N. Y. Giant Tuck Stainback; Bobby Adams, Cincinnati Reds, and Nels Burbrink of the Cardinals.

Below: Photographed when Ashland, Ore., Lodge dedicated the new addition to their home in the presence of 1,200 members and guests were, left to right, Esq. Sam Davis, F. G. Warren, Edwin J. Alexander, former Chairman of the Grand Lodge Committee on Lodge Activities who was the principal speaker, Asst. Esq. Moon Mullins, E.R. William O'Brien, P.E.R. Roland L. Parks, Est. Lecturing Knight R. Herndobler, Est. Leading Knight Leo Zupan and Est. Loyal Knight James Madison.





During Terre Haute, Ind., Lodge's combined celebration of the Order's Anniversary, P.E.R.'s and Old Timers Night, a class was initiated in the presence of D.D. Roland Campbell. Among the candidates was Robert Weust, right, pictured as his father, Elk Harry Weust, congratulated him in the presence of his brothers Harold and Harry, Jr., also Elks.



Willimantic, Conn., Elk officials won the 1957 State Ritualistic Title and the trophy presented by Chairman Arthur J. Roy of the Grand Lodge Committee on Lodge Activities, a P.E.R. of that lodge. The accomplished team is pictured with P.E.R. Edward E. Arnold, coach, left background, and Inner Guard Eric Lind, Candidate, right background.



Not long ago the Entertainment Committee of Sharon, Pa., Lodge presented the first set of new jewels of office in the lodge's 66-year history. Committee Co-Chairmen Harold Robbins, left, and George Crishon, right, were pictured as they placed the jewels on E.R. Wayne C. Thompson, second from left, and Secy. John T. Lyons, P.D.D., second from right. Looking on are Committee members Richard Scragg and Cecil Phillips.



Photographed during the Conference conducted by D.D. Friend L. May at the Elks National Home in Bedford, Va., at which Supt. Thomas J. Brady was host, are, left to right, E.R. E. W. Mays of Clifton Forge Lodge, Danville E.R. W. L. Oakes, Past Grand Exalted Ruler John L. Walker, D.D. May, Roanoke E.R. Charles M. Oakey, Lynchburg E.R. H. W. Mead, E.R. Roy Harlow of the Home Lodge and Martinsville E.R. S. E. Shumate.



Above: P.E.R. W. B. West, left, and E.R. L. W. Ferguson, right, use a saw to cut the cake marking the Order's 89th Anniversary and the 52nd birthday of Tulsa, Okla., Lodge as Est. Lead. Knight Lorin Hedrick, second from left, and Loyal Knight Carl Britton supervise.



Above: Among the 55 Old Timers honored by Wausau, Wis., Lodge not long ago were, seated left to right, 52-year Elk Harry Hummell, 56-year member Sam Winkelman and 55-year member Hon. J. J. Okoneski. Standing are E.R. G. G. Lella, right, and Est. Lead. Knight D. A. Gorman.

Right: TV star Fred Kirby is pictured in the background with children of the Church Home Orphanage who were guests of Rock Hill, S. C., Lodge at a banquet, movie and entertainment. Est. Lead. Knight Lem Holroyd presided, and gifts donated by the Elks were presented.



(Lodge News continued on page 35)

with Ed Faust



# In the Doghouse

**Dalmatians can do lots more than chase after fires.**

IN ENGLAND he's sometimes affectionately called the plum pudding dog. In America Mark Twain said he wasn't sure whether it was a white dog with black spots or a black dog with white spots. But to anyone knowing that spotted pooch, he's a Dalmatian, perhaps one of the most oddly colored of all dogs. In those distant days when his Highness the Horse was still King, the Dalmatian was a pretty important person. No well-organized fire house was without him and in many a private and public stable he was considered a very necessary associate. Today's youngsters can have their rocket planes and space ships but, Ah Me!, they'll never know the thrill of hearing the clanging, banging, horse-drawn fire engine roaring down the street paced by a Dalmatian and leaving in its wake a stream of sparks, smoke and enthusiastic small boys. Yes, the Dalmatian was a true fireman but more than that, a devoted follower of the horses.

Why this breed is so strongly and strangely attracted to Dobbin is one of those mysteries of Nature, but the attraction is there and has been since 'way back when. My own private crystal ball tells me that this is so because the Dal, as he's known, is an independent sort of fellow likely to scorn the restrictions of his master's home for the freedom that usually marks most places where horses are stabled. But he's an amiable dog, highly intelligent, clean and easy to keep clean and in this motorized age has little, if any, reason to go stable hunting. Other than his color there's nothing odd about him. That color by the way, while usually black on white, is sometimes varied to brown on white.

If you happen to have a Dalmatian, note please, that the standard for the breed in both varieties of color specifies the black or brown spots to be distinct and well defined and about of a size varying from that of a dime to a half dollar. Large, solid patches of color are viewed with disfavor by both breeders and dog show judges.

When the breed originated nobody knows, although there exist frescoes on walls of ancient Egyptian tombs that portray dogs strangely spotted like the modern Dalmatian and greatly resembling it in conformation. Where the breed originated is another mystery, but the Dalmatian Club of America, composed of

breed enthusiasts, agree that authoritative writers first place the dog as a native of Dalmatia, originally a province of Austria. He's an accommodating dog, having been effectively used in war for sentinel duty as well as for herding and hunting. He's remarkable, too, for his memory. I assure you that this is a fact, having owned or been owned, I'm not sure which, by one of these dogs some years ago. If Skip were around today I'm sure he could take care of his own income tax.

WHILE the American Kennel Club, governing body for pure bred dogs, classifies the Dalmatian as a non-sporting dog he's anything but that, for he is very much a sportsman. This is only one man's opinion but I hold a belief that somewhere along the family tree of the Dalmatian there's an infusion of pointer blood. Just when or where this occurred; well your guess, if you care to make one, is as good as mine.

In the bygone days of the stage coach the Dalmatian was particularly useful as a guardian. He would jog along underneath the coach or sit at the side of the driver. When the coach stopped for a

change of horses, his job was to guard the baggage. Even in those early days the wicked were flourishing and our friend the Dalmatian's job was to see that they didn't flourish by tampering with the baggage at certain wayside taverns.

The greatest use of these dogs was from about 1800 to 1850. More people were traveling by stage coach at that time than perhaps during any other period. It was then that the Dalmatian became known as the coach dog, and coach dog he is today in the minds of many who don't know his true family name. There's scarcely a breed that has had more nicknames attached to it; he's been called the plum pudding dog, the fire dog, the coach dog, the spotted dog and even the leopard dog. Yes, and during the years immediately before Mr. Ford gave us the model T, the Dalmatian was known as the carriage dog.

Another point in favor of this good dog is that he'll declare himself if need be, but only when the need really exists. At such time the wise owner will heed the warning. But motorized age notwithstanding, you'll still find one of these speckled beauties here and there around firehouses  
*(Continued on page 45)*



*Three typical Dalmatians with markings of similar sizes.*



# TRAVELGUIDE

Mexico, always a favorite vacation land for our traveling readers, will warmly welcome a great number of Elks after the Convention this year in San Francisco. This prediction is based on the number of requests on the Mexican Post Convention Adventour. This tour will spend a week in Mexico and all the many wonders and unusual attractions to be found south of the border will be included. The best hotel and restaurant accommodations are already engaged and, with English speaking guides who know all the answers, this tour will be unforgettable. Write us for the official folder, or to Mexico Ramirez Tours, Rhin 29, Mexico 5, D. F.

★ ★ ★

*Post Convention Tour interest this year seems greater than ever—no doubt because of the numerous opportunities offered for an unusual vacation. In addition to Mexico, requests are arriving every day for the folders of the several other tours offered our readers. The 4th Annual Elks Hawaiian Tour, The Alaska Elks Tour to the Land of the Mid-Night Sun and the Grand Exalted Ruler's Train and tours in connection with that All-Elks Special. Write to us for these folders. We are sure you will be interested in one of these many tours following the Convention this year.*

★ ★ ★

The following month—August—offers the annual Inter-Tribal Indian Ceremonial at Gallup, New Mexico, August 9th through 11th. This is "Today's Greatest Living Tribute" to the American Indian and is witnessed by increasing thousands of tourists each year. This year an expanded program of dances, parades, races and rodeos make it a must for any of our readers who plan to be in the Southwest this summer. Gallup has 10 hotels and 36 motels, so visitors will find adequate and modern accommodations. We have the folders, or write Indian Capital Memorial Commission, P. O. Box 1029, Gallup, New Mexico.

★ ★ ★

*And for those of our readers who plan to be in the neighborhood of Yellowstone, there will be eighty days of Rodeo from June 15th to Labor Day at West Yellowstone, Montana. The Rawhide Rodeo is a family affair and the answer to the question of what to do that is different and exciting in the evenings. If you are within reasonable distance of this event, you will miss something if you do not attend.*

★ ★ ★

Dan Sanborn, our good friend on the Mexican Border who does such a wonderful job of guiding and counseling our many visitors to Mexico, has sent along a new and very

complete folder on Mexico. Any of our readers planning to visit Mexico this year should have this material and we will send it along to those who write to us.

★ ★ ★

*The Caribbean Tourist Association is making plans to welcome an increased number of summer tourists this year. Even the "off-the-beaten-track" resorts are sprucing up for the expected rush. Nevis, a fifty-square-mile island, is expecting a boom this year in honor of the great American statesman born there on January 11, 1757—Alexander Hamilton. Special guides are being trained to take visitors to the historic spots including Hamilton's birthplace. Four cruise ships will call at Nevis this year and many special excursions are being planned from near-by St. Kitts.*

★ ★ ★

Alaska is another tourist spot creating a lot of interest this year judging from the requests for information. With an extra ship making the run—"S.S. Coquiltam"—and the regular service of the Canadian Pacific's "Princess Louise" and Canadian National's "Prince George," there will be 39 cruises to Alaska this summer. If you are planning to drive and would like to

ship your car back and come home by boat, you will be able to do so from Whitehorse to Vancouver for \$121.

★ ★ ★

*Our European traveling readers on the West Coast may now fly from San Francisco to London via British Overseas Airways. This service was inaugurated on April 2nd from London, with the first flight out of San Francisco on April 4th. Round trip fares include a 15-day excursion rate of \$623. The normal tourist fare is \$720.*

★ ★ ★

The present-day skiing enthusiast need no longer hang up his skis when the weather turns warm in most of the country. There is no "closed season" at Timberline Lodge, high on the slopes of Mt. Hood in Oregon. The Cascade Mountains offer some of the finest skiing during the spring and even as late as July and August. The Lodge is located 63 miles from Portland and round trip bus fare is \$3.61. Passengers are met by Timberline station wagons at Government Camp for a six-mile drive to the Lodge. United Airlines serves Portland from all over the U. S. with speed, comfort and low fares.

## For Elks Who Travel

(Continued from page 15)

such resort-like sports as tennis and swimming. The nights bring dancing, campfire programs, movies and the nightly fireball, when a flaming bundle is dropped over the side of a canyon wall. The burning cascade is pitched over the valley's rim at Glacier Point where the drop is an awesome 1,000 feet.

When it comes to accommodations, Yosemite has a choice of half a dozen places ranging from the outdoorsy swank of the Ahwahnee to a bathless wood cabin. For instance, the Ahwahnee, which is only on American plan (with meals), extracts \$22 a day for one person in a room, or \$17 to \$18 a day if two occupy the same room. Now, then, at Camp Curry four persons in a tent could make it for \$2 each, or \$7.50 each with food. A wood cabin without bath but with meals is \$8.50 with two in a cabin. In between these extremes is the Yosemite Lodge, Big Trees Lodge, the Glacier Point Hotel, Wawaona Hotel and the Tuolumne Meadows Lodge. The last named has canvas cabins at \$2.50 per person (two in a room) and the other places average out at about \$8 a night, or \$12 to \$16 with food.

A six-day saddle trip departs every Saturday and Sunday in season and makes a tour of the High Sierra camps, staying one night in each. There is time for resting, fishing and sightseeing en route, and although it comprises a fifty-mile excursion through virgin country, women and children are invited. The tab comes to \$79, which includes a saddle mule, a shower bath (listed in order of necessity), a guide, dormitory lodgings and all meals. Private tents can be rented on advance

notice. The seven-day hiking trip looks in at five High Sierra Camps and ought to be all right as long as you're used to high level hiking. Hoofers leave by bus every Monday—an ideal way to start a hiking trip—starting in the valley and riding up to the rim which is a rough climb even for a bus. The bus transportation, lodging in dormitory tents, shower bath at each camp and the services of the guide bring the entrance fee to \$24 here and meals are extra. Figure about \$6 a day. No more than 15 are taken in a group and kids between 12 and 18 are welcome if accompanied by an adult.

South of Yosemite but still easily reachable from San Francisco is Sequoia and King Canyon National Parks, two preserves that adjoin each other. Sequoia, which was founded in 1890, is second oldest of the U. S. parks, whereas King, founded in 1940, is one of the newest. Although there are 32 known groves of giant trees inside the park, the Park Service says it is possible that other groves might exist but have been passed unnoticed. The largest tree in Giant Forest is the General Sherman Tree, 36.5 feet in the beam and 272.4 high.

While the trees are large the rates are modest at Sequoia. Rates at Giant Forest Lodge are roughly about \$10 per person, which includes food, but anybody who is a Spartan can make it in a bungalow tent cottage with three other room-mates at \$1.75 per each. United Airlines, the Santa Fe, and the Southern Pacific all service the park, which is 180 miles from Yosemite and 270 miles from the Golden Gate.

# News of the Lodges

(Continued from page 32)

## Bradford, Pa., Lodge Anniversary Observed

Bradford Lodge No. 234 marked its Golden Jubilee with a dinner and social program at which tribute was paid to four living Charter Members and Old Timers of 45 or more years' affiliation. Two of the original Bradford Elks were on hand, P.E.R. Herbert H. Black and Joseph Ball. Not able to attend were P.E.R. J. W. Hurley, now a resident of Tulsa, Okla., and Timothy E. Costello. As a symbol of the anniversary, E.R. Ferris Thompson presented a 50-year membership pin to George Kretz, who boasts the longest continuous service to the lodge in addition to that of its Charter Members.

The lodge home was suitably decorated for the occasion under the Chairmanship of Elmer V. Kelly, Jr., and a fine entertainment program was presented.

## Connellsville, Pa., Lodge Home Rededicated

A four-day series of events marked the completion of the extensive renovating job on the home of Connellsville Lodge No. 503. Highlight of the program were the cornerstone-laying and rededication at which D.D. Homer Huhn, Jr., Mayor A. I. Daniels, P.E.R., General Building Committee Chairman James E. Goddard, P.E.R., and E.R. H. A. Hild and his officers officiated. Other participants included State Pres. A. L. Heisey, Past. Pres. F. T. Benson, P.D.D. C. H. Ellis and So. Dist. Pres. M. A. Shust.

The decision to rebuild the home which had been remodeled three times since the Elks erected it over 40 years ago was made in September, 1955. Completely modernized and refurnished, it has been rebuilt to suit every need of the membership.



BURBANK TEST PILOT says:

"Experimenting is my business, but when I shop I don't take risks..."

I'm always satisfied most with a BRAND that's made a NAME for itself!"



MANUFACTURER

### "I MADE IT

...the best, most up-to-date product available for the money. I can't afford to cut corners or compromise on quality. If people became dissatisfied with my product, they'd simply stop buying it."

### "I SOLD IT

...recommended it to my customers because the brand has made a name for itself. When I sell a well-known brand, I know the customer will be satisfied. And satisfied customers keep me in business."



DEALER

### "I BOUGHT IT

...by brand because that's the surest way I know to get exactly what I want. I can't risk my money on mistakes. When I ask for brand names, I know I'm getting the best and the safest buy."

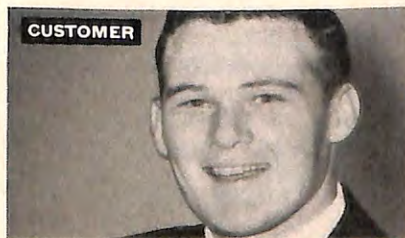

CUSTOMER

## STATE ASSOCIATION CONVENTIONS

STATE	PLACE	DATE
New Mexico	Carlsbad	May 2-3-4
Kansas	Wichita	May 3-4-5
Missouri	Joplin	May 3-4-5
Nebraska	Hastings	May 3-4-5
Georgia	Augusta	May 9-10-11
Oklahoma	Muskogee	May 10-11-12
New York	Albany	May 16-17-18
Utah	St. George	May 16-17-18
Wyoming	Casper	May 16-17-18
Ohio	Columbus	May 16-17-18-19
Alabama	Montgomery	May 17-18-19
Arkansas	Fayetteville	May 18-19
Kentucky	Owensboro	May 23-24-25
North Carolina	Salisbury	May 23-24-25
Florida	Orlando	May 24-25-26
Illinois	Springfield	May 24-25-26
Louisiana	Shreveport	May 24-25-26
New Hampshire	Manchester	May 25-26
Arizona	Nogales	May 29-30-31
Oregon	Coos Bay	June 1-2
Iowa	Des Moines	May 30-31 June 1
Texas	Galveston	May 31 June 1-2
Wisconsin	Fond du Lac	June 5-6-7
Minnesota	International Falls	June 6-7-8-9
Indiana	Evansville	June 7-8-9
Michigan	Grand Rapids	June 7-8-9
South Dakota	Brookings	June 7-8-9
Vermont	Brattleboro	June 7-8-9
North Dakota	Fargo	June 9-10-11
Washington	Walla Walla	June 13-14-15
South Carolina	Myrtle Beach	June 14-15
New Jersey	Atlantic City	June 21-22
Maine	York Harbor	June 21-22-23
Massachusetts	Plymouth	June 21-22-23
Rhode Island	South Kingstown in Wakefield	June 22-23

THE BRANDS YOU SEE ADVERTISED IN THIS MAGAZINE ARE NAMES YOU CAN TRUST!

They stand firmly behind every product and claim they make.

BRAND NAMES FOUNDATION, INC. • 437 FIFTH AVENUE, NEW YORK 16, N. Y.

## Lodge Visits

(Continued from page 29)

duced Grand Exalted Ruler Bohn, the evening's principal speaker. Esteemed Leading Knight James J. Carr presented Past Grand Exalted Ruler Hallinan with a check for \$500 for the Elks National Service Commission, and Brother Hallinan promptly turned it back to New York Lodge as the first contribution to the Lodge's building fund. Delegations from numerous New York and New Jersey lodges joined in the anniversary celebration. Past Exalted Ruler James P. Somerville presided.

### Mr. Bohn Honored by Elks of Rhode Island

Accompanied by Grand Treasurer Edward A. Spry, on February 24th Grand Exalted Ruler Fred L. Bohn visited the Elks of the State of Rhode Island. On their arrival at Union Station in Providence, they were met by a large delegation of Elks headed by District Deputy Fred Quattromani, State President Dr. Edward C. Morin and the Boy Scout Troop from Providence Lodge. In the evening a reception and dinner were held at the Biltmore Hotel with over 400 Elks from the eight lodges of Rhode Island attending.

## Danger Struck

(Continued from page 7)

tonight?" Mr. McHugh called from the front of the store. "It's getting kind of late."

"I know," Davie said, shaken out of his thoughts of the famous western lawman. "I'll just wait a few more minutes." And while waiting he'd have time to imagine how Gary Cooper might portray the role of Wyatt Earp in a tense moment at sun-up, striding down a quiet street while from doorways of—

"All right, Davie," and the clank of glasses told him Mr. McHugh was occupied again.

Davie glanced at the clock, then at the mirror showing the store front. One of Davie's brows went up, and his mind shifted over to the illustrious Doc Holliday when he was . . .

Davie knew his western heroes, knew their deeds, their mannerisms, their everything. It was one of Davie's harmless pastimes when he occasionally identified himself with the likes of a quick-on-the-draw sheriff, a shrewd-trading pioneer with a trusty Remington, and even the likes of a noble Indian chief.

A pastime, a daydream, in the fashion of a boy his age. If anywhere in it there was the faintest molding of character, Davie Vernon was far from aware of it. Certainly not in the fact that he often adopted a slouching stance the way he'd seen Gregory Peck portray a western gunfighter on the screen. Or in the way Davie sometimes drawled his speech, imitating John Wayne. Even here, in Mr. McHugh's

Among those present were Governor Dennis J. Roberts, of Providence Lodge; Lt. Governor Armand H. Cote, of Pawtucket Lodge; Judge John P. Hartigan, Associate Justice of the Supreme Court of the State of R. I., and a member of Pawtucket Lodge; Judge John E. Mullen, of the Superior Court of the State of R. I., a Past District Deputy and a member of Providence Lodge; Brother George Dolan of Westerly Lodge, a Past District Deputy and the oldest living Past Pres. of the State Association. The Toastmaster of the evening was Judge James E. Leighton, Vice President of the State Association. Past Exalted Ruler C. Max Turcotte of Pawtucket Lodge was Chairman.

### Zanesville Celebrates 68th Anniversary

The Grand Exalted Ruler's home lodge, Zanesville, Ohio, celebrated its 68th Anniversary on February 28th, and honored Mr. Bohn and Past District Deputies Thomas J. Price and Harold V. Tom at a banquet.

The program was under the direction of Cecil Baughman. Following the banquet, 150 Brothers attended a special meeting at which a class of twelve candidates was initiated. James W. Plummer, Secretary to the Grand Exalted Ruler and Vice Presi-

dent of the Ohio Elks Assn., presented honorary life memberships to Brothers Price and also to Brother Jack Tom on behalf of his father, Harold V. Tom.

Present for this outstanding occasion were Grand Lodge Activities member Nelson E. W. Stuart, District Deputy Paul T. Reed, and State Assn. officers Lawrence Derry and Harold M. Scott.

### Grand Exalted Ruler at Huron Lodge for Mortgage Burning

February 19th was a big day for Huron, S. D., Lodge. It was the occasion not only of the burning of the final mortgage bond on Hotel Marvin Hughitt lodge home, but also a visit by the Grand Exalted Ruler, who arrived shortly before noon.

Mr. Bohn was greeted by a large delegation, headed by Exalted Ruler Ross B. Matson and Past District Deputy Keith Potter. Past Grand Exalted Ruler James G. McFarland, State President L. J. Gregory and Past Grand Trustee J. Ford Zietlow were on hand. Huron Lodge held a luncheon for the visiting Elk dignitaries and in the afternoon initiated a class of 40 candidates. A dinner was held that evening. The occasion received outstanding attention from "The Huronite and the Daily Plainsman" and Radio Stations KIJV and KELO-TV of Garden City.

place, Davie had a habit of imagining himself sitting not in a soda parlor booth but being at a poker table in a gold mining town of the old west.

Now a gunfighter would never have put his back to the door, and Davie was aware of it. Mr. McHugh's place had a door leading out back to the alley, and the alley led to the street. Davie had long ago discovered this, the way Hickok or Earp would have paid heed to such small things. Not that Davie was planning to use the back door to the alley. It was all in the realm of daydreaming, the illusion of make-believe for a youngster nearing eighteen who'd maybe read too many stories of famous westerners and had then found it pleasant imagining himself in their boots, quick on the draw and out-guessing any bad "hombre."

Davie thus sat with his back to the front door—the thing Earp would never have done!—to preclude the possibility of being recognized by, say, a neighbor who might then tell his father or mother. And yet, with his back to the front, Davie was in control of the view—just the way Earp would have been—by watching that mirror strip ornamenting the far wall. The mirror reflected a bare fifteen-inch length and a six-inch width, but it was enough to see the front of the store, the doorway, and the avenue outside.

Davie tasted his soda with no particular interest, then looked at the clock again.

"Almost time to lock up," Mr. McHugh called over the counter, wiping his hands with a towel.

Davie leaned back and stretched his legs under the table, Gary Cooper fashion. He felt a little hurt about Eileen not

showing up, but at his age Davie merely shrugged it off. He'd see her at school in the morning. His mind, instead, went to Doc Holliday, wondering if the great gunfighter ever had much trouble with his women, and from this thought Davie went on to visualize himself, chaps slapping as he strode across the saloon boardwalk, his Colt swinging heavy and low against his right thigh, his Stetson tipped back to show his face, handsome but rugged—

Davie leaned a little in order to see himself in the ornamental mirror. Well, in another couple of years his face might get to looking harder than it did now. Davie then bent up his legs, about ready to slide out from behind the table, his right hand making a scooping move at his thigh, as if his low-slung gun were in the way. The mirror still showed the front doorway, and now in addition showed the two young "hombres" entering.

Davie paused, watching the quickness of their movements in the mirror. He saw one of the men go through the opening between the counter and the small table where the cash register stood.

Mr. McHugh saw them too, and rushed forward. "Hey! What's the idea!"

Davie suddenly sat frozen in his seat, his eyes fixed on the mirror, as if the reflected action was part of some television play. What he was seeing appeared harmless enough, nothing more than two "hombres" hurrying into a soda parlor, and yet there was the air of tension after Mr. McHugh shouted to them, the stark ugliness of one of the men pulling out a gun.

"You bums!" Mr. McHugh was shouting. The high glass candy showcase hin-

dered Davie's view now. Only the sounds came to him. He heard the cash register key ring, then the crash of glasses and again Mr. McHugh's voice: "You bums! Stop that! No—no you don't—"

Davie sat rock-still. The shot of the gun rang out awfully loud, and continued to ring in the sudden silence.

"I had to," Davie heard the words. "He was holding onto me! I had to!"

"Let's get out of here."

His eyes still fixed on the mirror, Davie saw a brown tweed jacket as it darted out into the night.

Davie was scared, clear through. The entire action had transpired in but a few swift seconds. Without wondering why he was doing it, Davie Vernon ran out the back door into the alley. The darkness closed in on him and for an instant he realized he was in a panic. As he ran toward the street he had time to think and reproach himself for the way he'd bolted out of Mr. McHugh's place—so unlike Wyatt Earp or Wild Bill Hickok, so cowardly.

Only vaguely was he aware of the importance of his presence in the store, only vaguely thinking that his description of the brown tweed jacket might help the police.

**D**AVIE slowed his run as he came out on the side street. He tried to tell himself that he wasn't running away from the shooting. All he was trying to do was keep out of trouble. After all, he was only eighteen, almost. The best thing he could do right now was get home.

He started to cross the street, still goaded by his thought to walk around to the front of the store, and find out how Mr. McHugh was, but in that instant he saw two men walking hastily toward him. Davie went on across the street. One of the men wore a brown tweed jacket, the other—and Davie now took time to look—wore a blue suit. One of them, Davie knew, had fired the gun in Mr. McHugh's soda parlor. They were now getting into a car, and Davie took his time to see it as a '39 repainted gray coupe with a badly-ripped rear left fender. As the car sped away Davie tried to note the license number but couldn't.

This was no illusion, no daydream. This was for real. What hurt Davie deeply was the way he'd reacted when danger struck. He sensed a peculiar resentment, a near disgust with himself. Gone was whatever bravado of a western gunfighter he'd ever pretended, gone was even the desire to return to the store and tell the police whatever he could. All he wanted was to get home. . . .

"I thought I told you to be in the house by nine-thirty," Davie's father said to him the moment he came through the door.

"Dad, I think—" Davie said, his voice weak, "I think I saw a killing. I—I got to tell you about it . . . it happened . . ."

For a long time neither his father nor his mother spoke. Like parents, they momentarily thought of the newspaper stories,

the stomp-killings, rowdies on the loose, teen-age gang wars, with their son somehow mixed up in it. Mr. Vernon slowly let go of the paper he was reading, and asked: "Just what kind of killing did you see?"

Davie blurted out his story. He told it quickly. "I think—I think, Mom," he turned to face his mother, "they killed Mr. McHugh."

Davie's mother wept. She put her arms around him, and Davie couldn't quite understand when she said over and over, "But you had nothing to do with it—you had nothing to do with it, Davie." There was a certain joy in his mother's voice, which wasn't for Davie to understand. His father slumped back in a relieved way, and then fumbled for a cigaret. "Davie, don't ever," his father said, "scare us like that."

Davie stood awkwardly now, shifting his weight, finding his own hands in the way. "Will you call the cops, Dad?" he asked hoarsely.

"The cops?" his father said after him. "Well, I don't—" He got up and walked around, trying to put life into his legs. Davie's mother sat down on the couch and began wiping her eyes.

"If Mr. McHugh is hurt," Davie said, "I mean hurt real bad, or—or if he's dead—then—"

"Now wait a minute," his father said. "I don't want you mixed up in anything like this."

"But I could tell the cops I saw the shooting. I could tell them I saw the car."

"I don't want you mixed up in anything," Davie's father said again. "I'm sure the police will be able to handle it. This can be very bad, and you know it. I don't want you mixed up in it, Davie."

The decision not to telephone the police was perhaps a typical one for Davie's father and mother. The reasoning was simple and direct, from their point of view—to keep Davie out of trouble. Surely someone else beside their boy had seen the killers escaping, if they were killers.

But the decision didn't set well with Davie. Perhaps because he was still engrossed in his self-disgust, having revealed himself not the equal of even the poorest gunfighter he'd read about, or perhaps because of his age, he nevertheless seemed unable to evaluate the intricate shades of his feelings. But what he did know was for sure—he wasn't brave, and neither were his parents.

The following day the newspapers told of the murder of Mr. McHugh. The police had nothing to go on, the papers said. Billy McHugh's empty seat was a mute reminder of tragedy everytime Davie looked there. When Eileen tried to tell Davie she had had to help her mother with curtains the night before, he told her to leave him alone.

"Gee, what's with you, Davie?"

It all amounted to a simple reaction, of which Davie was hardly aware. In his

**WHAT A DREAMBOAT!  
MY IDEAL HERO!**

**WHAT A DATE!  
I'M BATTING ZERO!**

**SMELLS GRAND!  
PACKS RIGHT!  
SMOKES SWEET!  
CAN'T BITE!**

**WHY YOU  
SMOKE A PIPE  
TOO! M-M-M!  
YOU'RE FOR  
ME!**

**IT'S  
SIR WALTER  
RALEIGH—  
NATURALLY!**

**SIR WALTER RALEIGH'S  
BLEND OF CHOICE KENTUCKY  
BURLEYS IS EXTRA-AGED TO  
GUARD AGAINST TONGUE BITE.**

**FREE!**  
24-PAGE BOOKLET  
ON PIPE CARE.  
JUST WRITE TO:  
SIR WALTER  
RALEIGH,  
DEPT. 196-D  
LOUISVILLE, KY.

daydreams he had shaped himself into a reckless, daring, bold gunfighter. He had never expected to witness a killing, true, he'd been safe in his make-believe world of Wyatt Earp and Wild Bill Hickok and the rest, making up dangerous situations with himself always the fastest on the draw. Never was he in real danger, and now this was stark reality and he'd realized the vast difference. He was not cut out for a brave showing. He was nothing. A coward. And what hurt all the more was knowing his father and mother were cowards.

In other words, Davie Vernon had unveiled himself. He wasn't good enough to polish the boots for a man like Earp or Hickok. . . .

**I**T WAS FOUR EVENINGS LATER when Davie was to meet Eileen in front of the pet shop on the avenue, not far from the now-closed soda parlor. He'd never told her or anyone else that he'd been there that fateful night. But soon his chance was to come . . .

As Davie waited, cars sped by, now and then one with twin tail pipes roaring and making him tremble a little. The '39 coupe of the killers had had twin exhausts. Davie felt he'd hear that sound the rest of his life.

Dungaree clad and wearing a red jacket, Eileen showed up behind Davie and poked him in fun. "Hi, wha-cha lookin' at? Wow! Look at the longface." She giggled. "Where're we going? Are Squatts and Dolly meeting us?"

Davie wasn't talkative, nor in the mood for kidding. "Squatts and Dolly went to see a movie," he said.

"Then treat me to a vanilla malted," Eileen suggested as they walked along. "Say, what's with you anyway?"

"Nothing."

She tried to interest him in some school rumors, her doings at home, and plans about college, all to no avail. "Hey!" she exclaimed as they passed the second soda fountain. "Aren't we?"

"Aren't we what?" Davie asked absently.

"Going to have a soda or ice cream or something." Eileen had come to a halt and was looking at Davie in a tolerant way. "You're a couple of days removed," she chided him.

"Let's go up to Tully's," Davie said.

"Okay, but what's wrong with right here?" She didn't expect an answer, so they started walking again up the avenue. Tully's was farther up where the kids usually went for hamburgers. It was exactly in the opposite direction from the main business district.

There were no crowds up this way, nothing to remind Davie of Mr. McHugh's place. Davie was not in a position to analyze his actions, much less understand that he was in every way avoiding the place which had showed him up for what he was. If only his father had telephoned the police, if only his— Davie tried to suppress his thoughts, his shame.

## BATON TWIRLING CONTEST SPONSORED

Chairman C. P. Hebenstreit of the Grand Lodge Youth Activities Committee and Chairman Arthur J. Roy of the Grand Lodge Committee on Lodge Activities have endorsed the National Baton Twirling Contest being sponsored by Binghamton, N. Y., Lodge, No. 852, and urge other lodges to sponsor entrants in the competition to be held July 13th in Binghamton.

J. W. Sheehan, Chairman of the Contest Committee, announced that trophies will be awarded to first-place winners in girls' senior, junior and juvenile classes, in boys' senior and junior classes, and to winners of an Open competition. Entries must be made through Elks lodges, and further information may be secured from Chairman Sheehan, P. O. Box 269, Binghamton.

He was in this state of mind, then, walking along with Eileen, when he saw the parked gray '39 coupe with its badly-ripped rear left fender.

Recognition shook Davie down to his heels. His heart pounded uncontrollably, but he said the words that fitted his age.

"Gee, gosh!"

"What, Davie?" Eileen asked as she too stopped to glance across the street.

"Gee, gosh," Davie said again. "That's their car!"

Eileen naturally latched on to a parked Cadillac. "Someday," she said confidently, "you'll have one too. Let's go."

**B**UT Davie was suddenly in another world, not entirely a make-believe world of western gunfighters and motion picture screen heroes, for now, this instant, with time in which to gather himself into a force, with time to realize that he was no more cowardly than any other youngster his age. Davie knew exactly what he could do to avenge the killing of Mr. McHugh. It wasn't something that Earp or Doc Holliday would have done, no, it was what Davie Vernon could do.

"Davie!" Eileen cried out. She wasn't expecting him to grab her wrist so hard and pull her into a house doorway. "What're you doing, Davie?"

"See that car," Davie began. "Listen—listen good now." It was the way Gary Cooper would have spoken, in a drawl, but hard and tough. "Do you remember what happened to Mr. McHugh"—and then Davie for the first time told Eileen his story.

"Davie, I'm scared. I'm not as brave as you. Oh, Davie."

Davie spoke quietly to her, holding both her hands in his. He asked her to

get hold of herself, and to run down toward the business section of the avenue and there get a cop. "Tell 'em what I told you! Tell 'em to hurry back here!"

"What'll you do, Davie?"

"I'll keep my eye on their car. Now hurry!"

"Oh, Davie . . . Davie . . . I'm scared."

"Okay, so you're scared. Now hurry up, will you!"

After Eileen left, Davie, under normal circumstances, might have done what he said. Keep his eye on the car. And when the police arrived he could have them safely take over. But reading about fine deeds of Earp and his kind, seeing Cooper and Wayne and Peck portraying even greater actions, Davie couldn't very well just wait it out.

Farther up the avenue he saw the lone lighted sign: *Bar & Grill*. Davie walked the distance, his stride big, as if he wore high-heeled boots, his arms limp at his sides and palms open, as if he'd suddenly be forced to whip out his Colt and open fire.

Davie, of course, possessed no Colt. This part, one might say, was still part of his teen-age imagination; he was, quite subconsciously, in the satisfying role of a western sheriff, and he was going to have a look-see for himself yonder at the saloon. Eileen's words still rang in his ears and gave him a peculiar sense of power and courage. "I'm not as brave as you, Davie," she'd said, and she'd meant it.

The interior of the bar appeared awfully dark, menacing, outright forbidding. Far in the rear, as in Mr. McHugh's place, were tables and benches set apart as booths. Davie could see couples talking over drinks in what seemed to him a natural manner. Davie turned around and retraced his steps, again looking in, this time at the men standing at the bar.

Davie couldn't mistake that brown tweed jacket, the shoulders and the back of the neck. And drinking alongside his pal, stood the other killer, wearing the same blue suit which Davie recalled.

Davie felt his heart pound faster, all the way up into his ears. He squinted down the avenue to see if Eileen was coming up with a policeman. Eileen was always late. Davie peered over the car tops, hoping Eileen had come upon a police prowler car. The only thing in sight far down by the **fourth traffic light was the** bus, a truck, several yellow taxicabs and private cars. No police car.

Davie turned his attention back to the men at the bar. His imagination told him he'd have no trouble fighting those two men. No, he wouldn't be so foolish to listen to his imagination. Yet the illusion of Earp and Hickok nudged him, pushing him to action. He crossed the street several times, went down to their parked car, all the while fighting off temptation that would cause him to take a foolish step. He got back to the bar. The only thing he could do, he admitted, was enroll the help of others inside the place. And he had to do it now, for he saw brown jacket



toss money to the bartender and then button up in a move to leave.

Davie trembled a little as he grabbed the door handle, squeezed the catch, and pushed the door in. He'd made his move. There was no backing down now. His knees felt weak, unwilling to support him. The scowl tossed his way by the bartender almost sent Davie outside.

"What d'ya want, kid?" the bartender called to him.

But—the way he'd seen Gregory Peck stand his ground—Davie kept on with what he had to do.

The two men, both young and not very much older than Davie, turned to look at him. So did others there at the bar. Davie's legs turned limp; he was suddenly afraid and thought he could still get out of there.

But he didn't. He lifted his left arm and pointed his finger straight at the two men before him.

"They're killers!" Davie shouted.

**H**E SAW the two men stiffen and exchange glances quickly, but they made no wrong moves. Some of the others in there had turned to look, and were smiling at the sight of Davie pointing accusingly. Brown jacket gave a little laugh, and said "Clown" so everybody could hear.

"I saw you!" Davie shouted. "I saw one of you kill Mr. McHugh!" Davie turned to face the others at the bar. "I swear! Somebody grab them! They're killers!"

Nobody moved. Here was the peculiar power of accusation, a boy pointing and shouting, and yet no one dared take a chance. Someone or other may have sensed Davie was telling the truth, but the same caution that had held Davie's father in check held these men. Why take a chance? Why stick *my* neck out?

Perhaps what saved Davie was the fact that the two killers couldn't afford to take a chance either. Panic urged them to action, a panic which showed in their young faces and in their wild eyes. Davie saw it, understood it. The realization struck him that these two men were just as scared now as he'd been when he saw them in Mr. McHugh's place.

"Cowards!" Davie shouted. "Yaaa! Look at them! They're scared! Cowards! Somebody grab them! Somebody—"

Even for scared men, the one in the blue suit hit awfully hard. The fist sank deep into Davie's stomach, sent him against the far wall with a sickened feeling. Davie was watching both men reach the door at the same time, and still no one in the crowd had moved to help.

"Grab them!" Davie shouted again, struggling to his feet.

It is difficult for two men to go through the same door at the same time. Brown jacket had fumbled, and the door had slapped back at him. For a moment he was caught there, pushing the door the wrong way, desperately trying to reach the street and take flight after his pal toward their parked car.

Anger more than anything else carried

There goes that call again...  
that friendly, cheerful call again

Hey Mabel...  
**Black Label**



The premium beer at the popular price

Have you tried Carling Black Label Beer? It's a pleasure to drink... and it's priced for your pleasure, too. Next time you buy, give Black Label a try.

The best brews in the world come from CARLING

CARLING BREWING CO., Cleveland, Ohio, Belleville, Illinois, Frankenmuth, Mich., Natick, Mass.

## Wear the Mark of a Superior Man



**\$4** POST PAID

For N.Y. City purchases add 11 cents city sales tax.

Wherever you go your official Elks pin is recognized as an honored and respected symbol of a superior man who has been chosen by superior men of his community. It's an emblem that is proudly worn by thousands of your Brother members. Do you wear one? If not, why not get yours by sending the coupon below with just \$4. The pin is enduringly enameled red, white and blue on a 10kt gold plated base and is

truly a handsome jewel. Order your pin today. It comes to you insured.

Illustrated folder sent on request.

THE ELKS MAGAZINE,  
386 Fourth Avenue, New York 16, N. Y.

(Please indicate)  
check  
money order  
cash

Send me pin 7-e described above. Enclosed is \$4.00

Send to.....  
Street.....  
City.....

(Check, cash or money order must accompany order.)

Davie in a flying tackle headlong for the doorway. All he could do was scoop his arms and grab brown jacket around the knees.

With this much happening before their eyes, several men at last parted from the bar and rushed in to give Davie a hand. Brown jacket kicked and struggled, his shoe grazing Davie's ear hard enough to bring blood. Davie felt nothing in the way of pain, not now anymore; he heard a car starter whirring and whirring and whirring, unable to start the motor of the '39 coupe—

The police prowling car screamed to a stop, parking at an angle. Eileen was there, jumping and getting in the way of everybody. Davie saw a sedan pull up, and suddenly there were a couple of detectives holding the crowd back, uniformed police asking questions, excitement, excitement.

One of the detectives was asking Davie now if he was the one who'd seen the men in Mr. McHugh's soda parlor, and Davie was telling him the whole story while the detective was trying to slow him down and get it in proper order.

The detective was grinning. He then took Davie's name and address. "You look all in, kid—you ought to be at home."

"Okay, folks," one of the policemen was saying loudly. "That's all now."

Eileen was hanging onto Davie's arm, chirping excitedly at him, none of which penetrated. Davie's gaze was fastened on the detective, and he now went over to him and handed him a small object. "I took it out," Davie said to the detective.

The other grinned again. "So that's why the punk couldn't get his car started. Thanks, kid. We'll be around to talk to you, sometime tomorrow. You better go on home now."

When Davie and Eileen walked away, the detective said to his sidekick: "These kids pick up all sorts of gimmicks from the movies. The kid"—he held up his open palm for the other to see—"took the distributor cam out of their car."

"That's the movies for you," the other detective said.

Eileen hurried her way, eager to reach home and the telephone so she could spread her version of the story. Davie, on the other hand, was taking his time, walking with big steps, letting his imaginary Colt slap against his thigh, walking lightly in his high-heeled boots, which proved harder pretending due to his low-heeled loafers.

Davie was his old self again. He was on edge, true, but that was something to be expected after what he'd been through.

## GRAND LODGE CONVENTION INFORMATION

### Ritualistic Contest

Chairman Edward W. McCabe of the Grand Lodge Ritualistic Committee asks that applications for entries in the National Ritualistic Contest to be held in San Francisco, Calif., during the period of July 14th through the 18th should be filed with him promptly, as State winners are determined at P. O. Box 202, Nashville, Tenn.

A revised judges' training sheet has been printed and copies may be obtained from the office of the Grand Secretary.

### Exhibits and Displays

As Chairman of Exhibits and Displays for the Grand Lodge Convention, J. Edward Stahl of the Grand Lodge State Associations Committee has notified all State Presidents that the Grand Lodge Convention Committee has selected the Civic Auditorium in San Francisco for these displays, and has arranged with the J. L. Stuart Co. of that city for materials, etc.

The Committee will assign space for State exhibits in the order in which they are received. Upon receipt of request for space, the Committee will forward that information to the J. L. Stuart Co. which in turn will contact the Association direct, making all necessary arrangements. Expenses for shipping, handling, booth equipment and so on will be assumed by each State.

With his letter, Mr. Stahl included a form, a "Booth Display" and rate sheet which are to be filled in and returned to him as promptly as possible, so that the needs of each State Association will be known.

The change came over him as he realized he was nearing home. The change was visible, inasmuch as Davie had slowed down and had shoved aside his thoughts of Wyatt Earp, played by Davie Vernon a few moments before. What Davie thought of now was his father and mother—yes, they'd like what he'd have to tell them, but . . . but they were still his father and mother who had been afraid

to telephone the police that first night.

This was on Davie's mind when he reached home, and this was what made him hang his head upon entering the front room where his father and mother were waiting for him.

"Aren't you late coming home again, Davie?" his father asked.

Davie wanted to tell him what had happened, he wanted to tell it real badly, but somehow the kick of it was gone. All he could say was "Yes, Dad."

Davie's mother saw the blood on her son's ear and neck. "Look at you!" she said, visibly holding herself in check. "Where were you? What were you doing? Davie . . ."

"We can go into that later," Davie's father said flatly. "Sit down, Davie—we want to have a talk with you right now."

Davie sat on the edge of the chair and waited for his father to begin.

"Davie, your mother and I have given this a great deal of thought. We want you to understand the importance of right and wrong. Davie, are you listening to what I'm saying?"

"Yes, Dad."

"As I was saying, then, everybody should know what's right and what's wrong. Now we feel, your mother and I, that we did the wrong thing not telephoning the police about the McHugh thing, we—well, let's say we made an error."

Now Davie sat upright, expectantly watching his parents, waiting.

"If we," his father went on, "permit ourselves one error and don't give it any thought, we might end up making other errors and not thinking anything about it. Now, as I said, we gave this a lot of thought, Davie. What we did was to telephone the police. We told them you were at Mr. McHugh's place when he was killed. The police are sending a detective over here, he'll be here any minute. Now your job will be to tell him everything."

For a brief moment Davie stood there silently, and then tears came to his eyes, tears which he didn't try to suppress. He rushed forward and grabbed his father, which was something Davie hadn't done in a long time. After all, Davie was going on eighteen now.

Davie's father then did the only thing he felt appropriate under the circumstances. He folded his arms protectively over his son and, turning to Davie's mother, said there was no need for everybody crying and carrying on like that.

"Come on, now—that detective'll be here any minute."

"Okay, Dad," Davie said.

## The Heedless Horsemen

(Continued from page 11)

zling questions. Why do animals venture onto roads at all? Why are casualties so heavy on some nights and light on others? Why are September and February the bad months? Why are certain stretches of the road, and even certain spots, so deadly?

One reason animals frequent roads is for the warmth. On bitter nights following an afternoon of sunshine, roads are considerably warmer than the air or ground, and this linger of warmth is sometimes noticeable as late as midnight. Black-top

roads may be as much as twenty degrees warmer than the natural terrain. Our small friends like to stand on registers too, and they have four feet that get cold.

Rainy darkness is always a bad-casualty time for creatures of the night. Ordinarily,

animals prefer to travel in cover of some sort, but in rain-drenched grass or brush their fur gets soggy, cold, heavy; so they take to the roadway to get relief from this constant sopiness.

Exactly as children do, young animals resort to the smooth, level surface of roads for their play—those games that are amazingly like tag or hide-and-seek. Young rabbits will spend hours at their intricate, fascinating play maneuvers. The peak of young-animal activity comes in late summer, and this is why September is a month of heavy toll.

When uncrusted snow lies deep over the fields and woods—and just a few inches is belly-deep for small animals—the snow-plowed roadways naturally afford much easier going, sometimes the only going. The late-winter period of heavy snows coincides with the mating season of most small animals and also with the time when their food is scantiest and they often are only a jump or two ahead of starvation. During this period they travel far and wide, as their snow tracks show. This combination of circumstances is why February is the worst month of the year on the record sheet.

In the wildlife scheme of things this late-winter destruction is doubly serious, because creatures killed then have a high strategic importance. They are the individuals which have survived the various vicissitudes of the preceding seasons, and the new crop depends on them. A rabbit killed in February is as bad a loss as half a dozen killed in August.

Other reasons for their frequenting roads are: dust baths, to keep down parasites; food scraps thoughtlessly tossed out of cars (what a thoroughly bad business that is!); and those chain casualties where a creature will linger around a mate or litter mate which has been killed. This habit, a sort of primitive wake, is very strong with rabbits and raccoons.

Simple crossings, however, account for the majority of times that animals venture onto highways. All animals do a good deal of traveling on trails that are ancient footpaths of their tribe. These paths may have been in use for dozens of generations. In fact, some bear trails in the West are known to be a thousand years old. Deer crossings are of course familiar to everybody, but the smaller creatures are just as habituated to their ancestral paths. The deadly spots which show up so clearly on a record sheet are places where these trails cut across a highway. Or maybe it's the highway that cuts across these immemorial trails.

But whatever their reasons, the fact remains that animals do frequent roads, and we must take this fact into account. Some people don't. One evening I saw a man callously run down and kill two young raccoons and when I later asked him if that had been necessary, he made the stupid reply: "Then tell 'em to stay off the roads! They don't pay taxes, do they?" When fate, a couple of years later, touched him on the shoulder one night and gave

him the one-way ticket, it was no accident but a direct consequence of his unrealistic attitude.

No, animals don't pay taxes, but they pay a heavy price just the same. My statement about the "tens of millions" of wildlife victims was no exaggeration but colder fact. Every road is a toll road for wild creatures and the price they pay is not a few dimes but death.

**Y**OU sometimes hear it said that in the course of time the wildlife in the territory along a road gets killed off and that's the end of the loss. The trouble with this idea is that it isn't so. Go out and take a drive on some long-established road and you'll see it isn't so. The highway leading past my house was a pike that Washington's men used, and it's been hard-topped for a couple of generations—and it's the worst road in these parts for casualties. Animals don't stay put. Foxes will shift their home range as much as fifty miles in a month, as studies have shown. In spring and fall deer travel extensively. Coyotes will move clear across a state in a year. Gray squirrels migrate en masse to better areas. My own studies of the woodchuck show that even this stolid, home-loving citizen will pack his suitcase and depart for greener pastures.

The truth is that when an area along a road gets depopulated, other animals from farther back move into it, and they in turn get killed off.

This wildlife destruction has come on little by little and so has gone unnoticed by the general public, but in many sections conservation officials, whose business it is to know about such things, now rate the automobile as the Number One destroyer of small game animals and fur-bearers in their territory. In a south-central Ozark region that I knew well, I remarked to a senior game warden that the wildlife around there seemed to be definitely less abundant than what I remembered, and his reply was fairly typical of what conservation people are thinking: "It's these new highways and the big increase in cars. They're killing more coons, rabbits, possums, skunks, groundhogs and what have you than our hunters, trappers and natural predators combined. The only way to realize this is to go out and make actual counts, and then figure that this is happening every hour of the day and night on every mile of road in the land."

He was so right. Actual counts and studies are the only way we ever realize the full toll that the automobile is taking. Otherwise we grossly underestimate. For example, I have asked men who live on the "Back Road" across the valley, "How many animals, do you think, get killed on this road in a year?" The usual answer is, "Oh, a few dozen." Let's look at my study of that road:

This is a six-mile stretch of secondary leading along the flank of the valley. It is not much traveled at night, about seven

## Father's Day Special! Since 1926! The Halvorfold

Loose-leaf Pass Case, Billfold, Card Case. Note exclusive features. Read Special Offer below

**\$5.00** Black or brown Morocco **\$7.50** Smooth black or brown Calfskin  
Now with or without emboss. ELK emblem outside front

**"Made to Order" for ELKS**

**Free Examination! Send No Money—Pay No C.O.D.**

Means exactly what it says. No strings. Mail coupon. Halvorfold comes by return mail. Examine it carefully. Slip in passes and cards. See how handy it is. Show it to your friends and note their admiration. Compare it with other cases at more money. I trust Elks and all the Mrs. Elks, who buy annually, as square-shooters. And I am so sure the Halvorfold is just what you need that I am making you the fairest offer I know how. Send coupon NOW. Avoid last minute rush!

**FREE** in 23K Gold, Name, Address and any Emblem. Would ordinarily cost \$2.50 extra. Ideal Gift with friend's name and any fraternal emblem.

**HALVORSEN, P.C.M.—700 E. Union Street  
Jacksonville, Florida—Dept. 81**

Send HALVORFOLDS as per instructions below. If I decide to keep them, I will send check at once. If not, I will return merchandise in three (3) days. (HALVORFOLD comes regularly for 8 passes. For 12-pass add .25c. 16-pass .50c, etc. Please check squares at right.)

**PLEASE CHECK HERE:**

Black Calfskin  Brown Calfskin  
 Black Morocco  Brown Morocco  
 Gold Filled Snap & Corners \$1.50 extra  
 8-pass  12-pass  16-pass  
 Elks Emblem Embossed Outside  Yes  No

Name:..... 23K Gold Inside Emblem:.....  
Please Print

Address:.....

5% off to save bookkeeping, if you prefer to send cash with order. Money back if not satisfied.

cars per hour from dusk to dawn, and the adjacent territory is about average in regard to wildlife abundance. With the help of two friends who traveled it regularly, one at midnight, the other at sun-up, I was able to get fairly reliable figures on the night-time casualties there through the course of a year. Not counting the day casualties, which probably were not heavy, or the unknown number of creatures that were wounded and crept off into the brush to die, or the casualties removed by scavengers, that road killed .27 animal per mile per night, or 1.62 animals per night for the six-mile stretch.

This innocent-looking figure of .27 animal per night-mile works out to nearly *six hundred creatures a year!* And this is only recorded casualties. There were many others, as indicated above. The real total was probably close to nine hundred—which is considerably different from “a few dozen.”

Let me emphasize that this Back Road is neither exceptionally good nor bad; it's somewhere near average for the country around here. Some local roads are plainly worse, as my data shows, and some are better. My sampling figures for other states and sections—Florida, the Midwest, Colorado and an area around Edmonton—are too scanty for more than a mention, but they suggest higher figures than here.

This .27 animal per night-mile may seem small, but when we start applying it to areas it begins growing like the *jinii* out of the bottle. When I applied it to the roads of this township, for instance, I saw beyond any question that the automobile does kill more game and furbearers, far more, than all the local hunters and trappers. When we apply the figure to a county, the yearly total climbs into six figures. When we multiply this by the three thousand counties of the land, the total gets astronomical, and we begin to see why conservation people regard this incessant, mounting drain on our wildlife resources as the worst recent development in their field.

As surely as tomorrow's sunrise, this vast national network of new, fast roads is going to mean grief, not only on account of the wildlife destruction but also the human casualties, unless this problem is studied out beforehand and vigorous steps taken.

**B**EFORE going on that night drive, it might be well for us to dispose of the day casualties, which don't make up a very large part of the total and which concern mostly woodchucks, squirrels, young rabbits and those venerable woods tortoises which go slow-poking across the highway on summer days.

When we see a creature on the road ahead, we should never try to avoid it by swinging over to the left of the line, as some people do. This is a dangerous habit to form and can lead to a bad-type collision with another car. Rather than swing out, we should allow the casualty to happen, regrettable though that may be. But in most instances we have time to slow down

and let the animal get safely off the road.

The trouble is that so many drivers don't slow. It isn't that they don't care or are bad drivers essentially. They will slow for other reasons, such as the standard highway rules and courtesies, or the directions given in driver manuals, but not for animals on the road. The explanation, I would say, is that they haven't been told what to do in this case and they don't exercise very much imagination. However, more and more drivers *are* slowing to avoid these casualties, and maybe in time those less alert individuals will get the idea that it's the proper thing to do.

Now for that night drive. You've run over animals and you don't like it. You've had a narrow escape or two from bad deer accidents and know that injury or death can be waiting in the buckrush at almost any deer crossing. So you want to pick my brains. All right, let's go.

Suppose it's a rainy night in late October, and we're driving along that Back Road, with the wooded hill range on our right, some dairy farms and swamp areas on our left. For the purposes of our trip we push along as fast as is safe on a road

## Tribute to Aidmore

While The Elks Magazine does not make a practice of running poems because it would obviously be unfair to select a few of the many received for special attention, we recently noticed a poem that appeared in “The Spirit of 78”, bulletin of Atlanta, Ga., Lodge, written by Mrs. Kermit Carr, who is Vice President of the Elks Aidmore Auxiliary. Aidmore is known throughout Elkdom for the great work it is doing to help crippled children lead happier lives. While space does not permit using Mrs. Carr's entire poem, because of its association with Aidmore we here reprint it in part.

*My legs were crooked—born that way;  
I couldn't move around,  
I'd never stood or walked.  
Sometimes I'd crawl upon the ground.  
They called it “act of providence,”  
Which has to be endured.  
Anyway, the neighbor said,  
Such cases can't be cured.*

*The Elks' doctor saw my legs.  
He didn't shake his head,  
Like most folk do. “We'll fix you up  
As good as new,” he said.  
“We're awful poor,” said Ma,  
“It's hard to pay for food and rent.”  
“Give us that Boy,” the Elks said,  
“It won't cost you a cent!”*

*I don't know how they did it;  
I'm not much on Doctor's talk;  
I only know I used to crawl—  
And now! See, I can walk!  
I wonder why mother cried when  
I went home, not crawling anymore,  
But through her tears I heard her say,  
“God bless the Elks and Aidmore.”*

that is wet and full of curves. It's ten o'clock and not many cars are abroad. The night is velvety black, the air rain-sweet and heavy with the smell of damp woods and autumn leaves, and the animal eyes here and there along the way are like different-colored jewels. Most of the cars we do encounter are hitting it up faster than we, and we wonder why they don't take it a little safer, a little easier, and enjoy an hour when it's a pleasure to be outdoors.

Several hundred feet ahead we pick up a pair of eyes on the right side of the road. The blue twinkle tells us it's a raccoon, and it's crouching there a minute or two to make sure the coast is clear before it starts across. All animals do this. When they come to a road, or any other open stretch, they instinctively stop, look, listen and monitor the air with their nose. If we know about this habit of caution, we can use it to keep them from coming on out and getting run over.

“Watch,” I say. With a simple little maneuver, while we're still two hundred feet away, I drive the raccoon back from the road, back into the brush, and we go harmlessly past.

A few hundred yards farther on we spot a pair of eyes, burning amethyst in color, in a cornel thicket on the left side of the road. It's a fox. Probably it's been mousing in a swamp near by and is returning to its lay-up in the hills. “I'll make him cross the road,” I say, shifting my lights a little. Sure enough, the fox flashes across the road and up a grassy hillside, with that airy, graceful flight that live foxes have but dead, run-over foxes don't.

This time you catch on that my control over the actions of those animals is somehow connected with shifting my lights, but you don't yet know exactly how it works. So we tootle along till I find what I've been hoping for—a rabbit sitting in the middle of the road. I slow down to a dog trot and glide up quietly. The rabbit starts to hop off the road to the left. I shift lights in that direction, and it veers back to the center again. Then it tries to hop off to the right, but I shift that way and it turns back to the white line.

After several attempts to break free, it gets philosophic about the matter and goes hopping down the road ahead of us.

This harmless little stunt, which anybody can go out and repeat, illustrates the simple rule back of controlling animal actions along the highway. An animal goes the opposite direction from our light shift. If we shift to the left, it goes right, and vice versa. A very slight shift, a very small turn on the steering wheel, is all that is necessary or advisable. We don't have to swing out to the mid-line or over onto the shoulder. A swing of a few inches is multiplied into many feet by the projected shaft of light. It's the light beam, not the car itself, that influences the creature.

All animals that I know of respond to this light shift. Out in the Gunnison River Valley one night a friend and I drove a

**PGER WALKER APPOINTED  
TO SERVICE COMMISSION**

Past Grand Exalted Ruler John L. Walker of Roanoke, Va., Lodge, has accepted an appointment by Grand Exalted Ruler Fred L. Bohn to the membership of the Elks National Service Commission.

jackrabbit along for seven miles, and we might still be driving it except that we came to the outskirts of Gunnison and a dog got into the act.

Every few yards, as we drive our cotton-tail along, he gives a funny little leap straight up in the air. This is a "spy hop"—to see what on earth that huge enemy is that's purring along behind him. We smile at this amusing, jack-out-of-the-box leap. But deer, too, have this spy hop habit, and sometimes their hop is a little on the grim side. A deer that is blinded by a speeding, on-rushing car will often give one or more of those up-and-down bounces just before it gets hit, and when that happens it comes slamming back over the engine hood and through the windshield. After one of these accidents the driver will often state that the deer he hit was acting crazy.

We don't want to drive our cooperative rabbit out of his home territory, so we shoo him over into a field and watch him go streaking back toward where we picked him up, and you remark that he'll surely have something to tell the boys back yonder. I remark that if a fast car had come along instead of us, he wouldn't be alive to tell anybody anything.

Around the next bend a tongue of woods reaches down to the road, and there we spot seven deer, standing in the roadside brush like dun ghosts and reconnoitering. Nearly every night a number of deer come down through that strip of timber, a typical deer crossing, and pasture on the succulent swamp-edge grass on the other side. In the past three years that spot has been the scene of at least two deer-car collisions, one of them plenty bad. Probably there were other collisions that were kept quiet. Most states have laws requiring deer accidents to be reported, because some individuals actually go *hunting* deer with old, banged-up automobiles. But as often as not, especially on back roads, people will just stick the deer in their car and take it home, figuring that the hundred pounds of venison will make up in

**WILLIAM BYRON MOWERY**

As we were about to go to press on this issue, we learned that William Byron Mowery passed away at Warwick, N. Y. on April 2nd after an illness of several months. Mr. Mowery's nature stories and articles have been an editorial highlight of The Elks Magazine for several years, and it was with sincere regret that we received notice of the death of this distinguished author who so thoroughly understood, and deeply loved, our American wildlife.



**More . . . and more . . . and more  
ECHO SPRING answers the call  
for truly smooth  
Kentucky Straight Bourbon**

No finer bourbon ever came out of Kentucky. And yet Echo Spring comes to you at a price lower than most other Kentucky Bourbons. For a truly smooth bourbon call for Echo Spring again...and again...and again.

STRAIGHT BOURBON WHISKEY...86 PROOF...ECHO SPRING DISTILLING COMPANY, LOUISVILLE, KY.

**Do You Own  
or Manage  
a Store?**

If so you can help your Elks Magazine if you'll fill out and return the coupon below. It strengthens our story when we solicit advertising from manufacturers who sell through dealers to be able to state how many Elks there are who sell their products. The return of the coupon in no way obligates you and will materially assist us in our efforts to secure more advertising for THE ELKS MAGAZINE.

**THE ELKS MAGAZINE**

386 4th Avenue, New York 16, N. Y.

MY NAME IS \_\_\_\_\_

ADDRESS \_\_\_\_\_

CITY \_\_\_\_\_ STATE \_\_\_\_\_

TYPE OF BUSINESS \_\_\_\_\_

(PLEASE CHECK BELOW)

I OWN THIS STORE

I AM PART OWNER OF THIS STORE

I DO NOT OWN, BUT MANAGE THE STORE

## NATIONAL MASS MEDIA AWARDS PROGRAM OF THE THOMAS ALVA EDISON FOUNDATION

With the support of sixty-two national organizations, including the BPOE, the Thomas Alva Edison Foundation in 1955 established its National Mass Media Awards Program to interest boys and girls in science and engineering careers. In keeping with the traditions and guiding principles of its namesake, the Thomas Alva Edison Foundation is concerned with encouraging mass media to realize their potential for constructive influence on the nation's youth. The Foundation, after considerable evaluation, concluded that only in the area of children's books was a good job being done to make science seem attractive and important to American youth. This is particularly unfortunate, in view of the critical shortage of trained manpower that the United States currently faces, for an adequate supply of scientists and technicians is essential to our country's peace-time program and national security.

The purpose of the Edison Foundation Awards Program is to encourage mass media industries to take up the challenge in such a way that young people will be stimulated to want to know more about the world they live in, and, as a result, engage in science careers.

The 1956 Edison Foundation awards have just been announced as follows: Best film, "On the Threshold of Space" (Twentieth Century-Fox); best radio program, "Adventures in Science" (CBS); best children's book, "Exploring the Universe" (Garden City Books). No award was given this year in the television field, because of the scarcity of science materials on network TV.

part for the damage to lights and fenders.

After a deer accident the driver will often say, quite sincerely: "It just suddenly appeared out of nowhere. I don't understand where on earth it came from." Well, deer don't jump out of nowhere and they don't materialize out of thin air. In many instances the animal was standing near the road reconnoitering, and the reason the driver didn't see it was that he had "bumper vision." He was staring fixedly at the road in front of his car, instead of constantly shifting his gaze from side to side, near to far. Bumper vision, or "road hypnosis," is bad enough in the daytime. At night it's a wide-open invitation for trouble. I don't know of a better way to stave off bumper vision than by watching ahead for animals, identifying them by the color of their eyes and shooing them in the direction we want them to go.

You and I both picked up those deer when we were a good four hundred feet away. We agree that there's no excuse whatever for hitting a deer at that place. Bumper vision or excessive speed or both were the explanation of the accidents which had occurred there.

The seven deer staring at us from the brush are flicking their ears nervously and trying to make up their collective mind what to do. I shift my lights to the left. Almost with one motion the seven turn in their tracks and drift back from the road. As we go by we see a big buck a rod or so from the highway, covering the retreat;

the others are easing on back among the trees.

Except for those rare occasions when deer are being chased by dogs or are otherwise frightened or confused, they will almost invariably stop near the road edge and reconnoiter, before crossing, and if we are alert we can see them. A band of reconnoitering deer will always respond to this light shift. Sometimes they will turn silently and disappear back into the woods. Occasionally they will merely "freeze" and stand quiet till we are past.

But if we go barreling down at them, blinding them with our lights and maybe adding to their bewilderment with a blare from the horn (Great day, a deer doesn't know that a horn blast means to stay off the road!), there is never any predicting what they'll do. Sometimes they go crashing back into the woods, in the direction they came from. Sometimes they break up as a group and go glancing off every which way. Sometimes they all come piling out onto the road.

A mile farther on we pick up a big doe ahead, apparently alone. She crosses the road, leaps the fence and trots down across a little field. You watch her and remark, "That's one we don't have to worry about." I shake my head and say, "You're wrong about that." I am already slowing down and watching sharp—not watching the doe but the scatter of woods to our right. "This is the most dangerous kind of a deer set-up. It could be that she's alone, but

the chances are that she's leading a file of deer across the road and down to that swamp."

Deer traveling in file are usually led by a doe and often they are widely spaced, as much as a hundred yards apart. Those behind have a strong, sheeplike instinct to follow the leader, willynilly, and that's where the trouble comes in. The driver will be watching that front deer, already across, and suddenly—bang-o!—another deer leaps in front of his headlights or comes whanging into the side of the car. The rule to follow here is this: when we see one deer, we should automatically assume there are others around. We should slow down as much as possible, stop watching that front animal and keep a sharp lookout for those others.

In our granddaddy's time, railroad engineers were told that when they saw buffalo, deer or elk on the tracks they should switch off their headlight and give a gentle toot or so with the whistle. With deer on the highway it used to be good driving procedure to stop, dim the car lights and let the deer all get across. On little-used roads in rural areas that is still the safest way to handle this deer-in-file situation. But don't try it, don't even think of trying it, on our fast modern roads. A stop is more dangerous than a deer collision. One of those highway idiots who ride our taillights will come smashing into us if we stop. Or any driver hitting it up at the allowable speed may fail to see us in time to avoid a crash.

No, we don't dare stop on a fast road. The best we can do is a compromise: slow down as much as is safe; lower our lights; watch for those animals following the leader. Usually this compromise is good enough; it will take us safely through that file of deer. It's the procedure that you and I use, and it takes us through that line of dun ghosts with a good margin of safety.

**WE COME TO THE END OF THE BACK ROAD** and as we swing home you read off our record sheet and we talk about our drive. The rain had put an unusual number of animals on the road—raccoons, foxes, rabbits, deer at three places, skunks, possums, even a muskrat—and the other cars had taken a heavy toll, eight casualties. And if a fast car had

### CARDS NEEDED AT THE HOME

David B. Whitehead, Chairman of the Recreation Committee at the Elks National Home, Bedford, Virginia, advises that there are thirty or forty residents at the Home who like to play cards and that the supply is low. Lodges or individuals having used cards available are requested to forward them to the Home and are assured by Brother Whitehead that they will be most appreciated.

happened to pass that tongue of woods or the deer-file crossing, we might have found an automobile overturned in a ditch or wrapped around a tree.

We ourselves, not dawdling but driving at a good speed, were at no time in any danger of a deer accident, we ran over no creature, we didn't even have a near miss.

It doesn't, of course, always work out this neatly. In spite of knowing about the light tricks and animal ways at night, a person will still have the occasional accident. But we can cut the number of these down tremendously. For whatever it's worth, I myself have run over just two animals in the last five years, a rabbit and a muskrat, and I do a lot of night driving.

And, of course, people who insist on driving too fast for the conditions of the road won't find very much help in these suggestions of mine. They are so busy playing Russian roulette with the road hazards that they don't have time to look for animal eyes or deer or anything else.

Take that drive of mine mentioned at the beginning. It was thirty miles of hill-and-dale road, sheeted with ice at places, with snow crawl at others, and through country where deer were plentiful. The majority of the drivers were taking it at a safe, sensible speed, but there were half a dozen cars that went zipping past, doing most of that wildlife slaughtering and risking their own crack-up. I doubt if a single one of those fast cars had any valid reason for being so hellbent on getting wherever they were going.

Besides the danger, they missed so

much. They missed all the rare, sparkling beauty of the country and the night. Some of those scenes from the hilltops, out across the dark-silvered, sleeping valleys, were unforgettably pretty. Yet those cars never slowed, lingered, looked. They went whizzing along as though the few minutes they saved were worth gambling their lives for.

Or take that winter night and the chap I found at the stone bridge. When he went past me, doing his fifty on a winding, rain-wet road, I thought I recognized him but wasn't sure till a little later. I remember thinking that sometime or other his luck was going to run out, if he was the person I thought, but I hadn't any suspicion, as he vanished around a curve, that matters were closing in on him even then. I was very wrong.

When I saw the wreck ahead, I pulled to one side and hurried up to the bridge, with a flashlight. Over in the brush I heard a thrashing sound and thought it might be the man, stumbling around groggily, and I stepped into the thicket. But it was the doe he had hit, bone-broken and dying. At the car I took a look through the shattered window and saw the driver. One look was enough.

As I walked back to my car, to drive on in and report the accident, I noticed that my headlights were playing on a big, prominent sign, "Deer Crossing." He certainly had seen that sign but evidently had paid no attention to it. I wondered if he had thought, as he once remarked to me: "Tell 'em to stay off the roads! They don't pay taxes, do they?"

## In the Doghouse

(Continued from page 33)

across the country. They are that traditional among fire fighters. I'm quite sure that many so kept still respond when the alarm sounds. In a town not far from where I live, one of the stations has Smoky—seems they're always given that name—a dog that promptly hops on the truck as soon as he hears the town's fire siren and hasn't missed a call in all the seven years of his duty.

But don't get the idea that the Dalmatian is a purely ornamental adjunct to the fire department. Time and again newspaper accounts have appeared showing the dog having rendered active assistance at the scene of a fire. They've guided firemen in finding persons trapped in buildings, have helped in rescue work, and not a few have been injured through falls, burns or by inhaling suffocating smoke. Yes, there are many four-footed heroes attached to our firehouses throughout the nation. Some have learned to climb ladders, and there's even a record of one dog that rescued a cat. Some years ago, the dog Mike, attached to Engine 8 in New York City, was accorded the privilege of having his own railway pass, this being given to him for heroic services rendered. The pass was engraved on a silver plate fastened to his collar and, believe it or not,

it was honored by the road which issued it.

Shortly after the automobile became popular, the Dalmatian went into a decline in public favor. He had been so thoroughly identified with the horse that with the passing of the latter animal the general idea seemed to be that the Dalmatian's usefulness had drawn to a close. It was overlooked for the time being that the Dal was still not only a handsome dog but one of convenient family size and a fine, sagacious, canine companion. When I mention family size, I mean that he can readily adapt himself to a city apartment and, being easy to keep clean, presents few problems to a busy housewife.

He's one of the few dogs whose color changes with age. Puppies of the breed are born all white. They acquire the black or brown spots as they grow older. Another peculiarity is that when whelped their tails are curved, but in the weeks following they straighten. Despite his clean, somewhat racy lines he's a powerful dog built for endurance. He had to be to survive the many weary miles of roadwork he was required to perform as a coach dog. While he's a friendly fellow, he isn't given to overdoing the hospitality business. He has the reserve that marks good breeding and is more likely to try to withdraw from

## IMAGINE ME EARNING \$15,000!

By a Wall Street Journal  
Subscriber

I remember when I was earning \$100 a week. I felt good about it. I dreamed that some day I might earn \$10,000 a year. But it seemed remote.

Then came the flood of rising prices and rising taxes. I had to do something to keep my head above water. One thing I did was to subscribe to The Wall Street Journal. It was a life preserver! It told me things to do to win advancement, to protect my interests and to increase my income. Last year I hit a new high. Just the other day I said to my wife, "Imagine me earning \$15,000!"

This story is typical. The Journal is a wonderful aid to men making \$7,000 to \$20,000 a year. To assure speedy delivery to you anywhere in the U.S., The Journal is printed daily in five cities—New York, Washington, Chicago, Dallas and San Francisco.

The Wall Street Journal has the largest staff of writers on business and finance. It costs \$20 a year, but in order to acquaint you with The Journal, we make this offer: You can get a Trial Subscription for 3 months for \$6. Just send this ad with check for \$6. Or tell us to bill you. Address: The Wall Street Journal, 44 Broad St., New York 4, N. Y. EM-5

THE  
**adjustable**  
ALL-IN-ONE GOLF CLUB

Does everything a set will do...  
It's so EASY and THRIFTY to  
PLAY BETTER—beginners or experts.  
Try it—money back guarantee—\$24.95

International Golf Co. HINSDALE 56, ILL.

## Law!

**STUDY AT HOME**

We guide you step by step—furnish all text material, including 14-volume Law Library. Training prepared by leading law professors and given by members of the bar. Degree of LL.B. Low cost, easy terms. Send for valuable Free Book, "Law Training for Leadership," today.

LaSalle Extension University, Dept. 5328L  
A Correspondence Institution Chicago 5, Ill.

## ELKS BASEBALL UNIFORM



Fully approved for Elks sponsored Junior League teams. These uniforms feature:

- Fine Crickett T flannel
- Professional cut
- Beautiful and expert lettering
- Complete washability
- Substantial Savings for your Lodge

Adds prestige to your program and will delight the kids you sponsor.

Write for complete information and prices.

**RUSSELL-HAMPTON COMPANY**

303 West Monroe Street Chicago 6, Illinois



**monroe**  
**FOLDING**  
**BANQUET**  
**TABLES**

Direct Prices & Discounts to Clubs, Churches, Lodges, Schools and All Organizations

COMPLETE CATALOG ON REQUEST



**MONROE TRUCKS**

For handling and storing folding tables and chairs. The easy, modern way. Choice of models.



**PORTABLE PARTITIONS**

Change your idle space into useful areas with these Partitions. Masonite panels in tubular steel frames with swivel action pedestals and casters or glides.



**FOLDING CHAIRS**

Steel built, sturdy, convenient.

**THE Monroe COMPANY**  
90 Church St. Colfax, Iowa

**BOOK MANUSCRIPTS**  
**CONSIDERED**

by cooperative publisher who offers authors early publication, higher royalty, national distribution, and beautifully designed books. All subjects welcomed. Write, or send your manuscript directly.

**GREENWICH BOOK PUBLISHERS**  
Attn. Mr. Essex 489 Fifth Avenue  
New York 17, N. Y.

**BEST DEAL FOR THE MAN AT THE WHEEL**  
**HULL AUTO COMPASS**

While passengers enjoy scenery, the driver has to watch directions—unless he has a Hull to show the way, constantly, accurately. Driving is a pleasure with Hull, world's most widely used auto compass. \$4.95 and \$6.50. At your dealer's or write for literature.

**A Favorite Boating Accessory, too!**



**HULL MANUFACTURING CO., P. O. BOX 246-EE4, WARREN, O.**

**WANTED \$50**  
**FOR INVESTMENT**

IN AN IMPORT-MAIL ORDER BUSINESS PLAN that you can operate at home in spare or full time. **BIG PROFITS** possible for men and women. Travel opportunities, too. No previous experience required. Write today for details about **FREE ADS** and how to get mail orders without investment in stock while offer is still open to **IMPORT-EXPORT, Dept. G395**

1717 Westwood, Los Angeles 24, Calif.



**Everlasting Bronze**  
**BOOK OF MEMORY**

For listing 100 to 3000 names economically. Write for free catalog including photos of hand-chased cast bronze plaques.

**NEWMAN BROTHERS, Inc.**  
Dept. 722, Cincinnati 3, Ohio

## If Your Child Is a Poor Reader

See how The Sound Way To Easy Reading can help him to read and spell better in a few weeks. New home-tutoring course *drills* your child in phonics with records and cards. Easy to use. University tests and parents' reports show children gain up to *full year's grade* in reading skill in 6 weeks. Write for free illustrated folder and low price. **Bremner-Davis Phonics, Dept. J-19, Wilmette, Ill.**

overfamiliar handling than to resent same. I've never seen a quarrelsome Dalmatian and I've seen some few in my time, but like most dogs his size, he can give a pretty good account of himself if he has to go to war on his own. While this is not intended as a knock against certain other breeds, a nice thing about Mr. Dalmatian is that he doesn't have to be clipped, cropped, docked or altered in any way to suit the whims of fashion. He's all dog, looks like a dog should—nothing freakish about him—and comes to his owner just the way Nature made him. His coat should be short, hard and fine, never silky or ragged. When he's groomed, which isn't necessary very often, a brisk polishing with a soft cloth upon which a few drops of olive or mineral oil have been sprinkled, will make him sparkle, deepen

the color on him and help make the white more brilliant.

I've found that, being an intelligent dog, he's not very hard to housebreak. In truth, he learns to be a gentleman around the house sooner than many other dogs. The standard for his breed states that he should be between 19 and 20 inches high at the shoulder (where dogs are always measured for height). His weight should be between 35 and 50 pounds. These requirements are for both sexes.

For spectacular appearance, the only other dog approaching the Dalmatian's coloration is the harlequin Great Dane. But then he's a giant, albeit a gentle giant, and if you have room for him, a fine quiet and powerful guardian to have around. He, too, is a black and white speckled dog, a variety of the Dane family.

## Rod and Gun

(Continued from page 17)

were marketed commercially. The whole idea seemed sort of silly to me. Besides, I always was busy with some outdoor activity, anyway. This was true even in the winter when I have to budget my spare time between crow hunting and steelhead or whitefish fishing. Nevertheless, I finally succumbed. Herb Carlson and Clare Conley and some of the other fellows I know bought them, and they reported good luck in calling bobcats and coyotes up to within shootable distance.

My first attempts at calling were not very successful so far as furred predators were concerned, but I soon learned one interesting thing: If there is a magpie within hearing distance when you blow the call he will come—right now. If there are a dozen, or 40, they will all come. If you sit perfectly motionless, they will often light almost within arm's reach.

I suppose magpies, being primarily scavengers, hope to pick up the scraps left by whatever caught the rabbit. Regardless of their reason for coming, it is perfectly all right with me. I like to shoot magpies, and this is the only method of calling them I have ever found.

Hawks occasionally come to the call. So do dogs hunting on their own and stray house cats. Coons sometimes come. So, very likely, would a weasel, marten, cougar, or bear if you happened to blow the call within his hearing and under the right circumstances. I have no doubt that it would be deadly on lynx in the North, since their diet consists primarily of snowshoe hares, although I have never heard of anybody's trying it there. I have blown the call while watching deer dozens of times. They invariably threw up their heads and looked. Sometimes they resumed feeding and sometimes they ran as though the devil were after them, even though I may have been 400 yards away and downwind.

The entire subject of calls and calling is a fascinating one, and I suspect that man's attempts to lure various birds and animals by this means extend far back

beyond the dawn of recorded history. I have heard Eskimo children imitate perfectly the calls of many of the birds that spend their summers in the North. American sportsmen use a surprising variety of calls. In fact, when I stop to total them up, the Trueblood family itself has quite a bunch.

In a box downstairs there are two elk bugles, two duck calls, one goose call, one coyote call, three crow calls, and one Audubon bird call. The last is strictly my wife's idea and is not used with evil intent upon our little feathered friends. It is surprisingly effective, however, in getting them to reveal themselves to be looked at. In addition, we both call quail without the aid of any mechanical device.

We use all of our calls and whistle quail more or less regularly. If we lived in the South I'd certainly have a turkey call of one kind or another, and maybe a squirrel call. If we lived in the North we'd probably have a moose call. In some areas bucks are called by rattling their antlers, and there are several mechanical deer calls on the market. In fact, I had one once, but the boys were so fascinated by the noise it made that they worried it to pieces before I ever had a chance to try it.

The various calls function in different ways. An elk bugle, for example, issues the challenge of a bull elk in rutting season, and the bulls that come to it are looking for a fight, while a moose call imitates a cow that is interested in looking for a boy friend.

The most widely used duck calls imitate the invitation of a female mallard to join her for food, rest or a social visit. On the other hand, the most effective crow calling in the summer consists of reproducing the pleading of a young crow in distress. In the winter your crow call may say, "Come on over boys, I've found the grub," or, more likely, be an excited invitation to join a battle against some mutual enemy, such as a hawk or owl.

Most calls, of course, imitate the voice



of the species we are attempting to call. Maybe that's why it was so long before somebody thought of the now-popular predator call. It makes no attempt to sound like any of them, but instead issues the distress screams of the animal upon which they all prey, the rabbit.

Some birds and animals are easy to call; others are difficult. Also, as we have all observed, the success of our calling may vary widely from day to day. Undoubtedly there is a wide variation in the way sounds carry under different atmospheric conditions and in different surroundings.

In my opinion, all of the scavengers and predators are easier to call than game birds or animals. This, I think, is because they generally are more intelligent, strange though that may seem. Curiosity is a mark of intelligence, and crows and magpies, coyotes, bobcats and foxes all are curious to a marked degree. All of them are likely to investigate, albeit with caution, anything out of the ordinary that they happen to see or hear.

Their reaction when they discover that they have been duped sometimes is ludicrous. I didn't give the first coyote I called a chance to learn his error. I shot him before he saw me, and he never knew what happened. The second one, however, is still, to the best of my knowledge, hunting mice and rabbits.

**I** **CROSSED A RIDGE**, traveling upwind, and just under the crest I sat down with my back against a clump of bitterbrush. I started "squeaking," as I call it, and continued for about 15 minutes. Then, concluding that there was nothing within hearing except the four magpies and a Stellar jay, which had already come and gone, I started to move on. I had walked only a few yards, however, when I saw a coyote break out of the timber across the valley. He was fully 250 yards away, but he was coming straight toward me in a fast lope.

I quickly sat down again and resumed squeaking. He had a steep hill about 100 yards long to climb, but he got there much sooner than I thought he could. In fact, I barely had time to draw my gun, cock it and lay it across my lap when I saw him. He was 27 yards away, downwind. Instead of coming straight to me he had run up the hill a little to one side—possibly to determine whether something bigger than he had the rabbit.

Apparently, he both smelled and saw

me at the same time, just as he stopped with head and shoulders showing above some rabbit brush. You should have seen his face! He made me think of a hungry man sitting down before a big steak—on a wired chair and getting a terrific shock.

I didn't even attempt to shoot him. Instead, I laughed out loud. He jumped and turned and seemed to run for several seconds in the same spot, but in a few seconds more he had disappeared around the hill.

His surprise undoubtedly was slight, however, compared to that of a bobcat I once called up. Rob Donley and I, cougar hunting along the Middle Fork of the Salmon River, in Idaho, had walked up Little Loon Creek to the forks. There we took our packs off and sat down on a log. Rob's two hounds were trotting around nearby.

I got my call out and started to squeak. Not more than three or four minutes later, a bobcat came up over the bank, about 30 yards away. Holding my squeaker in one hand, I continued to call while I tried to fumble my gun out of my pack with the other. Meanwhile, I whispered to Rob to sit still.

Just as I got the .38 clear, one of the dogs trotted past about halfway between us and the cat. It crouched in indecision. There was some brush in front of it and I hated to shoot for fear a twig would deflect the bullet, but I decided it probably never would come any closer after seeing the hound, and it could jump down behind the bank out of sight. I shot, and missed.

Immediately, we both jumped up. Rob called the dogs and put them on its trail, and they gave it a hard run for about a mile until it finally plunged into a maze of cracks and crevices among a jumble of boulders at the base of a cliff.

After giving up, we built a fire on the spot of bare ground underneath a tree and sat down to enjoy a pot of tea. While the amber brew was steeping, Rob said, "I'll bet that's one bobcat that's wondering what in the hell has come over the rabbits around here. He hears one in trouble and comes to help it out, and look what happens. First, it shot at him. Then it hollered and yelled and sicked the dogs on him. Then he had to run for his life. I'll bet he spreads the word to stay away from rabbits in distress!"

Maybe he did, too. We stayed in that area about a week longer, but I never did squeak up another cat!

## Young Tigers in a Hurry

(Continued from page 8)

the All-Star "break" in July the Yankees had a handsome 53-25 won-lost record which gave them an 18-game bulge on the wobbly Tigers, who were cozily entrenched in fifth place. From July through September the Yanks won 44, lost 32; Detroit had a 48-30 record, a flag-winning pace. Unfortunately, for Detroit, the American League doesn't operate on a split season,

but the fast finish, plus Detroit's 12-10 season's edge on the Yankees, gave the Tiger fans ideas about the 1957 campaign.

No less important is the fourth reason—the appointment of Jack Tighe as manager. The fact that Tighe is an old catcher is taken as a good omen by Detroit partisans of sound memory. They remember Mickey Cochrane, Del Baker and Steve

## Fishin'-Fun for Everyone

WITH  
**PUSH-BUTTON  
Magic!**



Shakespeare  
**PUSH-BUTTON  
WONDERCAST**

A push of the button—s-w-i-s-h of the rod—PRESTO—you're Push-Button Fishing. Bait casting AND spinning advantages. Ask your dealer about machined gears, smooth drag, non-reverse crank, rugged construction—other outstanding features. No. 1775 with line, \$19.95

Send for 5 new fishing booklets — FREE  
**SHAKESPEARE COMPANY**

KALAMAZOO,  
MICHIGAN

**GREATEST NAME  
IN RODS  
REELS — LINES**

### ADDRESS LABELS \$1 1000 PERSONAL

Up to 4 lines handily printed with your name and address in black on gold-bordered gummed paper (1/2 x 1 3/4 in.). PLASTIC BOX INCLUDED. Save time. Protect possessions. Use on envelopes, checks, parcels, books, records, tools, toys, etc. SPECIAL SPRING OFFER 1000 for \$1 ppd. ANY 5 ORDERS \$1. Guaranteed to please. Write Bruce Bolind, 50 Bolind Bldg., Montrose 47, Calif.



### CHANGING YOUR ADDRESS?

If your plans for the next few months include a change in your address, please give us advance notice for our circulation records. We need your old address, your new address and your Lodge affiliation. Please allow thirty days for the change to be effected on our mailing list. Notice of the change should also be sent to your Lodge Secretary.

THE ELKS MAGAZINE

## BE YOUR OWN BOSS

Earn \$7,500.00 to  
\$15,000.00  
a Year



### OWN A **tastee-freez** STORE

Join America's most exciting and fastest growing chain of soft ice cream DRIVE-INS. Enjoy good income, permanent security. TASTEE-FREEZ Stores are individually owned, nationally advertised and merchandised. Over 1,800 stores coast-to-coast. Locations available throughout U.S. and Canada. Minimum capital \$3500. (Higher in Metropolitan areas and Canada.) Information FREE. Write: Tastee-Freez, 2518 Montrose, Dept. D-57, Chicago 18, Ill.



**MEN! Make up to \$1,000 IN A MONTH!**

**without "SELLING"**

**Sensational Demand for Low-Priced Fire Alarm PLUS Sure-Fire "No-Selling" Plan Offers Ambitious Men Huge Profit Opportunities**



Even beginners cleaning up unbelievable profits with first practical, effective, low-priced Fire Alarm. Needed in homes, factories, offices, stores, on farms, etc. Merlite Fire Alarm hangs on wall like a picture... no wiring, no installation. It's always on guard, "smells" fire before danger point. When temperature rises, Fire Alarm goes off automatically, howls loud warning that can be heard 1/5 mile, wakes up soundest sleeper, gives precious time to put out fire, call fire department, or escape. Sells for only \$4.95, with profit up to \$2.70 on each one.

**Nearest Thing to Automation Selling**

With our field-tested plan customers sell themselves. No cold canvassing; no hard selling. It's the nearest thing to "Automation Selling". Even a child can use plan successfully with powerful sales tools we give you (which you leave with prospects). This plan makes money for you even while you sleep! No room here to give you full details, but write for amazing facts.

**FREE SALES KIT!**

Send no money. Just rush your name and address for all the exciting money-making facts, complete Illustrated Sales Kit, everything you need to make money first day. Learn how selling only 20 Fire Alarms a day brings you \$1,080.00 a month. No competition. Get in on ground floor now. Rush your name and address—that's all.

**DRAMATIC LIGHTED-MATCH DEMONSTRATION**  
Sensitive! Lighted match triggers Alarm in 3 seconds!

**MERLITE INDUSTRIES, INC. (Alarm Div.)**  
114 E. 32nd St., Dept. S-4W, New York 16, N. Y.  
In Canada: Mopa Co., Ltd., 371 Dowd St., Montreal 1, P. Q.



**SAVE \$7.20 on NORELCO MEN'S ELECTRIC SHAVER...**

Latest model, brand new and fully guaranteed. Complete with case, cord and cleaning brush. Regularly retails at \$24.95. Our price \$17.75 postage paid. All orders filled within 24 hours. money back if you are not fully satisfied. Send check or money order to:

**JOHN BROOKS, Dept. 457, Box 212, St. Louis 3, Mo.**

**NOW... Enjoy at HOME**  
**"The BEST STEAKS you ever ate"**



**famous pfaelzer FILET MIGNON**

Shipped DIRECT TO YOU...  
"Blast Frozen"—ready for your freezer.  
Perfect arrival GUARANTEED...  
delivery anywhere in the 48 states!

These Pfaelzer beef tenderloin steaks of U.S. Prime quality are tender, flavorful, mellow-aged... have been served for over 30 years by exclusive clubs, fine hotels and restaurants... now are preferred in many better homes, everywhere! They're sure to enhance your personal and family's enjoyment... delight your guests when you entertain. These Steaks can't be purchased in any store. Introduce yourself to extraordinary dining pleasure. Take advantage of Pfaelzer's TRIAL OFFER today! Send check or money order. Receipt acknowledged by return mail.

**Introductory Offer!**  
LIMITED TIME ONLY  
**16 FILET MIGNONS**  
Approx. 1 1/4" Thick **\$29.50** per box  
5 or more boxes \$27.50 ea.  
R. R. EXPRESS PREPAID

Over a hundred freezer delicacies—steaks, chops, roasts, etc. to delight the discriminating diner, now available through unique Pfaelzer Home Service. Ask for free, 20 page illustrated catalog.

**Pfaelzer Brothers, Inc.**

Dept. EL-5 • Union Stock Yards • Chicago 9, Ill.

O'Neill, each of whom learned his baseball behind the plate. Cochrane led the Tigers to pennants in 1934-35, Baker was the flag-winning pilot in 1940, O'Neill in 1945.

Tighe succeeded Stanley (Bucky) Harris, a big league manager for 28 of the last 33 years who had the stamp of being an easy-going leader. The new owners quickly declared themselves for a manager with "spirit and aggressiveness."

"When I read that in the papers I knew I wouldn't be back," said Harris, without rancor. Famed as Washington's "boy wonder" manager of 1924, Harris is a quiet, genteel type, seldom involved in squabbles with the umpires, seldom critical of his hired hands, seldom given to public displays of temper. This was easily translated into complacency—a bum rap, but the men who put up the record-breaking pile of cash felt a managerial change might be the very thing for the Tigers, who undeniably have the nucleus of a great team.

Tighe, who was one of Harris' coaches last season, said of the 1956 team: "We should have finished in the first division." Harris, however, had no apologies. He pointed out that Harvey Kuenn, the short-stop with the solid bat, was hurt early in the season; Frank Lary, the 21-game winner, got off to a miserable start and so did the brilliant Al Kaline.

Harris, now a special assistant to General Manager Joe Cronin of the Boston Red Sox, assays the 1957 Tigers in this manner:

"Detroit needs a first baseman, another starting pitcher, a catcher and an outfielder," obviously a large bill of goods in one year, or even two. Harris insists there is no catcher on the Tiger payroll capable of providing the hitting and leadership a flag winner needs.

As the Tigers wound up spring drills in Florida it was entirely possible that the

first base problem had been solved. "If Ray Boone (a converted third baseman) can't do the job," Tighe told the writer, "I'll put him back on third and use Ed Robinson and Earl Torgesen. If Boone can adjust to the job, I'll put Jim Finigan on third base." Robinson, acquired from Kansas City, is a sluggish 37, but he gives the Tigers a dangerous left-handed pinch-hitter and reliable reserve.

"I'd really like to use Kuenn at third," Tighe confided, "but I haven't got a short-stop." Kuenn, of course, is a standout big leaguer at 26; if he has a weakness it is in being a bit slow as the middle man on the double play. But Kuenn and young Frank Bolling give the Tigers much better than average coverage through the middle.

Manager Tighe will rely on Bob (Red) Wilson, a former football star at Wisconsin, and Frank (Pig) House, the \$75,000 bonus baby of 1948, to give him adequate catching. He can hardly expect more. House and Wilson hit a total of 17 home runs last season.

Kaline, of course, is the Detroit star of stars; he easily ranks next to Mickey Mantle in the American League's current roll call of heroes. Kaline is just as important to Detroit as Mantle is to the Yankees, if not more so. A batting champ at 20 in 1955, Kaline had 128 runs-batted-in in 1956, only two less than Mantle. Kaline and Kuenn supplied the one-two punch that tortured rival pitchers last September when the Tigers won 20 of 27 games. Unexpected help came, too, from Charlie Maxwell, an ex-Boston bench-ridder who suddenly blossomed at 30. Maxwell hit .326, collected 28 home runs and 87 RBI's. All of which leaves Bill Tuttle as the real worry of the outfield. He had a horrible time of it in 1956, sliding from .279 to .253 but the Tiger brass feels certain this 28-year-old will do much better this summer. If he doesn't he will be in the dugout watching 20-year-old Jim

**HISTORIES MEMORIALIZE AINSWORTH ELKS**



Ainsworth, Neb., Lodge honored the memory of two of its deceased members not long ago when copies of the "History of the Order" were presented to two local libraries in the names of the late George F. Kent and Charles A. Richardson, Sr., E.R. Dr. V. L. Hybl, Est. Lead. Knight Glenn Richardson and P.E.R. C. E. Burdick, Neb. Elks Assn. 2nd Vice-Pres. and Chairman of the Assn.'s Elks National Foundation Committee, made both presentations. The Alder Public Library ceremony is pictured here, with Mrs. Grace Weiss, librarian, accepting the gift. At the Ainsworth High School Library, Mrs. Alice Ross received the book as librarian.

Small, who batted .319 in 91 at-bats last season, roam the outfield.

It is entirely within the realm of possibility that the infield, outfield and catching can be good enough, Harris notwithstanding, but Skipper Tighe must find a fourth starting pitcher if the Tigers are to leapfrog the Indians, White Sox and Red Sox. Three young fellows came with a rush last season—Billy Hoelt, 25; Frank Lary, 26, and Paul Foytack, 27; they won 56 of Detroit's 82 victories and there is no apparent reason why they can't do as well or better. Tighe can count on Steve Gromek, the "old man" of the staff, for 10 victories or so, mostly before the mid-season sun wilts him; otherwise, the accent is on youth. Off-season trades sent Virgil Trucks and Ned Garver to Kansas City, which means reinforcements must come from untried youngsters.

All through the pre-season exhibitions Tighe put the pressure on Duane Maas, 26-year-old speedballer; Jim Bunning, 25, who has been up twice before; Hal Woodeschick, 24, who had a 12-5 record in triple-A play, and Don Lee, 23-year-old southpaw who learned to pitch from his dad, Thornton Lee, ex-White Sox star.

"I expect one of those four to be my fourth starter," Tighe said. "The job is there for the man who can win it."

Tighe is also taking a long look at Larry Donovan, a 23-year-old righthander up from Buffalo; Joe Presko, an ex-Cardinal; Bob Miller, a bonus signee from Chicago who is only 21; and Al Aber, the 30-year-old southpaw who headed the bullpen corps a year ago.

The pitching is not impressive, on paper, once you get beyond Lary (21-13), Hoelt (20-14) and Foytack (15-13), but when you consider the strange case of Lary you know anything can happen even in big league baseball. Lary won more games than any pitcher in the league, yet there were times when Harris had a great urge to send him back to his native Alabama.

"We had no pitching depth," recalled Harris. "Otherwise, Frank would have been in the bullpen. I didn't have anyone who could do better, so I just kept pitching him. His big fault was in getting behind the hitters."

"But Frank has the heart. The way he was pitching in September he could win 25 or 30 just as well as 21. Frank never gives up on a batter. The best hitter may have him 3-and-0 with the bases loaded but Frank will be trying on every pitch. You know, around Detroit they compare him to Tommy Bridges (great curve baller of the 30's), but Frank might be even better than Bridges in a few years."

Lary had a messy 4-10 record in early July, a 17-3 record the rest of the way and he defeated the Yankees five times. Much has been written about Lary and his knuckler, possibly too much if you listen to some of Lary's victims.

"The knuckler didn't have much to do with Lary's good record," said a rival manager. "Oh, it helped some but the fact

remains that Lary had excellent equipment all the time—a fine curve, sneaky fast ball, slider and exceptional fight. He began winning when he quit getting behind the hitters."

Lary should be the bell cow of this hastily-rebuilt Detroit team. Like Mantle, Herb Score and many others, Lary was prepared for stardom from the time he was a grammar school boy. Once you get behind his veneer of reticence you discover that Lary comes from a colorful tribe of Alabama Larys. He is one of six brothers who learned the rudiments of baseball from their father, J. M. (Mr. Mitt) Lary.

At their home in Northport—five miles from the University of Alabama campus—there was, and still is, a pitcher's mound and home plate in the front yard. Mr. Mitt would sit in a rocker on the front porch and coach his sons in the art of pitching. The Larys lived for sports and music. All of them can play two or three musical instruments, including the fiddle, or violin; two brothers starred in football at Alabama. Frank and Gene, the baby of the family, bypassed football for baseball. Gene won 19 games for Mobile last season, earning a full-scale tryout this spring with the Cleveland Indians. He appears headed for the baseball jackpot just like Frank.

**T**HUS, ANY ANALYSIS of the Tigers reveals as tremendous assets three strong pitchers, a great shortstop, a brilliant outfielder, youth all over the place and a front office that demands action. Tighe could be the man to drive the young fellows, cajole their elders and get the maximum out of all hands. He has done it before in the long pull—four years as a non-hitting bush leaguer, 12 years as a minor league manager, one year as a scout, three years as a Detroit coach.

Heeding Jack Zeller's advice in 1940. Tighe got a Class D managerial assignment that same season. He is a veteran of the bus and baloney circuit, managing at Muskegon, Mich., Winston-Salem, N. C., Batavia, N. Y., Flint, Mich., Toledo and Buffalo.

After getting the Detroit job last October Tighe put in a long distance call for his mother in New Jersey.

"Hello, Mom," he said. "This is Jack. I got the job."

"That's fine, son; how much will you make?"

"About \$5,000 less than Stengel," he quipped, referring to Casey's new contract for about \$75,000.

"Son, don't ask for too much; they might give the job to somebody else. You've waited too long for this chance to let it slip now."

Tighe is a chunky type, only 5-9; he has small, penetrating eyes and the jutting jaw that indicates the tenacious fighter he is. He talks easily and frankly with the newspapermen. He'll be good copy, but he knows when to use the muffler. There was the time late in 1953 when Tighe,

## Become an ACCOUNTANT-Auditor—C. P. A.

The demand for skilled accountants—men who really know their business—is increasing. National and state legislation is requiring of business much more in the way of Auditing, Cost Accounting, Business Law, and Income Tax Procedure. Men who prove their qualifications in this important field are promoted to responsible executive positions.

### SEND FOR FREE BOOK

Knowledge of bookkeeping unnecessary. We train you from ground up, or according to your individual needs. Low cost; easy terms.

Send name and address on the lines below for free illustrated book describing the LaSalle Accounting training and the opportunities in this highly profitable field.

**LASALLE EXTENSION UNIVERSITY**  
*A Correspondence Institution*  
417 S. Dearborn St., Dept. 5328H, Chicago 5, Ill.

Name.....  
Address.....  
City..... Zone..... State.....

## REAL ESTATE BE A BROKER

**PAYS BIG!** SEND FOR FREE, BIG, ILLUSTRATED CATALOG NOW! Graduates report making substantial incomes. Start and run your own business quickly. Men, women of all ages, learn easily. Course covers Sales, Property Management, Appraising, Loans, Mortgages, and related subjects. **STUDY AT HOME** or in classrooms in leading cities. Diploma awarded. Write TODAY for free book! No obligation. Approved for World War II and Korean Veterans.  
**WEAVER SCHOOL OF REAL ESTATE** (Est. 1936)  
2020H Grand Avenue Kansas City, Mo.

**FREE BOOK TELLS HOW**

## FREE—U. S. STAMPS

U. S. 1943 Bi-Colored Flag of Occupied Nations (as illustrated) Airmails, Commemoratives, Regular Issues, included in this collection of 25 selected, all different, genuine U. S. Stamps. **PLUS VALUABLE U. S. \$5.00 STAMP.** Everything for 10c to cover mailing expenses. Approvals included. (returnable) Act at once.  
WILLET CO. P. O. Box 390 Dept. 24, Mount Kisco, N. Y.



## LAW FREE BOOK THE LAW TRAINED MAN

Write today for a FREE copy of illustrated law book, "THE LAW-TRAINED MAN," which shows how to earn the professional Bachelor of Laws (LL.B.) degree through home study of the famous Blackstone Law Course. All necessary books and lessons provided. Moderate cost; convenient terms. Write for FREE law training book today.  
**Blackstone School of Law, 225 N. Michigan Ave.**  
Founded 1890 Dept. 115, Chicago 1, Ill.

## MAGIC IS FUN! MAKE MAGIC YOUR HOBBY! CHANGE NICKELS INTO DIMES!

Place MAGIC CAP over 4 nickels. Presto! Nickels vanish and 4 dimes appear! Cap may be examined. No skill required! Precision-made device. **ONLY \$1.00 POSTPAID.** Please remit with order. Satisfaction Guaranteed.  
FREE! WITH YOUR ORDER  
LARGE CATALOG OF 500 Amateur and Professional Magic Tricks. WRITE TODAY!  
D. ROBBINS & CO., New York D-393  
127 W. 17 St. New York 11, N. Y.



## Elks! FOR ALL MEMORABLE OCCASIONS BRONZE PLAQUES

Say it better . . . Say it forever . . . Say it for less  
U. S. Bronze leadership in quality and artistry is forever impressing everybody everywhere, and low prices keep our customers pleased, too. Write now for new complete FREE color catalog and information—helpful suggestions for honor rolls, awards, memorials, testimonials, for everything. Write to

"Bronze Tables Headquarters"  
**UNITED STATES BRONZE SIGN CO., Inc.**  
570 Broadway, Dept. E, N. Y. 12, N. Y.

then the manager at Buffalo, fell out with Joe Ziegler, the general manager. Jack was on the verge of resigning with a big blast at Ziegler. One of the Detroit scouts advised against it. Jack accepted the counsel and thereby saved his future with the parent club.

Tighe can be pretty rough on umpires, too. In that same season of 1953 he had an historic run-in with Max Felerski of the International League. Tighe was accused of spitting in Felerski's face, a charge serious enough to put him out of baseball. Buffalo friends rushed to offer him legal assistance. Tighe refused it. Instead, he offered to take a lie detector test, never before or since used to settle a baseball argument.

"Unless I'm cleared that's the end of me in baseball," says Tighe. The Buffalo police department ran the test on Tighe's veracity. He was absolved. President Frank Shaughnessy accepted the report, but suspended the manager for three days and fined him \$100. "That was for popping off in the newspapers about the case," explains Tighe. "I shouldn't have done that."

In the minors Tighe built an excellent reputation for his attention to detail, especially in the handling of pitchers. A case in point was Dick Marlowe's no-hitter a few years ago. As the game ended Buffalo teammates swarmed the pitcher and began pounding him on the back.

"Wait a minute," said Marlowe. "Jack had a lot to do with it. He found what I was doing wrong. He noticed my foot wasn't coming down in the same place as I delivered the ball. So Jack watched the foot while I pitched. I was so wrapped up in his coaching from the dugout that I didn't know I had a no-hitter until the ninth."

One Buffalo newspaperman, having ob-

served Tighe as a triple-A manager for two seasons, said, "We've had some fine managers around here . . . Paul Richards, Bucky Harris, Gabby Hartnett and Ray Schalk, but none of them, in my book, measures up to Tighe in handling pitchers."

Detroit considered Tighe a better-than-fair catching prospect when Billy Doyle signed him in 1935, but two years at Charleston, then two more at Beaumont in the Texas League (where he batted .220 one season) convinced the brass that Tighe would never hit. Then it was that Zeller converted Tighe into player-manager at Muskegon.

Illness put him out of uniform in the middle of the 1942 season. When he recovered he was made bullpen catcher at Briggs Stadium. He worked in a defense plant in 1943, joining the Cleveland organization in 1944 for four years, winning pennants at Batavia in 1945-46.

"Cleveland treated me very well," Tighe now says, "but Wish Egan (well known Detroit scout who died a few years ago) asked me to come back into the organization. I managed Flint in the Central League in 1948 (and won a pennant) and the next year they sent me a young fellow named Frank House," the \$75,000 bonus catcher now with the Tigers.

"The old guys on the club called him Moneybags," Tighe recalled, "but House was a fine boy. He soon won them over."

House is one of 13 Detroit players who played for Tighe in the minors, which helps to explain why he was selected for the big job. Nevertheless, the new owners were expected to pluck a so-called "name," someone with a solid managerial reputation in the majors.

It was common knowledge that Harris would not be retained as far back as July

when Spike Briggs, then the president and now the general manager, publicly criticized Harris and also the coaches, Joe Gordon, Billy Hitchcock and Tighe. Gordon quit on the spot. Hitchcock and Tighe suffered in silence. The novice owners, after buying the club from the Briggs estate, had no idea who should manage the club. They left that to Briggs and John McHale, now the director of player personnel.

"It was Tighe all the way," McHale told me. "Lots of fellows know baseball, but Tighe also knows how to handle men."

Tighe himself knew nothing of these discussions until he was called to Detroit last October 12. Five days later he got the assignment at about \$25,000 a year. Tighe himself figures to benefit handsomely from the new spirit in the firm, a contrast to the "stand pat" policy of the Briggs family. The late Walter O. Briggs fondled the team like a toy. He was wealthy enough to do so; he enjoyed being the owner of a big league team. He paid fancy wages, maybe too high to attain the best results, and was always reluctant to trade good players.

**T**HE TIGERS of the '30's always were dangerous, often a contender. In 1934, Mickey Cochrane led a brilliant team to Detroit's first pennant since 1909 and these stars—Charley Gehringer, Hank Greenberg, Tom Bridges, Schoolboy Rowe, to name a few—repeated in 1935. Owner Briggs was content to let most of his veterans die on the baseball vine rather than trade for younger men. And even when he made a profit, which was often, he plowed the cash back into stadium improvements, bonus payments, the farm system and such.

The paternal approach died with Briggs. His heirs—Spike and four daughters—had no inclination to operate the club along this pattern. The daughters, in fact, preferred cash rather than a "piece" of anything so hazardous as a baseball club. Thus, the Tigers, who need 1,000,000 cash customers to break even any year, were sold with Spike Briggs staying on to run the show. His top aides are McHale, who may eventually move into the top job, and Herold (Muddy) Ruel, the assistant to the president.

They are answerable "only" to the 11-man syndicate and the board of directors, headed by John E. Fetzer, owner of several Michigan radio stations who supposedly has \$1,000,000 of his own money in the club, and President Fred A. Knorr, radio, television and insurance executive whose idea it was to make an offer for the Tigers.

While they are waiting for Tighe to deliver on the field the front office isn't wasting any time. The TV-radio fee was boosted from \$375,000 to \$450,000, the price of box seats was raised to three dollars, the night game schedule increased to 21 (Detroit was the last American League city to install lights), and the management is pushing package ticket deals in

## DEVOTED SCRANTON, PA., ELK AND CIVIC LEADER DIES



**J**OSEPH F. CONRAD, Lackawanna County Commissioner and for many years a leader in Elk activities of Scranton, Pa., passed away March 7th at the age of 72. A lifelong resident of Scranton, Mr.

Conrad was in his second year as Commissioner, an office to which he was elected following his resignation as Scranton Postmaster after 21 years of service.

At 30, Mr. Conrad had been the youngest Scranton Elk to hold the office of Exalted Ruler, and in 1918, three years later, he assumed house managership of the Scranton Lodge home. Later he served as District Deputy for Northeast Pennsylvania.

As Postmaster, Mr. Conrad compiled an outstanding record of service. When he assumed office annual postal receipts were slightly more than \$859,000; when he retired, they had increased to over \$2,500,000. He had held various positions in the National Assn. of Postmasters and was elected its President in 1946.

Scores of men and women prominent in political, judicial and professional life joined his wife and sister in paying final tribute to Mr. Conrad at the funeral Mass celebrated at St. Mary's Assumption Church.

dozens of towns within range of Detroit.

The first-year goal of the new regime is two-fold: (1) Second place and (2) 1,500,000 cash customers. If the Tigers achieve the first the second is certain.

## \$28,006 Reward

(Continued from page 5)

but Leonard Babcock and Dan Martello split a similar bonus for such a simple suggestion that every one in the U. S. Maritime Commission kicked himself for not having thought of it sooner. Until the spring of 1956, four-man crews were assigned to make periodic checks on the surplus grain stored in Liberty ships anchored in the Hudson River. Only one man really was needed for the job. The other three tagged along simply to lift heavy, 38-foot hatches covering the storage holds. Babcock and Martello saved you and me \$150,000 a year by cutting small holes in the hatches to enable an inspector to get in and out of the holds without all the heavy lifting.

A grateful republic should issue a special stamp, or something, to commemorate John A. Overholt's rare devotion to duty beyond the call of self-interest. This defies credulity, but Overholt recommended the abolishment of his \$12,000-a-year job in the Performance Rating Section. He got a \$275 bonus for the adopted suggestion and, we're happy to report, a transfer to the Civil Service Commission's planning staff.

If you've ever been irritated by a cocksure "expert" who professes to know all the answers, you'll get a kick out of an incident that popped up two years ago in the Cleveland plant of Thompson Products, Inc., manufacturers of aircraft parts. The company's big brass and technical specialists were going crazy trying to reduce the fraying of belts on high-speed machines that polished blades for jet engines. Replacing as many as 52 belts a day on one machine was costing Thompson \$43,000 and experts were getting no place fast until Mrs. Emma Gabor, a machine operator, applied her curly head to the problem.

As every husband knows, nail polish serves other purposes besides beautifying the claws of our fine feathered friends. For one thing, it stops runs in nylon stockings. Mrs. Gabor wondered whether it would do the trick on those perishable machine belts that had to be changed every time she turned around. She dabbed a little lacquer on the edge of a belt and, by George, it worked. Mrs. Gabor received \$6,592, the largest bonus ever paid to a woman up to that time, for her down-to-earth solution of a tough nut that had stumped the masterminds in the research department. That figure was topped last year when Mrs. Veronica Hartnett was given \$5,575 and 28 shares of stock in Swift & Co., a total haul worth \$7,200, for an improved method of selecting and processing beef livers.

The suggestion box originated 500 years ago in the Venetian Republic, but it was



## Are your chances against cancer any better today?

The answer's yes . . . IF! Formerly, we could cure one out of every 4 cancer patients. Today, it's one out of 3. So why the big IF? Because the odds against cancer depend on you. Only you can give us the money we need to keep research going full speed. Remember, time is *everything* with cancer. Send a check *now* to "Cancer", care of your local Post Office.

**American Cancer Society**

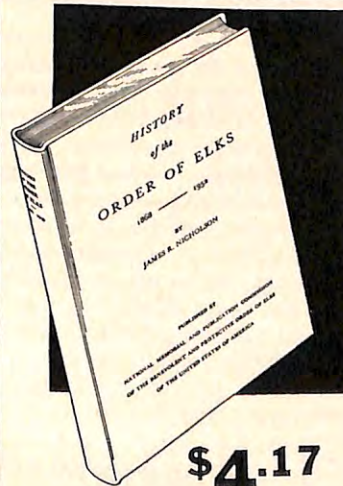

**\$4.17**

(Incl. postage & Ins.) If ordered within N.Y. City limits please add 12 cents for City sales tax.

## It's Worth Knowing More About the Elks

You'll find it more interesting and enjoyable to be an Elk when you know MORE about the Order of Elks. In the book "History of the Order of Elks" you'll find hundreds of fascinating facts—some little known to some Elks—about the Order, its many outstanding accomplishments over the years, how and why it began and what it is doing today. It's the kind of book you'll want

to re-read and keep as an important reference work. Many illustrations throughout its 482 pages and it's beautifully bound too. Send for it TODAY—for your home or your Lodge library.

### THE ELKS MAGAZINE

386 Fourth Avenue, New York 16, N. Y.

Enclosed is my remittance for the book "History of the Order of Elks".

Name (Please print).....

Street.....

City.....

## HUNDREDS OF IDEAS

### for BRONZE PLAQUES

FREE illustrated brochure shows hundreds of original ideas for reasonably priced solid bronze plaques—nameplates, awards, testimonials, honorrolls, memorials, markers.

Write For FREE BROCHURE A For trophy, medal, cup ideas ask for Brochure B.

INTERNATIONAL BRONZE TABLET CO., INC.

Dept. 40—150 West 22 St., New York 11

## 30% MORE SEATING CAPACITY

American Seating's new folding chair has independent-fold seat, saving nine inches over normal back-to-back spacing.



Upholstered spring-arch seat. Body-contour styling. Wide choice of colors and upholstery.

Write Dept. 180-F.

**AMERICAN SEATING**

Grand Rapids 2, Michigan

Branch Offices and Distributors in Principal Cities

## CHECK ASTHMA AGONY

With the first few puffs of Dr. R. Schiffmann's ASTHMADOR Cigarettes you get relief from bronchial asthma symptoms. Ask Your Druggist

**ASTHMADOR CIGARETTES**

# "FREEDOM'S FACTS"—The True Aims of Red China



In the February 1954 issue, Robert Aura Smith contributed an article which refuted the various reasons given at that time for admitting Red China into the United Nations under its present Communist government. Since then the Peiping regime, abetted by the Soviets, has been unceasing in its efforts to obtain U. N. recognition, and this month's excerpt of "Freedom's Facts" for that reason is particularly timely. "Freedom's Facts" is a bulletin published monthly by the All-American Conference to Combat Communism, of which the BPOE is a member.

If we open our morning newspaper one day and read that Red China has been voted a seat in the U. N., we can credit the event to a subtle propaganda campaign launched recently by the undeviating Reds in Peiping.

Red Chinese Premier Chou En-lai hit the theme of the program in a speech in Moscow on January 17 when he said: "We are resolutely in favor of peaceful coexistence of countries with different social systems . . . We firmly favor settling all

international differences by peaceful negotiations."

This surface show of peacefulness is especially dramatic in respect to Formosa.

In January 1955 Red Chinese were attacking the U. S. and its "Mutual Defense Treaty with the traitor Chiang Kai-shek," and a "Liberation" army was being prepared for the forcible capture of Formosa.

Within the past few months, however, the Red Chinese Premier has called Chiang "an old friend" who could have a high post in Red China if a settlement of the Formosa question could be reached.

Along the same vein, Radio Peiping on February 19 reported that a group of former Nationalist Chinese officials had been formed into a "Working Committee for the Peaceful Liberation of Taiwan (Formosa)." Their purpose: to renegotiate with the Nationalist Chinese for control of the island.

Behind this surface show of peacefulness, however, Red Chinese strategists are plotting to boost Red China into a seat in the U. N.

The recent East European and Asian tours of Chou En-lai are a part of a drive to build up Red China's prestige. "Komsomolskaya Pravda" pointed out in a January 9 editorial that, "The number of countries maintaining friendly ties with People's China is growing. Thirty-three

states with a population of over one billion have already recognized the Chinese People's Republic."

Recognition, world prestige, and professions of peacefulness are keystones in the Red Chinese drive to obtain a seat in the U. N. Red propagandists have been stressing the "growing international prestige" of Red China for the past six months. Chou's travels abroad increase that prestige still further and encourage more nations to establish diplomatic relations with Red China.

Why do anti-Communists oppose a U. N. seat for Red China? Aside from the question of principle involved—the fact that Red China has not purged itself of its aggression in Korea and is therefore not qualified for membership under the charter—there is the practical reality that the admission of Red China to the U. N. would open the door to the further spread of Communism in Asia on the one hand and, on the other, would place Red China on the U. N. Security Council and in numerous U. N. agencies where they would be in ideal positions to promote Red China's plans for Asian conquest.

These are the real aims of the Red Chinese peace talk today. Those fighting to strengthen the free world will expose Red Chinese aims and tactics and continue to frustrate her efforts to gain a seat in the U. N.

no accident of history that it was not widely adopted until the American tradition of freedom of opportunity was firmly established. The Doges of Venice, the most enlightened rulers of that age, cut slits in the walls of their palaces to enable citizens to register complaints against oppressive laws and discriminatory decisions handed down by the courts. The democratic concept of the public's right to protest injustice was abused, however, by people who wrote anonymous letters accusing enemies of trumped-up crimes. The whole thing degenerated into such a poison-pen racket that it was abandoned, but even if it had worked it would have been repressed eventually by the European caste system founded on birth and wealth.

The first suggestion box, as we know it today, was introduced by the National Cash Register Company in 1894, but the principle behind it had been flourishing in this country for a century. The self-made man, a phenomenon peculiar to America, always has been prominent in our business, cultural and political affairs because our heritage is opposed to artificial barriers that stifle individual initiative. One thread runs through practically every success story. At some point in his career a bright, young fellow attracted attention with a provocative idea that marked him as a comer and was his springboard to the head of the parade.

Most of the top executives in major

corporations today worked their way up through the ranks by proposing better manufacturing or merchandising methods than competitors were using. If they were rebuffed by stick-in-the-mud bosses, they were able to find people who had sufficient imagination to give them financial backing. In the free enterprise system, good ideas are scouted as intensively as a .350 hitter in a bush league. It's highly improbable either will be lost in the shuffle.

The National Cash Register Company's policy of encouraging suggestions from employees was copied in 1898 by Eastman Kodak. Eight years later General Electric and Consolidated Edison fell in line, and it's significant those four companies still are the leaders in their respective fields. Other budding corporations, notably General Motors and Firestone, latched onto the suggestion box, but the factory worker was pushed into the background in the 1920s by the research scientist, the new pin-up boy of industry, who was strong on theory but weak on practical experience.

The emphasis on highly specialized technicians turned the old suggestion box into a target for cartoon gags. It was depicted as a prop for office cut-ups who wrote screamingly funny notes telling the boss to drop dead or advising him that morale could be raised by adding dancing girls to the payroll. Few workers bothered to submit ideas. Management was not interested in them and those that were

adopted brought piddling bonuses of ten or twenty dollars.

All that was changed abruptly by World War II, when manpower and material shortages put a high premium on improvisation. Business forced to look for short cuts to problems never encountered before found many of the solutions in the skills and know-how of veteran employees on the production line. The neglected suggestion box suddenly became a priceless asset and progressive executives recognized it by offering more attractive incentives for ideas. The old token bonus that amounted to only a day's pay was boosted to three figures, then was multiplied several times again until workers were given the opportunity to earn the equivalent of a full year's salary. That did it. That stimulated an avalanche of ideas.

One indication of the mounting trend to suggestion boxes is the growth of the national association which promotes such programs. In 1942 the association was launched with twelve members in the Chicago area. Today it has 1,200 members and the list is expanding at the rate of 10 per cent annually.

The suggestion box now is something more than a gimmick handled by a secretary in her spare time. Nearly half the organizations in the national association maintain full-time departments that work on suggestion programs exclusively. The Illinois Central Railroad has 25 men who

dream up publicity campaigns within the company for wider participation by employees, evaluate ideas submitted and test them in the field under working conditions. In many companies, the suggestion department is regarded as important as the research division for the development of new products and better manufacturing methods.

Substantial bonuses are a great help, of course, but they are not the secret of a successful suggestion program. "Top management must give it full support all the way down the line," says Gordon E. Washburn, suggestion administrator of Abbott Laboratories in Chicago. "Employees are convinced their efforts are appreciated when they see the big brass take an active part in the program. The chairman of our board, James F. Styles, Jr., personally gives awards every two weeks and he makes the presentations in the winners' departments instead of putting the bonuses in their pay envelope with a perfunctory note of thanks. Mr. Styles says it's the most enjoyable function he performs, and his attitude is communicated to the workers.

"Every idea submitted must be given careful consideration, no matter how crazy or impractical it appears to be. If a man takes the trouble to write it down, it isn't trivial to him. When we reject a suggestion, we don't do it by a form letter. Someone in a position of authority personally tells the man why it was not adopted. Sure, it consumes a lot of time, but it pays off in the long run. In discussing an idea, we often find that a man who doesn't express himself well in writing often gives a clearer explanation of his suggestion in a face-to-face conversation. Many ideas that looked unpromising on paper have been saved in that fashion."

General Electric recently celebrated the golden anniversary of its suggestion program by installing in its Schenectady, N. Y. plant a gadget called "the golden ear" which eliminates struggling with written words, a difficulty that inhibits a self-conscious worker whose formal education has been sketchy. He simply steps on a treadle that activates a tape recorder and talks into the ear.

The small businessman who cannot afford an elaborate set-up doesn't need it to reap the benefits of a suggestion system. In fact, the simplest programs pay the highest dividends. Whenever the suggestion box is a dud, it is found that employees are so confused by forms cluttered up with legal gobbledegook that they don't bother to read further. Firms employing as few as fifteen people have obtained excellent results by encouraging suggestions through personal contact. One man who runs a welding shop hit upon the ingenious scheme of treating his eleven workers to coffee and cake one afternoon a week. While the boys sat around shooting the breeze he discussed their work and in the course of one month drew ideas from eight of them, a degree of participation never approached in large corporations.

The big trick in operating a suggestion

system is overcoming the average worker's diffidence and getting him to make his first recommendation. Once the ice is broken, he may turn out to be another Walter Millen, a die setter at Westinghouse Electric's plant in East Pittsburgh, Pa. Millen worked at Westinghouse for fourteen years before he sent in his first suggestion in 1954. An award of \$134.50 prompted Millen to submit 109 ideas in the next year, and he cashed in on 75 for a total haul of \$2,000. Another heavy hitter in the suggestion league is Patrick Fogarty, a tool-crib attendant at Cleveland Graphite. At the last count Fogarty had clicked on 26 out of 57 ideas. The all-time endurance champ is John F. Carlsen, of Irwin, Pa., who has had 312 ideas accepted in 43 years. Carlsen never has made a big killing—his bonuses add up to about \$4,000—but he's still in there thinking and hoping to hit the jackpot as Ray A. Hammerstrom did.

Hammerstrom, a mill worker, collected \$15,000 two years ago from the Jones & Laughlin Steel Corporation, and he deserved every penny of it. He designed a switching mechanism that saved a \$19,000,000 investment in a new bar mill. This may come as a great surprise to Felix Christiansen, a production mechanic at the American Can Company, but he established a new literary high a year ago when he was awarded \$10,000 for a 21-word sentence: "Use a pre-bead process on the Slaysman splitter, whereby each individual strip will come out an efficient, easily-used product." That breaks down to \$476 a word, a rate never achieved even by George Bernard Shaw, the wealthiest author of modern times.

**I**N A FAST-CHANGING WORLD where new inventions are obsolescent while they still are on blueprints, businessmen who have kept pace with our expanding economy have learned to mine the gold in suggestion boxes. Good ideas, like gold, are where you find them—sometimes in the most unexpected places. Until a few months ago the office routine in the Chicago headquarters of the National Association of Suggestion Systems was disrupted every few days by part-time clerks who were brought in to bill members for dues on the date of joining the association.

"This is a silly set-up," a girl fresh out of high school remarked to Betty Cronenworth, the office manager. "Why don't you put your members on a calendar year basis? Then you can bill them at the same time and save a lot of money."

Miss Cronenworth clapped a hand to her pretty brow and retired in confusion to her desk. "I felt like an awful dope," she confesses. "There I was, sending out bulletins to our members urging them to keep their eyes open for more efficient methods and a girl with no business experience at all showed me I was using a system older than the hills."

The moral of the story is there's always need for a fresh slant at those trees in the forest.

## People 60 to 80

**WITHIN THE NEXT FEW DAYS  
WE WILL MAIL TO YOU . . .**

. . . complete information about how you can apply for a \$1000 life insurance policy to help take care of final expenses without burdening your family.

All you need to do is give us your permission. You can handle the entire transaction by mail with **OLD AMERICAN of KANSAS CITY**. No obligation of any kind. No one will call on you.

Write today for free information. Simply mail postcard or letter (giving age) to Old American Ins. Co., 1 W. 9th, Dept. L555M, Kansas City, Mo.

## How To Hold FALSE TEETH More Firmly in Place

Do your false teeth annoy and embarrass by slipping, dropping or wobbling when you eat, laugh or talk? Just sprinkle a little **FASTEETH** on your plates. This alkaline (non-acid) powder holds false teeth more firmly and more comfortably. No gummy, gooeey, pasty taste or feeling. Does not sour. Checks "plate odor" (denture breath). Get **FASTEETH** today, at any drug counter.

## FREE FOR ASTHMA

If you suffer asthma attacks, choke and wheeze, and sleep impossible because of the struggle to breathe . . . try **FRONTIER ASTHMA MEDICINE** now! Get immediate, blessed relief from the dreaded symptoms of bronchial asthma. Over 1,000,000 bottles sold. **FREE TRIAL** bottle by return mail. You pay nothing. Send name and address now to: **FRONTIER ASTHMA CO.** 670-A Frontier Bldg., 462 Niagara Street, Buffalo 1, N. Y.

## WHEN FALSE TEETH CAUSE SORE GUMS

You get undreamed of relief in seconds! Medically-formulated **NUM-ZIT Adult Strength** has already brought blessed relief to thousands. Recommended by dentists everywhere. Pleasant-tasting . . . eases discomfort while you break in new false teeth. Works wonders, too, for relief of toothache, neuralgic pains. Keep it handy for quick first aid. **At all drug counters.**



## NUM-ZIT Adult Strength

Another fine Purepac product

## RUPTURE-EASER



Pat. No. 2606551

Right or left  
Side \$4.95

Double... \$5.95

No Fitting Required

A strong, form-fitting washable support for reducible inguinal hernia. Back lacing adjustable. Snaps up in front. Adjustable leg strap. Soft, flat groin pad. No steel or leather bands. Unexcelled for comfort. Also used as after operation support. For men, women, children. Mail orders give measure around the lowest part of the abdomen and state right, left side or double. We Prepay Postage except C.O.D.'s.

**PIPER BRACE CO.**  
811 Wyandotte Dept. EK-57 Kansas City 5, Mo.



**Easily Made Birdhouses for Contented Tenants.**

**BY HARRY WALTON**

**W**ATCHING a couple of birds set up housekeeping and raise their young can be the reward for putting up a birdhouse, as the family on *The Elks Magazine* cover this month are doing. Their cheerful songs, their busy goings and comings, make birds appealing to almost everyone. As a practical bonus, birds keep down the insect population around a house.

The more desirable birds often need encouragement against starlings and English sparrows. These multiply fast, taking over all too many natural nesting sites. Putting up an easily built birdhouse or two may induce bluebirds, wrens, robins or others to make their home with you.

Although houses should be put out as early as April, it is not too late to try for tenants this season. Wrens and robins nest several times a year. Of course the sooner you put up a house, the better the chances that it will be occupied.

**Birds Cannot Be Crowded.** They need room to find enough food, and competition is especially keen between those of the same species. One or two houses are enough for an ordinary home lot. More may only discourage home-hunting birds. If your land is big enough for several houses, space them well apart.

Identify your birds first, so as to build houses to suit them. Some are fussy. If you don't know birds, you might ask a neighbor, a scoutmaster, or the biology

teacher at the local school what kinds abound in your vicinity.

Fancy houses with miniature fences, trees, and gingerbread trimming are for people—not for the birds. Also undesirable are oversize houses, square entrance holes, and houses made of tin cans or with metal roofs, which overheat badly. Fresh paint may discourage some birds, so homes put up late may well be left unpainted.

**Make Them of Wood.** Slab wood with the bark on, old boards from fences or buildings, and even box wood is suitable. It should be about an inch thick; slab wood may vary up to 2". New wood should be rough instead of planed, especially on the inside of the house, to help fledglings climb to the entrance. If you do use smooth wood, you can nail a few thin cleats inside to give young birds a foothold.

The size of the entrance is important; to some extent it governs what species will take possession, and keeps out undesirables. It should be well above the floor, for birds like privacy when nesting. Some means of cleaning out old nests for future occupants must be provided. Perches, on the other hand, are unnecessary and even tend to encourage bird enemies.

A bird may hesitate to enter because his body in the entrance hole blocks out all light from the house. A few small holes near the roof prevent this and provide much-needed air. Without ventilation,

young birds may die from the heat. Drill such vent holes at an upward angle to keep out rain.

Let the house sides overlap the floor, rather than the floor the sides. This will keep water out of the joint. Glued joints are not necessary; parts need only be nailed together.

**A Simple Box House.** This will tempt wrens if made with a 1 1/4" hole or a slot. The latter makes it easier for birds to carry in nesting materials. Made of slab wood, the same house might attract a chickadee, nuthatch or titmouse, although these take to man-made nesting sites less readily than wrens (Figure 1).

The bottom and sides are 4" wide. Make the front twice the stock thickness wider so that it overlaps the sides. Bore or jig-saw the hole or slot in the front; then nail the bottom, one side and front to the back. Hold the roof in place to nail the upper cleat to the back. Then locate the second

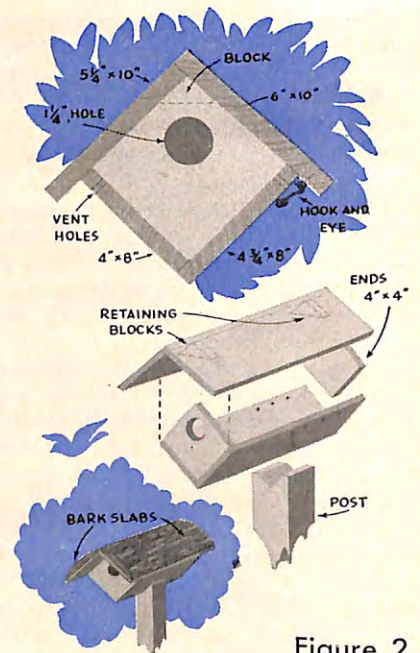

**Figure 2**

cleat, which is nailed to the underside of the roof.

To prevent high winds from lifting off the roof, drill a hole through one house wall into the inner cleat and push a nail in.

**A Ranch Style House** is shown in Figure 2. This too is for wrens, and well adapted to pole mounting. Bore the entrance hole before you cut the front to size; this will lessen the risk of splitting. Make one bottom piece 4" wide, and the other wider than this by the thickness of the first. Drill vent holes near the upper edges of both pieces.

Make one top piece wider than the other to overlap it. To rainproof this joint, either use a water-resistant glue or crease a strip of composition shingle or roofing paper and tack it along the roof ridge. Nail two small blocks into the roof peak where they will bear against the house ends, and add two hooks and eyes to lock the roof in place, one on each side.

Notch the top of the post as shown in the drawing. Remove the roof to fasten the

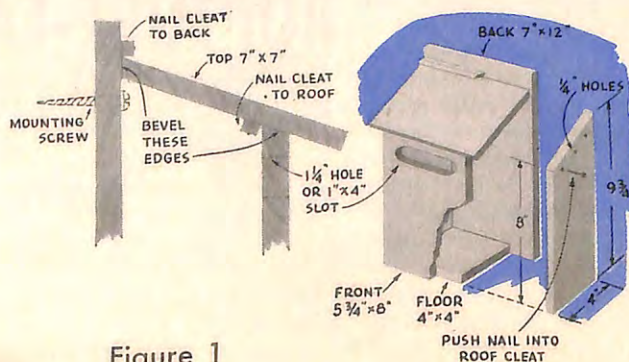

**Figure 1**



## A Quickly Made Taper Jig for Your Circular Saw



When you have to cut wedges or rip tapered members, it is easier and safer to use a jig than to hold the work by hand.

Select two pieces of absolutely straight stock about  $\frac{3}{4}$ " thick and 1" to 2" wide (plywood is a good choice). Cut them to equal length—about 15" for short work, 24" for long cuts.

Nail a  $\frac{3}{8}$ " thick block to the edge of one piece at one end. Place both pieces together and mark them 12" from the other end. Then join them with another block so that they touch at this end, using one nail in each.

Woodworking tapers are commonly given as fractions of an inch per foot. Measure the required fraction across the



12" marks and nail a second block across the open end of the jig to hold the two pieces this distance apart. Set the rip fence on the saw to rip the work to the required width.

If pieces are to be tapered on both sides, rip one side of all of them first. Then pry off the rear block and reset the jig to cut the other tapered side. Be careful not to cut into the nails in the stop block.—Harry Walton.

**\$7.95** **DRAINS** cellars, cisterns, wash tubs; **IRRIGATES - CIRCULATES - SPRAYS**

Type P Pump has 1,001 uses. Up to 3,000 GPH; 450 GPH 80' high; or 1,800 GPH from 25' well. Use 1/8 to 3/4 HP motor. Coupling included free. 1" inlet; 3/4" outlet. Stainless shaft. Won't rust or clog. . . . . \$7.95

**Heavy Duty Ball-Bearing Pump.** Up to 7,500 GPH. 1 1/2" inlet; 1" outlet. \$12.95 Postpaid if cash with order. Send for yours today. Money Back Guarantee.

**LABAWCO PUMPS, Belle Mead 58, N. J.**

**BUY DIRECT FROM - FACTORY - SAVE MIDDLEMAN PROFITS**

**MASTER MECHANIC PORTABLE LIGHT PLANTS**

(Item 24) **Push Button Start—700 watts 115 v. 60 cye. AC.** Powered by a rugged 2.2 hp. easy starting Briggs gas engine. No wiring necessary, just plug in and operate. Plenty of current for any radio, television, oil burner, freezer, pump, lights, etc. which require up to 700 watts. Ideal for camp, cottage, trailer or boat! Includes voltmeter and built-in winding to charge 6 v. auto batteries. Wt. 75 lbs. Easily fits in car trunk. Be prepared if storm knocks out power lines. Fully guaranteed. Regularly \$275 **\$143.50**

**Special.** . . . . . \$199.50

1200 Watt Plant (Item 45) same as Item 24 but with larger generator & engine—50% greater output

**FAUCET WATER HEATER**

Instant hot water for just pennies—You just slip MASTER MECHANIC's new Faucet Water Heater over any faucet—plug it in a wall outlet and you've got steaming hot water instantly for dishes, shaving, washing baby's bottle, etc. Simple and safe—operates on ordinary 110 v. house current—costs only 2 1/2 cents per hour for hot water. Ideal for homes, shops, cabins, trailers, etc. Easily regulated from lukewarm to hot hot. Fully guaranteed. Wt. 2 lbs. (Item 408) Factory price. . . . . **\$4.95**

Send 10c for Big 1957 Catalog. Free with order. Prices f.o.b. factory. 10 day money back guarantee. Send check or M.O. Master Mechanic Mfg. Co., Dept. 46-Q, Burlington, Wis.

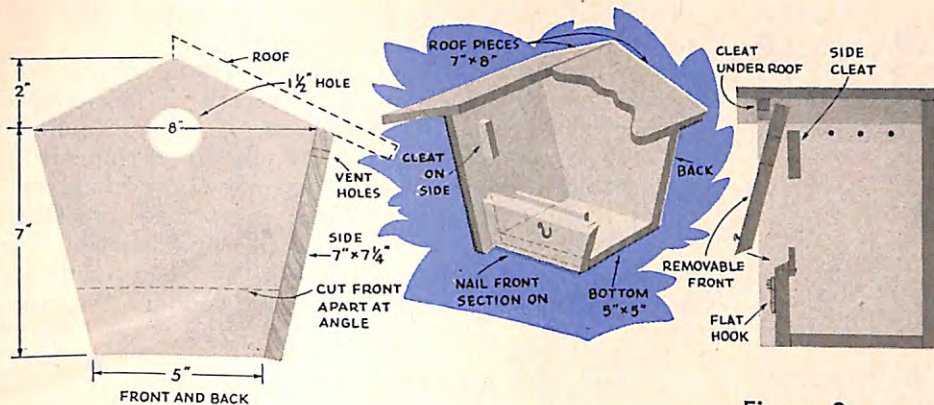

Figure 3

house in the notch with screws or nails driven through the lower sides.

**Bluebirds in the Garden** call for a house with a 5" by 5" floor, about 8" deep. Change the depth to 6" and cut the entrance hole a couple of inches lower for violet-green and tree swallows.

You can build the house shown in Figure 1 to these dimensions, or make the more picturesque one in Figure 3. Bevel two edges of the bottom and one of each side and roof piece with a plane or rasp as required to make good joints. Shape the front, cut out the entrance, and saw this piece apart at an angle.

Nail a cleat behind the high corner of the resulting bevel on the lower piece. Nail this piece between the sides. Fit the larger front piece above it and nail two cleats under the roof and one to each side to retain it. Attach a flat brass hook or a turn button to secure the removable piece at the bottom. This leaves it removable for inspection or cleaning.

**Robins Won't Nest** inside four walls. An open shelf, mounted under the shelter of house eaves, is more to their liking (Figure 4). Such a nesting site is also tempting to phoebes, or may attract barn swallows, catbirds or brown thrashers.

The back and roof are optional, but desirable if the shelf is to be mounted in a shelterless location. Cleats around the edges help hold the nest in. Drill a few holes in the floor to let water drain out.

**Woodpeckers Are Rustics.** They usually make their own nesting holes, but may be tempted by a natural-looking birdhouse. The one in Figure 5 is made of a piece of hollow log, roofed with slab wood. A cavity 4" in diameter will suit the small downy woodpecker. For other varieties and the house will have to be 6" or 7" in diameter, with a 2" or 2 1/2" entrance hole.

**Finishes For Birdhouses.** Slab wood requires no finish at all. If houses are painted, it should be in dull browns, grays or greens. Oil stains, which soak in without coating in effect. Houses that must be mounted in hot, sunny spots may be painted white to reflect some heat.

Partial sunlight is preferable, but do not pick shady spots. Face birdhouse entrances away from prevailing winds. If you mount a house in a tree, do not hide it in the foliage. Fasten it lower down on the trunk,

where it may be seen readily. Trees are easily climbed by cats and squirrels, so it is well to protect the nest by wrapping a wide collar of smooth sheet metal around the trunk, well above the height such an animal might reach by jumping.

Nests are safest from bird enemies on the wall of a building. For some of the wilder birds, which will not tolerate living so close to humans, houses on posts are a good compromise.

They need not be unreasonably high, and should never be beyond easy reach from a ladder, for old nests must be cleaned out before a new couple will move in. Locations within reach of a man standing on the ground are usually satisfactory. Bluebirds will even nest in boxes atop fence posts.

**Don't Furnish the Nest.** Birds prefer to carry in their own materials. If you put anything in the house, most birds will assume it is already occupied, and go elsewhere. For woodpeckers, however, it is safe to put in a handful of wood chips or shavings.

The houses shown in Figures 2 and 3 are readily opened for looking into the nest. Thrilling as this is, it should be done only rarely, and never while the owners of the nest are about.

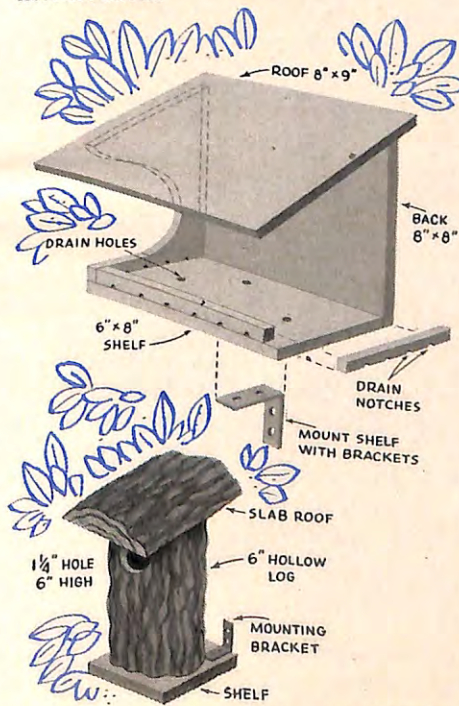

Figures 4 & 5

# Editorial

## ELK MEMBERSHIP



It is to be assumed, of course, that all Elks read in The Elks Magazine the monthly messages of the Grand Exalted Ruler.

We suggest that no one fail to read Grand Exalted Ruler Bohn's message in this issue, particularly his reference to the fact that if the Order kept on its membership list all who are initiated we would be gaining in membership at the rate of 75,000 per year instead of between 25,000 and 30,000.

There are many reasons for this loss of membership.

Grand Exalted Ruler James during his administration conducted a survey through his District Deputies, with the cooperation of The Elks Magazine and the Public Relations Department of the Order, to determine the cause of so many initiated into the Order failing to maintain their membership.

The survey was very enlightening in many respects. The outstanding revelation was the fact that the largest percentage of those who dropped or were dropped from the rolls were those who had moved away from the jurisdiction of the lodge into which they had been initiated.

He who can perfect a system of contact in respect to such Brothers designed to bring them back into the Order will find it possible to reduce materially the defection and increase accordingly the annual membership gains now enjoyed.

## TITOISM



So much has been said and written (to a considerable extent by men in public office) against the granting of aid to Yugoslavia that there comes to one as a surprise evidence of a different sentiment existing at the grass roots.

It develops that a member of the United States Congress, upon sending a questionnaire to 17,000 of his constituents treating of various subjects, had replies from 4,800 and the replies showed more than a two to one preference for continued aid to Yugoslavia.

Naturally, the principal objection to aid is that Tito is a Communist and that his country is Communist.

It would appear probable that the majority of those who replied to the Congressman's questionnaire were cognizant of those facts but still favored aid.

Perhaps they drew a distinction between a communism like that of the Union of Soviet Socialist Republics and the National Socialism of Yugoslavia.

May we not assume that they feel we have much to fear from the activities of the former—its determinations to force the whole world to accept its ideology, attempting to accomplish its purpose by stealth, by murder, by war and in violation of all the laws of God and, indeed, with the denial of the existence of God.

Perhaps those who favored aid to Tito make a proper distinction between such a communistic program and that of a nation or a leader who is willing to keep com-

munist at home and let the rest of the world follow in peace its own ideologies.

May it not be that they are also drawing a line between those who have no God, accept no God-given standards of life and the people of a country in which all religions are recognized and enjoy equal rights?

There is also the possibility that some of the Congressman's replying constituents may have had practical minds and felt that Tito, taken care of, could continue to keep his country a strong obstacle to the attempt of Kremlin Communists to subdue and conquer the free world.

## ELKS HOSPITALITY



Probably there are members of no national organization in the country more generally hospitable than the members of the nearly 1,800 lodges of the Order of Elks.

Our members have such a good record in that respect that when failures occur they stand out like the proverbial sore thumb.

Recently there came to our attention the case of a Past Exalted Ruler who moved to a new location in the jurisdiction of another lodge.

The complaint was made that when he visited the lodge where his new home was located no one paid any attention to him and when he was taken ill and the local lodge was told of his illness no one came to call.

Usually these neglects result from the idea that everyone has that someone else has taken care of the situation—that George should do it.

Might it not be a good idea for each of us under such conditions to think of each one of these situations as our personal responsibility and contribute to making our Order's reputation for hospitality not only good but perfect.

We have long thought it a good idea for the officers of a lodge and the members of the House Committee to so divide the reception responsibility as to provide that during all the open hours of the Club House someone is there having the responsibility of seeing that visiting Elks are received in the spirit of true fraternity.

## REMEMBRANCES APPRECIATED

A resident in the Elks National Home advises that since he has been in the Home he has obligated himself to scribble a line or two to every sick Brother of whom he has heard, personal acquaintance or distance not regarded.

He states that he writes these sick people with no expectation or wish for a reply; that he just wants them to know that he is thinking of them.

Already he has some 500 return reply letters, which shows that people do appreciate remembrances of this character.

Recently we heard of an important public official in a nearby city who was in the hospital with a not severe ailment but one that his physician felt could best be handled if he was not allowed to have visitors or telephone calls.

The patient, who places a high value on his friendships, allowed it to become known that while he could not receive visitors he would very much appreciate post card messages of which, of course, he received a bountiful supply.

We all like remembrances.

## Passenger-Carrying FREIGHTERS Are The Secret of Low Cost Travel

Yes, for no more than you'd spend at a resort you can take a never-to-be-forgotten cruise to Rio and Buenos Aires. Or through the Canal to either New York or California. Or to the West Indies or along the St. Lawrence River to French Canada. In fact, trips to almost everywhere are within your means.

And what accommodations you get: large rooms with beds (not bunks), probably a private bath, lots of good food and plenty of relaxation as you speed from port to port.

Depending upon how fast you want to go, a round the world cruise can be yours for as little as \$250-\$300 a month. And there are shorter trips. Fast, uncrowded voyages to England, France, or South America; two or three week vacations up and down the Pacific Coast or to New Orleans. Name the port and the chances are you can find it listed in "Travel Routes Around the World." This is the book that names the lines, tells where they go, how much they charge, briefly describes accommodations. Hundreds of thousands of travelers all over the world swear by it. Travel editors and travel writers say "To learn how to travel for as little as you'd spend at a resort get 'Travel Routes Around the World.'"

It's yours for just \$1, and the big 131-page 1957 edition includes practically every passenger carrying service starting from or going to New York, Canada, New Orleans, the Pacific Coast, Mexico, South America, England, France, Africa, the Indies, Australia, the South Seas, Japan, Hawaii, etc. There's a whole section called How to See the World at Low Cost plus pages & pages of photos and maps.

A big \$1 worth, especially as it can open the way to more travel than you ever thought possible. For your copy, simply fill out coupon.

## Will Your Next Vacation Really Be Something to Remember?

The surest way to guarantee a new, different, and exciting vacation is to learn the hundreds of things you can do and the places you can visit on the money you want to spend.

Norman Ford, founder of the world known Globe Trotters Club, tells you that in his book *Where to Vacation on a Shoestring*. This is the man who has spent a lifetime searching for the ways to get more for your money in vacations and travel. In his big book, you learn

- about low-cost summer paradises, farm vacations, vacation on far-off islands, on boats drifting down lazy streams while you fish.
- about vacations at world-famous beaches, under palm and eucalyptus trees, in government-subsidized vacation resorts, in Indian country, along rugged coastlines, on ships and by rail.
- about dude ranches you can afford; what to see, do, and how to save at national parks and in the cities most Americans want to visit.
- about low-cost sailing ship cruises, houseboat vacations in the North Woods, fantastically low-cost mountain vacations, the unknown vacation wonderlands almost at your front door.

Of course, Norman Ford knows where to get real vacation bargains in all America, from Maine to California, and in Canada, Mexico, etc. At no time does he ask you to spend a lot of money to enjoy yourself, no matter how really different and exciting is the vacation you choose through his experienced advice. Always, he tells you the many things you can do within your budget and how to get more for your money (if you travel by car, he shows how most auto parties can save \$6 or \$7 a day).

You can't help but learn something that is just meant for you. Yet, *Where to Vacation on a Shoestring* costs only \$1. To make sure your next vacation will be something to talk about, get the facts now. Use the coupon to order.

## ROUND THE WORLD ON A SHOESTRING

If you know the seldom-advertised ways of reaching foreign countries, you don't need fantastic sums of money in order to travel. You could spend \$550-\$1000 on a one-way luxury steamer to Buenos Aires—but do you know you can travel all the way to Argentina through colorful Mexico, the Andes, Peru, etc., via bus, rail and boat for just \$108 in fares?

You can spend \$5000 on a luxury cruise around the world. But do you know you can travel around the world via deluxe freighter for only a fourth the cost and that there are a dozen other round the world routings for under \$1000?

There are two ways to travel—like a tourist, who spends a lot, or like a traveler, who knows all the ways to reach his destination economically, comfortably, and while seeing the most.

Norman Ford's big new guide *How to Travel Without Being Rich* gives you the traveler's picture of the world, showing you the lower cost, comfortable ways to practically any part of the world. Page after page reveals the ship, rail, bus, airplane and other routings that save you money and open the world to you.

What do you want to do? Explore the West Indies? This is the guide that tells you how to see them like an old time resident who knows all the tricks of how to make one dollar do the work of two. Visit Mexico? This is the guide that tells you the low cost ways of reaching the sights (how 56¢ takes you via 8-passenger automobile as far as those not-in-the-know pay \$5.60 to reach). Roam around South America? Europe? Any other part of the world? This is the guide that tells you where and how to go at prices you can really afford.

If you've ever wanted to travel, prove now, once and for all, that travel is within your reach. Send now for *How to Travel Without Being Rich*. It's a big book, with over 75,000 words, filled with facts, prices, and routings, and it's yours for only \$1.50. Even one little hint can save you this sum many times over.

**Special offer: all three books above—Travel Routes Around the World, Where to Vacation on a Shoestring, and How to Travel Without Being Rich—for \$3.**

## Harian's Newest Books

Order Now for Prompt Delivery

### AMERICA BY CAR

This big book is your insurance of seeing all the four-star sights in whatever corner of the U.S. or Canada you drive to (and it even covers Mexico and Cuba as well).

Day by day, *America by Car* tells you where to go from Alaska to Mexico. Whether you're visiting New England or California, Florida or the National Parks, the Great Lakes, the Mississippi, California, the East, the South or the Southwest, the Indian country, etc., it tells you road by road the scenic way to go and it always directs you to the important sights along the way and in the cities.

In Niagara, or Los Angeles, Washington or New Orleans, the Black Hills or Montreal, *America by Car* takes the guesswork out of travel. Of course it names hundreds upon hundreds of recommended places to eat and stay.

America is so big, you can easily overlook or forget important sights or make many a wrong turn. So get *America by Car*, the book that makes sure you'll see everything of consequence and always travel right.

*America by Car* is fully 170,000 words in length (for which most publishers would charge \$5-\$8). But it costs only \$2.50, while it helps you see any part of America as you've probably never before explored this part of the world.



### THE BEST IN THE WEST

Whether you're headed for Yellowstone or Hollywood, the Indian pueblos or the Rockies, the Black Hills or the Spanish missions, seeing them with Thomas B. Lesure's 170,000 word guide is like going with a veteran traveler who's been there a dozen times before.

From San Diego to Montana, from El Paso to Seattle, there's not a place in all the West that Thomas B. Lesure won't help you explore better and with more knowledge, and he also covers the nearby strips of Canada and Mexico, places like Vancouver, Jasper, Banff, Guaymas, etc.

Of course, there's much more besides:

Are you driving? Thomas B. Lesure details the best roads to take, the scenic turn-offs, the outstanding motels and restaurants to pull up to.

Are you traveling in other ways? Here's the data you want about seeing the West without a car of your own.

Do you want a stay-put vacation? There's so much to do in the West—all the usual activities plus such things as prospecting for gold, dude ranching, mountain climbing, boating, hunting, etc., and Thomas B. Lesure makes sure you fill all your time with day after day of fun.

Going with children? You need his full rundown of things in the West that will capture their interest.

What about tipping? Is it different out West? Here are the facts you need every day on whom, when, and how much to tip. And there's still much more to this 170,000 word book (a book as long as three novels); how to get FREE souvenirs, where to find excellent buys in Indian blankets, how to visit the Indian villages, even such information as where to find the best places to live or retire in all the West.

Make your Western holiday the vacation that really gave you everything you ever wanted in a vacation. Get *The Best in the West*. Despite its enormous amount of information which you'll use every day you're in the West, it costs only \$2.50.



**Special offer: both books above—America by Car and The Best in the West—\$5 value for \$4.**

Mail to HARIAN PUBLICATIONS, 247 Spring St.  
GREENLAWN (LONG ISLAND), New York

I have enclosed \$..... (cash, check, or money order). Send me the books checked below. YOU WILL REFUND MY MONEY IF I AM NOT SATISFIED.

- America by Car*, \$2.50.
- Best in the West*, \$2.50.
- Special offer No. 1: both books above for \$4.**
- Travel Routes Around the World—(the traveler's directory of passenger-carrying freighters)*, \$1.
- Where to Vacation on a Shoestring*, \$1.
- How to Travel Without Being Rich*, \$1.50.
- Special offer No. 2: Travel Routes Around the World, Where to Vacation on a Shoestring, and How to Travel Without Being Rich—all three for \$3.**
- Special offer No. 3: All five books listed above for \$6.50.**

PRINT NAME.....  
ADDRESS.....  
CITY & STATE.....



On the threshold of a perfect Gin and Tonic...

*There's no Gin like* **GORDON'S**

