

the
Elks

magazine
NOVEMBER 1977

the
ABC's
of
Diabetes

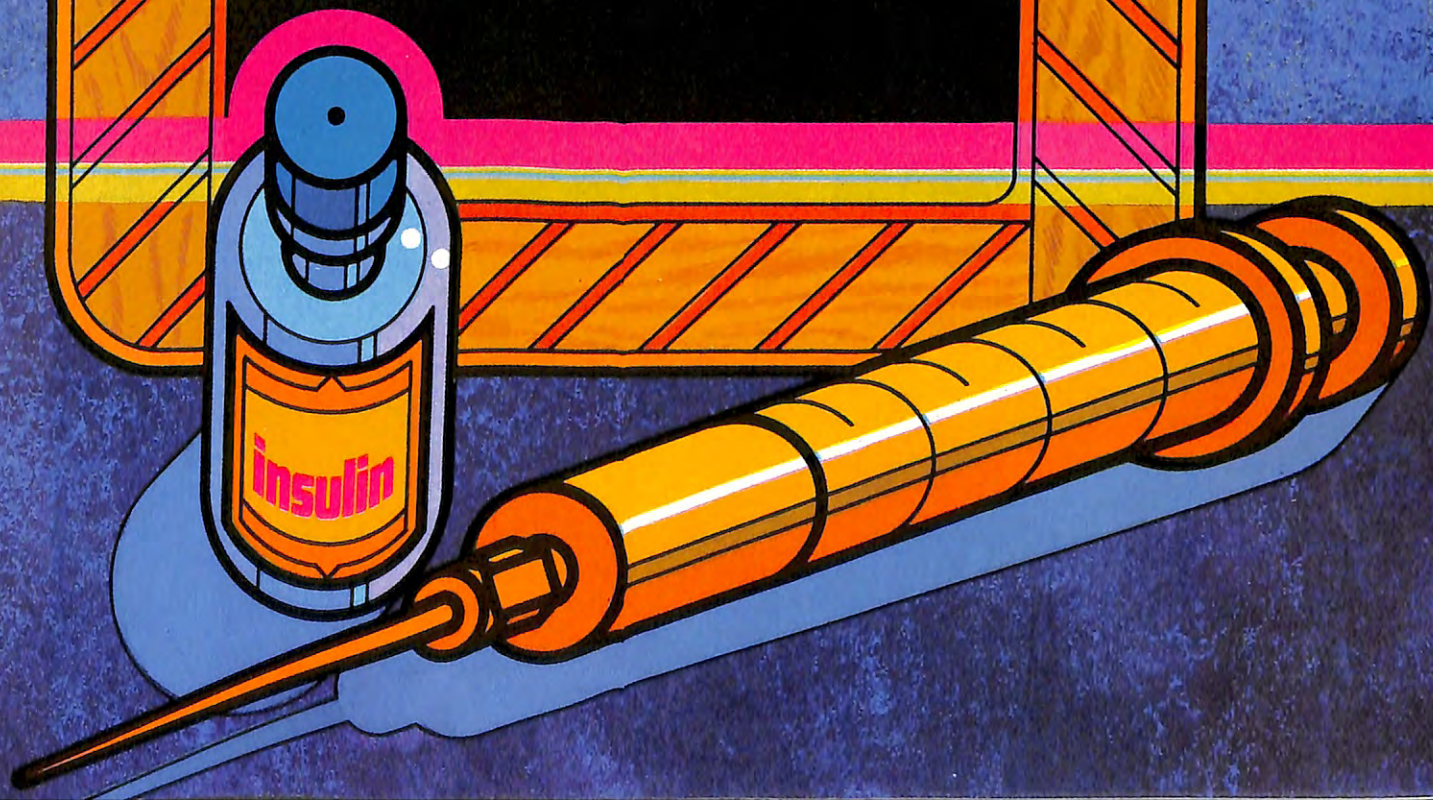

The difference between good and great.



Taste the difference Seagram's 7 Crown makes. Add one part sweet vermouth and a dash of bitters to three parts Seagram's 7. Stir with ice and strain into cocktail glass. Garnish with a maraschino cherry. Or pour over ice in a rocks glass. Either way, you've got a great Manhattan.

Seagram's 7 Crown
Where quality drinks begin.

Pocket CB

New integrated circuit technology and a major electronic breakthrough brings you the world's smallest citizens band transceiver.



The PocketCom measures approximately 1/4" x 1 1/2" x 5 1/2" and easily fits into your shirt pocket. The unit can be used as a personal communications link for business or pleasure.

Scientists have produced a personal communications system so small that it can easily fit in your pocket. It's called the PocketCom and it replaces larger units that cost considerably more.

MANY PERSONAL USES

An executive can now talk with anybody in his office, his factory or job site. The housewife can find her children at a busy shopping center. The motorist can signal for help in an emergency. The salesman, the construction foreman, the traveler, the sportsman, the hobbyist—everybody can use the PocketCom.

LONG RANGE COMMUNICATIONS

The PocketCom's range is limited only by its 100 milliwatt power and the number of metal objects between units or from a few blocks in the city to several miles on a lake. Its receiver is so sensitive, that signals several miles away can be picked up from stronger citizens band base or mobile stations.

VERY SIMPLE OPERATION

To use the PocketCom simply turn it on, extend the antenna, press a button to transmit, and release it to listen. And no FCC license is required to operate it. The PocketCom has two Channels—channel 14 and an optional second channel. To use the second channel, plug in one of the 22 other citizens band crystals and slide the channel selector to the second position. Crystals for the second channel cost \$7.95 and can only be ordered after receipt of your unit.



The PocketCom components are equivalent to 112 transistors whereas most comparable units contain only twelve.

A MAJOR BREAKTHROUGH

The PocketCom's small size results from a breakthrough in the solid state device that made the pocket calculator a reality. Scientists took 112 transistors, integrated them on a micro silicon wafer and produced the world's first transceiver linear integrated circuit. This major breakthrough not only reduced the size of radio components but improved their dependability and performance.

BEEP-TONE PAGING SYSTEM

You can page another PocketCom user, within close range, by simply pressing the PocketCom's call button which produces a beep tone on the other unit if it has been left in the standby mode. In the standby mode the unit is silent and can be kept on for weeks without draining the batteries.

SUPERIOR FEATURES

Just check the advanced PocketCom features now possible through this new circuit breakthrough: 1) Incoming signals are amplified several million times compared to only 100,000 times on comparable conventional systems. 2) Even with a 60 decibel difference in signal strength, the unit's automatic gain control will bring up each incoming signal to a maximum uniform level. 3) A high squelch sensitivity (0.7 microvolts) permits noiseless operation without squelching weak signals.



EXTRA LONG BATTERY LIFE

The PocketCom has a light-emitting diode low-battery indicator that tells you when your 'N' cell batteries require replacement. The integrated circuit requires such low power that the two batteries, with average use, will last weeks without running down.



The PocketCom can be used as a pager, an intercom, a telephone or even a security device.

MULTIPLEX INTERCOM

Many businesses can use the PocketCom as a multiplex intercom. Each employee carries a unit tuned to a different channel. A citizens band base station with 23 channels is used to page each PocketCom. The results: an inexpensive and flexible multiplex intercom system for large construction sites, factories, offices, or farms.

NATIONAL SERVICE

The PocketCom is manufactured exclusively for JS&A and is the unit currently used on the hit TV show, Charlie's Angels. JS&A is America's largest supplier of space-age products—further assurance that your modest investment is well protected. The PocketCom should give you years of trouble-free service, however, should service ever be required, simply slip your 5 ounce PocketCom into its handy mailer and send it to our prompt national service-by-mail center.

GIVE IT A REAL WORKOUT

Remember the first time you saw a pocket calculator? It probably seemed unbelievable. The PocketCom may also seem unbelievable so we give you the opportunity to personally examine one without obligation. Order only two units on a trial basis. Then really test them. Test the range, the sensitivity, the convenience. Test them under your everyday conditions and compare the PocketCom with larger units.

After you are absolutely convinced that the PocketCom is indeed that advanced product breakthrough, order your additional units, crystals or accessories on a priority basis as one of our established customers. If, however, the PocketCom does not suit your particular requirements perfectly, then return your units within ten days after receipt for a prompt and courteous refund. You cannot lose. Here is your opportunity to test an advanced space-age product at absolutely no risk.

A COMPLETE PACKAGE

Each PocketCom comes complete with mercury batteries, high performance Channel 14 crystals for one channel, complete instructions, and a 90 day parts and labor warranty. To order by mail, simply mail your check for \$19.95 per unit (or \$39.95 for two) plus \$2.50 per order for postage, insurance and handling to the address shown below. (Illinois residents add 5% sales tax). But don't delay.

Personal communications is the future of communications. Join the revolution. Order your PocketComs at no obligation today.

NEW LOW PRICE!

Credit Card Buyers Call Toll-Free

\$19.95
per unit

*Sold originally for \$40 per unit.

JS&A NATIONAL SALES GROUP

Dept. EK One JS&A Plaza
Northbrook, Ill. 60062 (312) 564-9000

CALL TOLL-FREE... 800 323-6400
In Illinois call... (312) 498-6900

©JS&A Group, Inc., 1977



Within 2 or 3 years of retirement?
DISCOVER THE BEST THAT LIFE OFFERS IN DEL WEBB'S SUN CITY

A Fabulous Arizona Resort Vacation for one or two people: Just \$150*

Get ready for a fun-filled vacation in America's most famous resort-retirement community! Golf, tennis, swimming and special parties are just a few of the things you'll be invited to enjoy. Plus you'll stay in a beautiful air conditioned apartment with a completely equipped kitchen, color TV, attached carport and private patio.

***INTRODUCTORY RATE:**

\$150 For 1 week: Oct. 16, 1977 - May 31, 1978
 For 2 weeks: June 1, 1978 - Oct. 15, 1978
 Prices subject to change without notice.
 17400 N. Del Webb Blvd., Sun City, AZ 85351

MAIL THIS COUPON TODAY!

Del E. Webb Development Co. Dept. EM-117
 P.O. Box 1725, Sun City, Arizona 85351

Send complete details on Sun City Vacation Special plus a beautiful full-color Sun City brochure to:

Name _____

Address _____

City _____ State _____ Zip _____

*Offer limited to availabilities and to vacationing parties with one member 50 years of age or older and no member under 18.

Del Webb's Sun City is NOT a lot sales development

the **Elks** magazine

VOL. 56, NO. 6 / NOVEMBER, 1977

NATIONAL PUBLICATION OF THE BENEVOLENT AND PROTECTIVE ORDER OF ELKS OF THE UNITED STATES OF AMERICA. PUBLISHED UNDER THE DIRECTION OF THE GRAND LODGE BY THE NATIONAL MEMORIAL AND PUBLICATION COMMISSION.

THE ELKS NATIONAL MEMORIAL AND PUBLICATION COMMISSION

WADE H. KEPNER/Chairman
R. LEONARD BUSH/Vice-Chairman
RAYMOND C. DOBSON/Secretary
EDWARD W. McCABE/Treasurer
ROBERT E. BONEY/Asst. Secretary and Asst. Treasurer

JOHN R. RYAN/Publisher/General Manager
JEFFREY BALL/Managing Editor
MARY M. CAVANAGH/Fraternal News Editor
MALCOLM B. CROFFORD/Circulation Manager
EDITORIAL OFFICES, 425 W. Diversey Parkway, Chicago, IL 60614

- 6 **The ABC's of Diabetes**
 Primarily a disease of later life, diabetes is now one of the most prevalent chronic afflictions of mankind. G. R. von Kronenberger
- 16 **Louder and Funnier: Humor in High Places**
 History abounds with leaders whose sense of humor never left them, no matter how grim the work at hand . . . Joseph Stocker
- 31 **Marathon**
 The Cincinnati Elks Marathon is the second oldest in the nation.

DEPARTMENTS

- 4 Message
- 11 Obituary: Hobert L. Blackledge
- 14 It's Your Business: Christmas, 1977
- 18 Elks National Foundation/
Joy of Giving
- 19 Grand Lodge Officers
and Committees
- 21 You and Retirement: When to Retire
- 22 Travel: Steamboat Cruises
- 26 Elks National Foundation
Scholarship Awards
- 27 News of the Lodges
- 33 Visits of Homer Huhn, Jr.
- 36 News of the State Associations
- 42 Elks National Service Commission
- 44 Elks Family Shopper/
More For Your Money.

ADVERTISING OFFICES



CHICAGO 60614 425 W. Diversey Parkway (312) 528-4500
 NEW YORK 10017 50 East 42nd (212) 682-2810

POSTMASTER: Mail notices of address corrections to:
THE ELKS MAGAZINE, Circulation Dept., 425 W. Diversey Parkway, Chicago, IL 60614
MEMBERS: Changes of address should be made through your lodge Secretary. Give him advance notice of at least 30 days. Remember that the day you write, your next copy is already in the mails. Before you move, file your new address at the post office to have mail forwarded. In writing us regarding an address change, please give: Full name, lodge number, membership number, address to which copy is being mailed, and complete new address. Attach label from recent issue if available. Please show ZIP Code numbers in both old and new address.
 THE ELKS MAGAZINE, Volume 56, No. 6, November, 1977. Published monthly at 425 W. Diversey Pkwy., Chicago, IL 60614 by the Benevolent and Protective Order of Elks of the United States of America. Second class postage paid at Chicago, IL, and at additional mailing office. Acceptance for mailing at special rate of postage provided for in Section 1103, Act of October 3, 1917, authorized May 20, 1922. Single copy price 25 cents. Subscription price in the United States and its Possessions, for Elks, \$1.25 a year, for non-Elks, \$2.50 a year; for Canadian and Foreign postage, add \$1.00 a year. Subscriptions are payable in advance. Manuscripts must be typewritten and accompanied by sufficient postage for their return via first class mail. They will be handled with care but this magazine assumes no responsibility for their safety.
 The word, Elks, is a registered trademark of The Benevolent and Protective Order of Elks of the United States of America. Copyright, 1977, by the Benevolent and Protective Order of Elks of the United States of America



Does Your Lodge Need...

- BANQUET OR UTILITY Tables?**
- FOLDING OR STACKING Chairs?**
- PLATFORMS, STAGES OR Risers?**
- CONFERENCE, OFFICE OR CLASSROOM Furniture?**

Find what you need in our new **FREE Catalog** — and buy at factory-direct prices! Fill out and mail this ad today!

NAME _____

ADDRESS _____

CITY _____

STATE _____ ZIP _____



Send To:
THE MONROE COMPANY
 90 Church Street
 Colfax, Iowa 50054

NEW! Electronic Ceiling Projector Clock

Projects the Time on your Ceiling

Electric Alarm

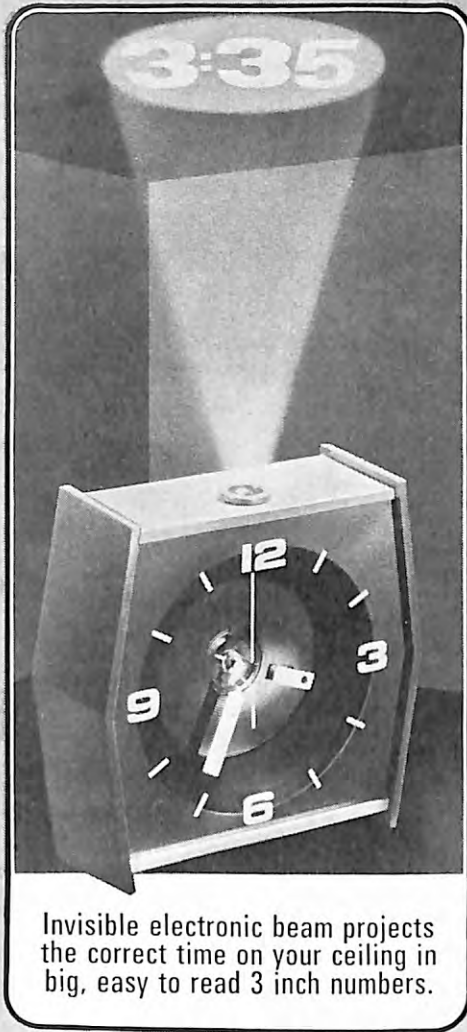

Invisible electronic beam projects the correct time on your ceiling in big, easy to read 3 inch numbers.

- INVISIBLE BEAM HAS NO GLARE TO KEEP YOU AWAKE
- CORRECT TIME IS PROJECTED CONTINUOUSLY ON CEILING—OR CAN BE SWITCHED OFF
- SOFTLY LIGHTED DIAL FACE ALSO SHOWS CORRECT TIME IN CONVENTIONAL MANNER
- PLEASANT BUT FIRM ALARM BUZZER
- MADE IN U.S.A.—FULL ONE YEAR FACTORY WARRANTY



\$19.95



See the time at a glance—from anywhere in the room—even in the dark!

At last someone has invented an alarm clock that clearly shows the time in the dark—WITH NO NIGHT-LIGHT GLARE TO KEEP YOU AWAKE! The latest word in modern timepieces, this new electronic alarm clock magically projects the correct time on your ceiling in big, easy to read, 3 inch digital numerals. Allows you to see the time in the dark from anywhere in the room, with just a glance at the ceiling. Time projector feature will run continuously, or you can switch it off if you prefer and tell the time from the conventional softly lighted dial face. Wakes you up with a firm but gentle alarm. No batteries, just plug it into any AC outlet. Full one year factory warranty. U.L. approved. Measures 3" deep X 6" wide X 6½" high.

A Great Gift Idea!



ELECTRONICS INTERNATIONAL

210 S. Desplaines St. Chicago, Ill. 60606

MONEY BACK GUARANTEE

ELECTRONICS INTERNATIONAL Dept. CHD-62
210 South Desplaines Street, Chicago, Ill. 60606

Gentlemen: Please rush on money-back guarantee _____ Electronic Ceiling Clocks at \$19.95 plus \$2 each for Pstg. handling & Insurance

- I have enclosed \$_____
- Ship C.O.D. I enclose \$2.00 deposit.

(Ill. residents please add 5% Sales Tax)

Name _____

Address _____

City _____ State _____ Zip _____

Master Charge BankAmericard American Express

Acct. No. _____ Good Thru _____

Interbank No. _____ (Find above your name) XSignature _____

YOU MAY CHARGE YOUR ORDER

**A message from the
Grand Exalted Ruler**

REMEMBRANCE IN THANKSGIVING

During November all lodges are urged to observe Veterans Remembrance Month to hold special ceremonies, fund-raising affairs and collection campaigns for items needed by hospitalized veterans.

It's all too easy to forget these men and women who weren't as lucky as most. That's why we Elks have promised that we shall never forget them as long as there are any of them here to need our help.

And they do need our help. They need our compassionate interest in them and their affairs. They need the many things that we can and do supply for their comfort and pleasure. Above all, they need to know that we care, that they are not alone, that they will never face the dreadful desolation of being forgotten.

This is such an admirable program, and I urge all of our members to support it wholeheartedly.

What better way is there for us to express our thanks during this time of Thanksgiving? We have so many things to be grateful for. Our country is at peace with other nations. We enjoy a greater tranquility at home. Our economic troubles are lightening.

So let us join in showing our gratitude to those who have served our country so well in time of peril, as we thank Almighty God for His abundant blessings, especially for the strength and wisdom to stand firmly by the principles and ideals that distinguish our nation among all others.

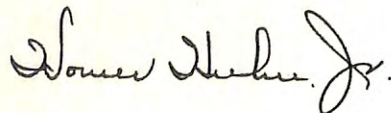

Homer Huhn, Jr.

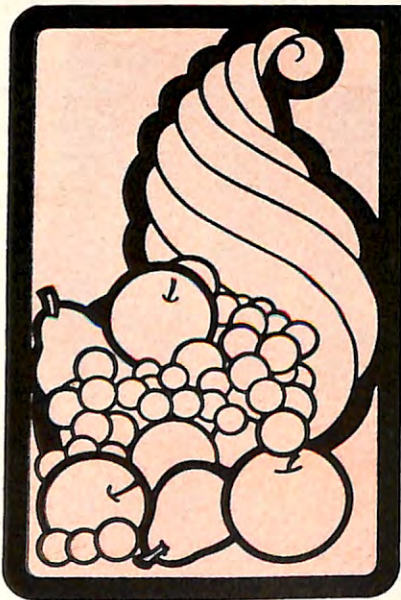

**“Individual
Responsibility
—Assures Progress”**

GIANT MEMO CALENDAR

**YOUR
SPECIAL
PHOTO
ENLARGED
400%
IN FULL COLOR**

FULL
COLOR
PHOTO

NEW FOR 1978

only **\$2⁹⁹**

FROM
THIS



■ Now your favorite photo can become a superb, lasting and beautiful wall calendar—to hang all the year long where it will bring you pleasure every day. Or, as a gift to remind a special person of your thoughtfulness and love.

A new scientific breakthrough makes it possible to **enlarge**, with absolute fidelity and clarity, any color photo and reproduce it in GIANT size. You get all the tones, all the beauty, all the vibrant live colors, so exactly that the giant photo seems actually **better than the original!**

Any photo—color or black and white—can be used, and will be returned to you in perfect condition. Even a tiny 3" x 4" snapshot becomes a giant 8" x 10" printed on a fine quality linen-look calendar that is 14" x 22" overall. And the calendar is a year-round aide, with plenty of room for notes, reminders, appointments, red-letter days, etc.

The price is super, too. Only \$2.99! An incomparable value these days. Just send your favorite photo or slide. We'll even mail calendars for you to any list of people you want to send us.

Use handy order coupon. Prompt service and satisfaction guaranteed.

©BENNETT-GRAF, Inc.
1450 N. E. 123 Street, Miami, Fla. 33161



BENNETT-GRAF, Inc. Dept. 3529
1450 N. E. 123 Street, Miami, Fla. 33161

We use Kodak paper
For a good look.

Please rush _____ Giant Photo Calendar(s) enlarged from the photo(s) enclosed. (When ordering calendars to be sent to more than one person, enclose list of names and addresses on separate sheet).

For each calendar I enclose payment of \$2.99 plus 50¢ to help defray postage and handling charges.

Total Payment enclosed \$ _____ (N Y residents, add sales tax)

SEND TO (NAME) _____
STREET _____
CITY _____
STATE _____ ZIP _____

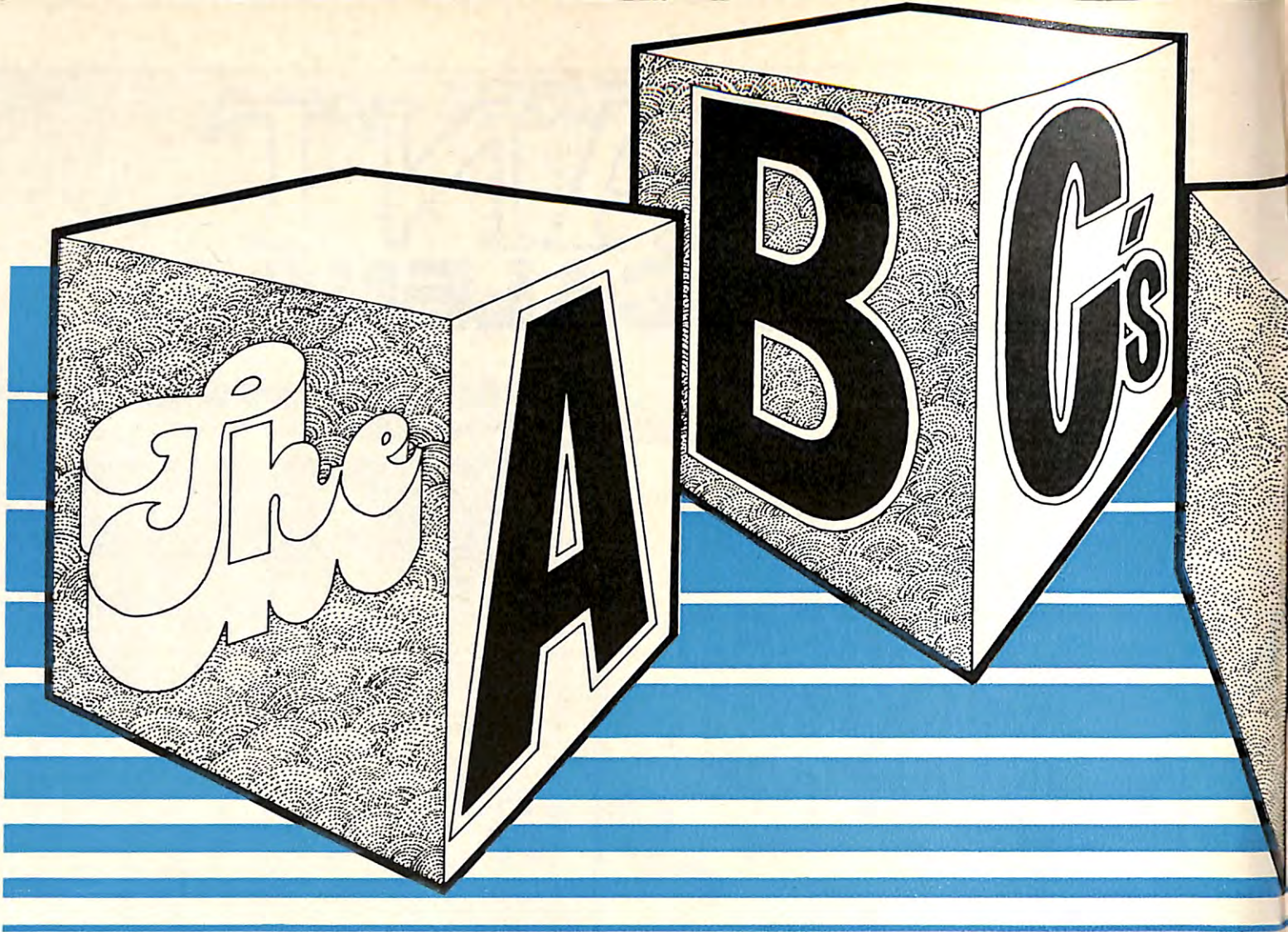

□ *Diabetes mellitus*, commonly called diabetes, is one of the most prevalent chronic afflictions of mankind, and the numbers of those afflicted with it are increasing every year. There are several reasons more people have diabetes now than forty or even twenty years ago. Diabetes is primarily a disease of later life, and more elderly people are alive today than a few decades ago. Scientific discoveries have enabled doctors to diagnose the disease and keep their patients alive. Moreover, our habits have changed. More of us are city dwellers—we have a higher standard of living, eat more rich food, and get less exercise. All these factors contribute to the startling increase of diabetes in this country. The number of diabetics in the United States has burgeoned from 1.2 million in 1950 to an estimated 5 million now, an increase of more than 300 percent while the population has grown only about 50 percent. In addition, it is estimated this same malady is lurking in a mild but potentially dangerous form in another 5 million Americans *who don't know they've got it.*

Dr. Bertrand E. Lowenstein, a diabetes researcher, points out that diabetes "remains today one of medicine's most baffling riddles. No one knows

what really causes it, how to prevent it, whether it is one disease or two or three, or how to prevent the far-reaching and devastating effects it has on the human body."

Recent findings of the National Commission on Diabetes show that last year 38,000 persons died directly from diabetes, and there is strong evidence that perhaps as many as 300,000 deaths could be attributed to diabetes and its complications. This would make diabetes the third-ranking cause of death, after heart disease and cancer.

Additional statistics on diabetes are not reassuring. According to the U.S. Public Health Service, the disease is currently a leading cause of blindness, kidney failure, disorders of the nerves and tiny blood vessels, gangrene of the limbs and various sexual malfunctions. Diabetes has also been associated with heart attack, stroke and other cardiovascular diseases. The upshot is that more than 50 years after the discovery of insulin treatment the mean life expectancy of the diabetic is still 25 percent shorter than that of the non-diabetic.

Each year the nation's economy sustains at least a 5 billion dollar cost that is attributable, both directly and in-

directly, to the effects of diabetes. Direct costs include visits to the doctor, fees for blood-sugar tests, costs of drugs, equipment, hospital and nursing home care. Indirect costs include those connected with the 11,000 productive man-years lost annually because of sickness absenteeism among currently employed diabetics and the 500,000 lifetime man-years of production lost because of premature death from diabetes.

Diabetes is not the exclusive property of certain persons or special groups; it is the true believer in equality—it visits man and woman, the poor and the rich, the young and the old, the blue collar worker and the successful executive.

Diabetes is a disease in which the body is unable to use or store the sugar it needs. In the normal human mechanism, sugar either is burned to make energy or heat or is stored in the liver, the muscles, and the skin. In the case of a diabetic, most of the sugar goes directly into the blood, and some of it goes into the kidneys and is passed off. Everyone has some sugar in their blood and in their urine, but diabetics have far too much.

The excess sugar in the blood and urine of the diabetic is caused by a

by G. R. von Kronenberger

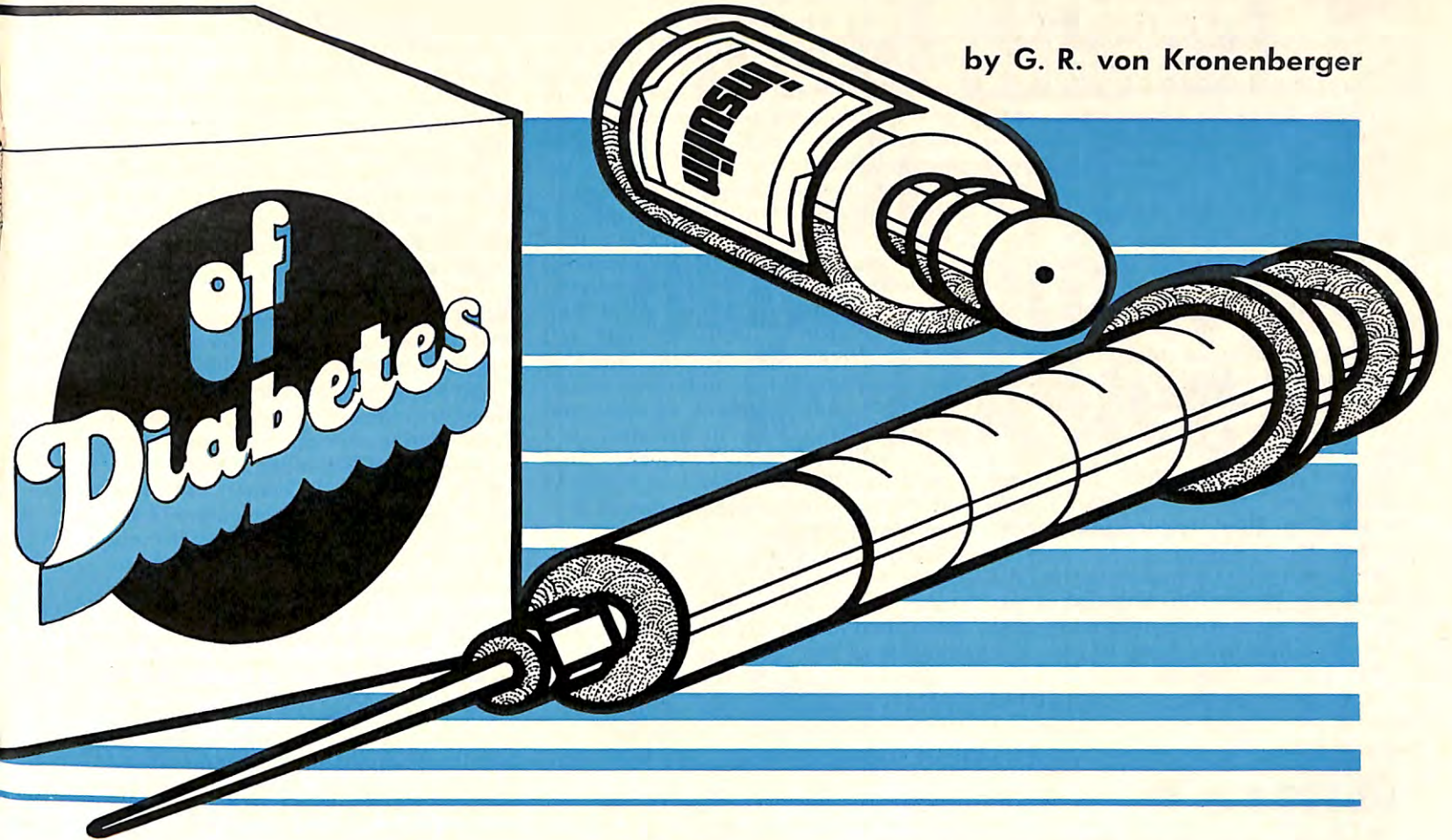

disturbance of the delicate balance among the liver, the pituitary gland, the adrenal gland, and the pancreas, the gland located just below the stomach and near the liver. The pancreas manufactures natural insulin, the substance needed to break down the sugar in the body. In a diabetic, there is an impairment of insulin activity. Either the body does not produce enough insulin, or the action of available insulin is somehow "blocked" from performing its primary task of facilitating the entry of glucose (blood sugar) into the cells of the body.

Insulin seems to affect the metabolism of fats and proteins as well as sugar, for, as diabetes progresses, abnormal carbohydrate metabolism becomes associated with derangement of the metabolism of fats and proteins.

In its severe form, diabetes develops rapidly to a state of grave metabolic derangement called keto-acidosis, which may result in coma and death unless controlled by insulin injections. In its less severe form, the disease results in accelerated degeneration of the arteries. Insulin can stop the symptoms of diabetes but not the complications. Although the abnormal glucose level can be held in check, the long-term compli-

cations of diabetes—primarily those affecting the blood vessels, kidneys, peripheral nerves, and the eyes—cannot be prevented or adequately treated.

Diabetes strikes in two forms, both of which, say doctors, can be controlled. The symptoms—sudden weight loss, constant thirst, frequent urination, extreme hunger, general weakness, drowsiness and fatigue, itching of the skin (especially in the area of the genitals), visual disturbances—such as blurring, and unusual skin disorders (boils, carbuncles, or infections)—are the same for both forms.

In juvenile-onset diabetes, the more serious of the two types, the disease occurs most frequently in childhood and adolescence. Of the estimated 5 million known diabetes cases in this country, probably only half a million are juvenile-onset-type cases. The average age for juvenile-type diabetes to strike is about 12. The patient's ability to manufacture insulin to handle his blood sugar tends to deteriorate rapidly. The disease progresses swiftly with hardening of the arteries in many parts of the body. Damage to blood vessels can cause blindness, gangrene in limbs necessitating amputation, heart attacks, kidney failure, and other serious conditions.

Although the majority of such patients can be maintained with regular insulin injections (some have been kept alive and well with insulin for periods of 20, 30, 40 years), their life spans tend to run about 30 percent shorter than that of the average person.

Maturity-onset diabetes, which accounts for at least 85 percent of all cases, usually has its clinical start between the ages of 35 and 60 and mainly in people who are overweight. The factor most strongly and consistently associated with the prevalence of maturity-onset diabetes is the degree and duration of obesity. The chance of being diabetic more than doubles for every 20 percent of excess body weight. Also the risk of contracting the disease doubles for every decade of life.

Maturity-onset diabetes is generally less severe than that seen in young patients—not progressing so rapidly or so often to serious complications. Most patients do not require insulin injections and can maintain their blood sugar at relatively normal levels by controlling their weight, adhering strictly to a low-carbohydrate diet, and by the use of oral antidiabetic drugs.

Of diabetics not requiring insulin—principally those with the maturity-on-



set form of the disease—about 1.5 million are currently taking oral hypoglycemic agents.

These are drugs, given by mouth, that enhance insulin release or action in persons with some insulin production of their own. Oral hypoglycemic drugs have been widely used in the treatment of maturity-onset diabetes since they were introduced some 20 years ago. In 1970, after publication of the findings of a diabetes research group, controversy arose over the drugs, and use of these agents temporarily declined but quickly resumed their steady expansion. The controversy revolves around interpretation of the results of a nine-year study of 1,027 patients conducted by 12 universities cooperating as the University Group Diabetes Program (UGDP). The UGDP found that more diabetic patients taking the oral agents died from fatal heart attacks than those taking either insulin or placebos. Other scientists have challenged these findings, asserting that some of the patients had cardiovascular disease to begin with and that others had diabetes in such mild form that they should not have received any drug—they feel the drugs are safe.

After reviewing the data contained in the UGDP report the American Medical

Association and the American Diabetes Association both supported the findings and issued warning statements for the use of the drugs. In 1972, the Food and Drug Administration decreed that the drugs be specially labeled. The new labels stipulate that doctors first recommend diet for the control of maturity-onset diabetes and that when this is impossible or is ineffective, insulin is to be preferred over the oral drugs.

According to Dr. Sigrid A. Hagg of the Thorndike Memorial Laboratory in Boston, "When diet and weight reduction are ineffective or not feasible, clinicians must choose between insulin and oral agents. The UGDP study demonstrated that insulin is the safer and more effective approach to control of blood glucose. Most authorities would withhold full approval of the oral agents; the decision to use them still rests with the individual patient and physician. Patients should be informed of the potential risks and should participate in the decision..."

At present, the experts generally do agree that any decision about which mode of therapy is best should be an individual matter between each patient and his or her physician.

Contrary to the belief of many, diabetes is not a disease of recent origin. An Egyptian papyrus, dating back to-

ward 1500 B. C., describes in precise detail an ailment with all the earmarks of diabetes. Even the words, *diabetes mellitus*, come from antiquity, the disease having been named by Aretaeus, a student of Hippocrates. In the language of Homer, *diabetes* means "to pass through" and *mellitus* is the equivalent of "sugar." Not only did the Greeks have the words for it, but the words were excellent ones since one of the primary symptoms of diabetes is sugar in appreciable amounts passing through the blood stream and out of the body in the urine.

Certain interpreters, going back to Biblical times, wondered whether Job, with his boils and other afflictions, was not really a victim of diabetes.

Between the 6th and 17th centuries, there was almost no progress in the study of this scourge. A few physicians in India and China observed a disorder which they called "honey urine" because ants flocked around urine of patients so afflicted. During the 17th century Thomas Willis, physician to Charles II, had the wisdom to taste the urine of the diabetic. His description of this historic event ushered in the modern era of the study of diabetes. The urine, Willis states, "is wonderfully sweet as if it were imbued with honey or sugar." But it wasn't until 1840, and the beginnings of scientific animal experimentation in France, that new avenues were opened to the control and analysis of the disease.

Science discovered the ductless glands in the human body. It was observed that the pancreas furnishes an important digestive juice for the intestine, and the connection between the pancreas and diabetes was recognized for the first time in the 1800s by a German scientist, Oscar Minkowski. As with other significant medical discoveries, Minkowski's contribution to the understanding of diabetes came about quite by accident. Like the husband who looks under the bureau for a missing cuff link and finds instead a long-lost tie pin, Minkowski was doing research on the pancreas and discovered a scientific link—the connection between diabetes and this small human organ. Minkowski's self-appointed task was to determine the effect of removal of the pancreas in dogs. Not more than 15 hours after he removed the organ from one of his canine patients he noticed that the animal was behaving strangely. Lying on its side, more dead than alive, the animal tried feebly to drive away the flies that swarmed in droves on and around his hindquarters. An unusual number of flies, Minkowski noted. He walked over and noted that the flies were attracted not to the animal but to the dog's urine. Testing the fluid verified the fact that it contained

There's big money in small business

Small businesses all over the country—and right in your own community—need professional help in the areas of recordkeeping, management and tax preparation. This need for services has created an ever-expanding career opportunity for professional business counselors.

General Business Services has helped nearly 1000 career-minded men and women start practices as independent business counselors. But the need is far from filled. GBS can help you take advantage of this opportunity, too.

With thorough GBS training and time-proven GBS financial control systems, you can start your own business counseling practice in a matter of weeks. An investment of \$15,000 provides complete training, inventory and supplies, and the full technical support of an experienced national office staff.

To learn more about a big career in small business, return the no-obligation coupon below.

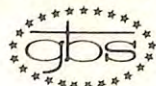
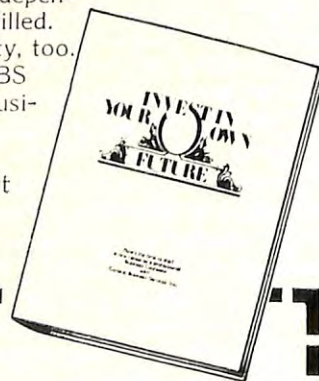

General Business Services, Inc.
Department EM-S-11
51 Monroe Street
Rockville, MD 20850

Please send me your free brochure, "Invest in Your Own Future," about a GBS career.

Name

Address

City State Zip

Phone Best time to call

a high percentage of sugar. As Minkowski stated later in a paper describing his experiment, by removing the pancreas, he created a condition in the dog that was "similar to the grave form of the disease [diabetes] in man, and [which persisted] without interruption until the death of the animal." Subsequent investigation by other scientists linked the disease to the specific areas of the pancreas, the islets of Langerhans, from which body insulin is derived.

In the pancreas of normal individuals the islets of Langerhans, more than a million pin-sized clusters of cells, are scattered throughout the organ and mete out exact doses of insulin in response to the slightest sugar rise. First described in 1869 by Dr. Paul Langerhans, a German physician, the islets comprise less than two percent of the six-inch-long pancreas, but produce all the insulin.

The pancreas itself is a large gland, averaging about 70 grams in humans, and is attached to the duodenum, a portion of the small intestine connected to the stomach. The pancreas is composed of two main elements—exocrine tissue and endocrine tissue.

Exocrine tissue makes up the bulk of the pancreas. It is organized into a large number of sac-like structures whose interiors are lined with cells that secrete various enzymes important to the digestive process. These enzymes flow through passageways in the pancreas into a large duct through which they are released into the duodenum.

Scattered throughout the exocrine tissue are small, isolated pockets of endocrine tissue—these are the islets of Langerhans. The islets may be composed of several different types of cells, but the predominant constituents are the alpha and beta cells, which generally occur in the ratio of four beta cells to each alpha cell. Both types of cells contain small organelles, known as granules, that have been identified as the source of the hormones produced by the pancreas. Granules in the beta cells produce insulin, while those in the alpha cells produces glucagon. Both hormones are secreted directly into the bloodstream.

It is this insulin which the body of the diabetic either is unable to produce or incapable of utilizing fully. The diabetic lacks the means for normal utilization of certain ingested foods, chiefly carbohydrates. Where the disease is mild, often in those instances where its presence has been detected early, control of the ailment may require only that the amount of sweets and starches eaten by the diabetic be reduced. In other words, the carbohydrate intake is regulated so that available body insulin will be sufficient for proper utilization.

Read this ad. It will make your legs feel better.

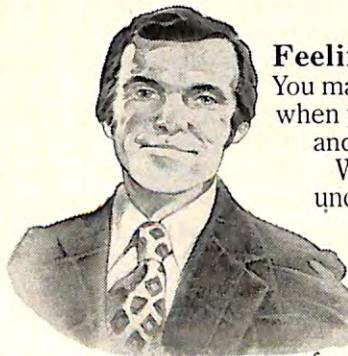

Feeling good all over starts with your legs. You may feel just great. Ready and rarin' to go. But when your legs feel like they're totin' around a ball and chain, it's hard to think about anything else. We call it "leg fatigue." You call it just plain uncomfortable.

And if each day you're becoming more and more aware of aching calves and throbbing leg muscles, chances are you haven't yet discovered Supp-hose Socks.

Supp-hose Socks are the result of years of careful scientific research.

But to really appreciate how different they are, let's begin from the ground up.

Why your legs give out before you do.

Simply stated—poor circulation. You see, when it comes to your circulatory system, what goes down must come up. That's the whole problem.

Blood traveling down to your legs may have a hard time getting back up again. This reduces the flow of fresh oxygenated blood to your legs. The result: leg fatigue.

How Supp-hose works.

Even before you slip into Supp-hose you'll know they're no ordinary socks. You'll see the exclusive vertical and horizontal ribbing which actually helps to reduce leg fatigue. Put them on, and you'll feel a perfectly proportioned fit. Snug around the lower leg. Not too tight around the calf.

Supp-hose acts like a gentle massage to ease leg tension and help promote a more even flow of blood through the legs.

Not only will your legs feel good, they'll look good, too. Supp-hose unique support system helps hold your leg muscles in place. And gives your legs a better shape.

If tired legs are slowing you down, slip into Supp-hose Socks. They'll help you remember how good your legs can feel.

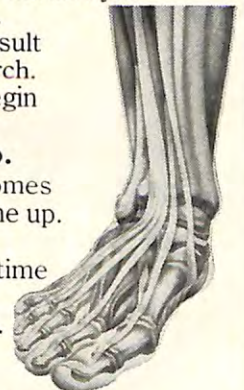

Supp-hose® Socks

It must say Supp-hose to be Supp-hose.

Another fine product of Kayser-Roth



But regulating the diet is not sufficient for many diabetics. Additional insulin extracted from the pancreas of animals is required by these persons to compensate for the lack of the hormone secretion in the body.

The idea of using animal insulin was first hinted at by Minkowski and Joseph von Mering in 1890 in a paper describing further experiments with dogs. After the pancreas was removed from a dog, the animal was fed ground, raw pancreas from a freshly killed sheep. The dog was immediately resuscitated after his meal. The apparent recovery was short-lived. However, an idea was presented—lack of human insulin could be compensated by insulin from animals. As hundreds of scientists and researchers who labored so long and so unsuccessfully on the problem could attest—it's easier said than done. The search for means of using animal insulin was crowned with success many years later in 1922 when two young Canadians, Frederick Grant Banting and his assistant Charles H. Best were able to extract the life-giving hormone. For their epochal discovery, the two Canadians and their colleagues shared in the award of the Nobel prize.

Mere words cannot describe the impact of this discovery. Practically over-

night, tens of thousands of doomed persons were granted a new lease on life. In the George F. Baker Clinic in Boston, one of many examples that might be cited, the death toll among diabetic children was reduced by more than 500 percent! During the period between 1914 and 1922, 386 out of every 1000 children admitted to the clinic died. For every 1000 young persons aged 20 almost half of them died. Yet, in the period between 1922 and 1925, when insulin was in full use at the clinic, the number of deaths among children was only 61 per thousand. The number of young adults was 89 per thousand.

The insulin extracted in 1922 and improved crystalline types of pure insulin developed thereafter act almost immediately in the human body and are completely utilized within a number of hours. For the diabetic to have the required full day's quota of insulin, two or three injections daily were required. A minor inconvenience, considering the benefits derived—yet, an inconvenience nonetheless. Even this minor shortcoming was overcome when in 1936 Dr. H. C. Hagedorn of Copenhagen, in collaboration with scientists at the University of Toronto, succeeded in prolonging the action of insulin by adding zinc and protamine to the hormone secretion. Protamine, a type of protein obtained from the sperm of

Pacific salmon and from certain other fishes, acts to retard and protract the insulin's effect. Thus, one injection of protamine zinc insulin, taken in the morning or at some other time indicated by the physician, lasted at least 24 hours and provided a steady supply of needed insulin to the diabetic's system. In recent years, other insulin types have been perfected and techniques for administering combinations have been developed.

Today three types of insulin are in common use. *Fast acting insulin* lowers blood sugar rapidly but only temporarily. It reaches peak activity in 3 to 4 hours and disappears in 6 to 8 hours. It usually is used when infections, acidosis, surgery or other emergencies increase the immediate need for insulin. *Intermediate activity insulin* reaches its peak action in 8 to 12 hours but lasts from 24 to 30 hours. It prevents a rise in blood sugar following meals during the day and tapers off at night when less is needed. *Slow acting insulin* may be used to control mild diabetes in older people. All types of insulin are available from pharmacists everywhere.

Manufacturers of insulin estimate that there are about 1.25 million persons who are dependent on daily injections of insulin that is extracted from the pancreas of beef and pork coming to slaughter. Insulin cannot be taken by mouth as it is a protein that would be destroyed in the stomach and intestines.

The discovery of means for using animal insulin has by no means meant the end of research and scientific study on diabetes. Literally thousands of papers are published annually in medical and scientific journals. In clinics and laboratories throughout the world, skilled researchers experiment and probe the mysteries which still surround diabetes.

All forms of the disorder are presently incurable and the causes of diabetes are still unknown. Improved control and ultimate eradication of diabetes can be accomplished only through research. Continued advances against this enigmatic foe will depend on further knowledge of the mechanism of the disease and its complications; of genetic factors; of how insulin is produced in the pancreas, and how it is transported and works, and how, and by what agents, it is destroyed or inactivated. Intensive studies in these areas are presently being conducted and supported by the National Institute of Arthritis, Metabolism, and Digestive Diseases (NIAMDD), the federal agency most deeply involved in diabetes research, and should contribute substantially to more effective control of diabetes and its consequences.

In a 1973 NIAMDD-supported study
(Continued on page 12)

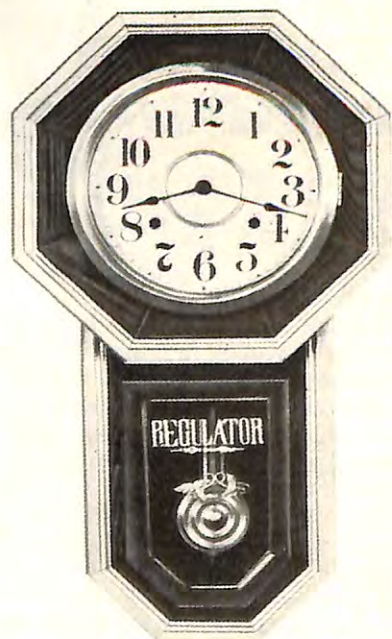

The Original Schoolhouse Clock \$98.00

- Satisfaction Guaranteed or money refunded.
- Certificate of age, authenticity, ownership.
- Fully re-conditioned 8-day keywind movement, brass pendulum, key. Counts each hour in deep melodic tones.
- Finely polished and carefully restored case, approx. 22" H, 13" W, 4½" D.

ONE OF AMERICA'S LAST GREAT ANTIQUÉ BUYS

You are invited to become one of the few Americans today lucky enough to own not a copy, not a replica, not less than an authentic circa 1900 antique schoolhouse clock—the kind that once ticked happily away in the front parlors, general stores & one-room schools of our childhood. Each is unique & in 100% running order. Yours will be numbered, registered to your family or whomever you designate and accompanied by a handsome **Certificate of Age & Ownership** (suitable for framing). You could expect to pay far more at auction or antique shop for just such a clock. **To assure ownership at this special price, please order now.**

FOR FASTER SERVICE ON CREDIT CARD ORDERS
call (914) 248-7031 9 A.M. to 5 P.M. (E.S.T.)

Visit Our Showroom, Just 50 miles from N. Y. C.



PONY EXPRESS SYSTEM
2986 Navajo St., Dept. M-111
Yorktown, N.Y. 10598

Please send me _____ clock(s) @ \$98.00 plus \$6.00 for insured delivery for each. Please register to the name(s) attached. My check is enclosed for \$_____. (N.Y. State residents add 5% sales tax.)

We Honor Master Charge, American Express & BankAmericard. Include signature & appropriate data or for faster service call 914-248-7031.

Mr./Ms.

Address Apt. #

City State Zip

Past Grand Exalted Ruler Hobert L. Blackledge

HOBERT L. BLACKLEDGE, Grand Exalted Ruler for the 1957-1958 lodge year, died September 12, 1977.

Brother Blackledge became an Elk in 1927 and served as Exalted Ruler of Kearney Lodge No. 984. In 1939, he was elected Trustee, serving four three-year terms. Under his leadership as chairman of the board, Kearney Lodge prudently saved the funds that made possible its new home dedicated in 1956, one of the finest in the Midwest.

In 1945-1946 he served as District Deputy Grand Exalted Ruler and was President of the Nebraska Elks Association in 1952-1953.

Brother Blackledge was a leader in our rituals. From 1947 through 1952 he was in charge of ritualistic work in Nebraska, and was instrumental in bringing Nebraska to its present high plane in this field. In recognition of these services, the Nebraska Elks Association has designated its annual award the "Hobe Blackledge Ritualistic Trophy."

Named to the Grand Lodge Committee on Judiciary in 1948, Brother Blackledge served seven years on this committee, two years as its chairman, with great benefit to the Grand Lodge and credit to himself. He compiled and edited the 1955 edition of the Annotated Statutes, a testimonial to his talents and devotion. In 1955, Brother Blackledge was appointed a Justice of the Grand Forum, the highest court of our Order, where he served until announcing his candidacy for Grand Exalted Ruler. He was elected Grand Exalted Ruler of the Order for the year 1957-1958.

Brother Blackledge served as a member of the Grand Lodge Advisory Committee and was a Trustee of the Elks National Foundation to which he was appointed in 1958. He was the Vice-Chairman of this committee.

In his professional life, he enjoyed the highest respect of the Bench and Bar of Nebraska for his ability and integrity.

His civic affairs were wide and varied. He served 15 years as Trustee of the Kearney Public Library. As a member of the Episcopal Church, he served several terms as Senior Warden and was for many years Chancellor to the Bishop.

PGER Blackledge is survived by his wife Helen. Services were held at St. Luke's Episcopal Church in Kearney, Nebraska, with a special Elks memorial service conducted there.



A week in sunny Arizona ...only \$115 for two.



In Green Valley, Arizona... just twenty-five miles south of Tucson... over 6,000 people like you enjoy carefree, sunny retirement all year long. Come sample this life for seven days and nights for \$115 for two. (From May 15 through December 15, rate is only \$75.)

You'll stay in a lovely vacation casita complete with linens, cooking utensils, telephone and television. You can enjoy swimming, tennis, sightseeing, lots of good company, and golf at moderate greens fees.

All we require is that you provide your own transportation and meals, and you or your companion be at least forty-five.

Green Valley is for real, and for now. We have stores, shops, churches, medical facilities, service clubs, banks, even our own fire department.

And wait 'til you see our fifteen new model homes. They're loaded with new energy-saving construction ideas, and easy-living design features.

If you are interested in an extended visit, check the rent/lease information box in our coupon.

Information and tours

When you make Fairfield Green Valley your vacation headquarters, you're in the right place for any number of short, interesting, self-guided tours. There are places like Nogales, Mexico, just forty-two miles south. And "too-tough-to-die" Tombstone, only ninety-four miles east. And, of course, Tucson, just twenty-five miles north. Our staff will be happy to provide you with all the information you'll need.

There's a wonderful week waiting at the other end of our coupon. Please send it today.

That Green Valley Grin Comes from living good again



Reservation Department

ELKN117

Fairfield Green Valley

Post Office Box 587
Green Valley, Az. 85614
Phone (602) 625-4441

Enclosed find \$ _____ for _____ days and nights beginning _____

- I would like more information.
 Please send rent/lease information also.

Name _____

Address _____

City _____ State _____

Zip _____ Phone _____

This advertisement does not constitute an offer to sell land in Nevada, New York or those states where such an offer is prohibited by law

of particular significance to juvenile diabetics, researchers at the University of Texas in Dallas have found that diabetics produce excessive amounts of glucagon, a hormone also manufactured by the pancreas, with biological actions diametrically opposed to insulin. If an agent can be found to inhibit excessive glucagon production, it is possible that insulin activity can be normalized and diabetic complications prevented or postponed.

Recently, the Salk Institute announced that it had won federal approval of a licensing program to manufacture such an agent.

The new discovery, a brain hormone called Somatostatin, was isolated three years ago during studies of how the brain regulates the pituitary gland in its secretion of several important hormones. The researchers discovered that Somatostatin inhibits the secretion of pituitary gland growth hormones which have been implicated in the development of vascular lesions and the blindness of juvenile diabetes. They also found that Somatostatin inhibits the secretion of glucagon known to be secreted in excess in diabetics and leading to high blood sugar levels. University of California researchers in San Francisco already have revealed that Somatostatin can lead to considerable reductions in the amount of insulin needed to maintain normal blood sugar conditions, and it is predicted the hormone will eventually become a regular part of the treatment of diabetes.

The day may be coming when diabetics will no longer have to inject themselves daily to maintain a workable insulin level. Instead, they will have a compact electronic sensor attached to a blood vessel in the pancreas to monitor the blood sugar level and automatically release the appropriate amount of insulin as the level changes.

The sensor is just one of many projected developments reported from the scientific community in the continuing effort to improve treatment and control of diabetes. Along with the discussion of such advances as transplants and oral insulin, diabetes researchers are even beginning to talk hopefully about discovering a cure for the disease. Welcome as these advances are, their practical application will take time, and however they may lessen or simplify the necessity of providing insulin to the diabetic, they will not necessarily prevent the development of complications until the cure is found.

In addition to federal research programs, private voluntary agencies such as the American Diabetes Association and the Juvenile Diabetes Foundation, which was formed in 1970 to deal specifically with the problems of young diabetics, are initiating and supporting

research in these areas. They are also providing information and education programs for patients and their families, for physicians and other health professionals, and for the general public.

The inspired work being done now on diabetes as well as the efforts of pioneering scientists mean absolutely nothing if persons afflicted with the ailment do not receive prompt and adequate medical attention. The existence of 5,000,000 untreated cases of diabetes is an affront to those men and women who have devoted their lives to treating the disease. The existence of this large group does much to negate the progress in conquering diabetes.

The sensible, often-repeated advice that everyone should have a medical examination at least annually cannot be reiterated too often. If for no other reason, the visit will positively eliminate the possibility of undetected diabetes. If this is done diabetes will be caught in its early stages when it can be treated most successfully. The sooner the disease is discovered, the easier is its treatment. This is of course true for all human ills and it is especially true of diabetes.

Not only can diabetes be discovered and treated successfully, but to an important degree, steps can be taken even to prevent its occurrence. The cardinal rule of prevention is to avoid overweight. This is especially valid advice for persons over 40 years of age.

The second rule of prevention is to check the factor of heredity. The consensus of medical opinion does recognize that there is this factor in diabetes. If the disease has already made its appearance somewhere in a person's family, they should be cognizant of the fact that they too might fall victim. Recognizing the danger, a person should take the extra precaution of protecting themselves and members of their family.

The third rule is the familiar one—see your doctor at least once a year for a thorough medical examination, and especially a urine analysis and blood-sugar test.

The 5,000,000 cases of untreated diabetes stand as a warning to all. The disease is a prevalent one and, if untreated, a most dangerous one. Each person owes it to himself and to his family to make certain that diabetes does not creep up undetected and take its toll of happiness and well-being.

The battle against diabetes is still far from won. Though substantial progress has been made, an enlightened public, supporting research and education efforts, is necessary to help assure further advances, thus brightening the prospects of all diabetics for a full life. ■

defy the COLD!

It's 10° outside . . . Even getting colder. So you bundle up in layers and layers of heavy clothes. First with long underwear . . . then bulky, restrictive thermalwear on top.

Oh, you were warm all right. Like in a Turkish bath. Because you began to perspire from all your activity. And perspiring in that mountain of clothes is like perspiring in a plastic bag! The perspiration is locked in. So there you are. Wet and miserable.

But now, at last, Damart has solved the problem. Because Damart invented underwear that keeps you *warm, dry and comfortable* no matter how cold it is or how long you stay out. Underwear that's soft and light so you can move easily. Underwear that *lets the perspiration evaporate through* so you always stay warm and dry next to your skin.

Damart does this with a new miracle fabric—Thermolactyl. It not only retains and reflects your natural body warmth, it's knitted to let *perspiration out!* No other underwear does this! Damart Thermolactyl is so comfortable that the Mount Everest climbing expedition wears it. So does the Glencoe mountain rescue team and the entire Chicago Bears Football Club.

Our free color catalog tells the full Damart Thermolactyl story and displays the whole Damart line for men and women. Send for your FREE copy now!



TALL
SIZES
NOW
AVAILABLE

THE PROOF IS IN THE WEARING!

Damart Thermawear, Inc.

WHEN IN THE BOSTON AREA, VISIT OUR
PORTSMOUTH, N.H. STORE. (603) 431-4700



THERE IS NO WARMER UNDERWEAR MADE!

Fill out and send to:
DAMART, INC. Dept. EK117
1811 Woodbury Ave.
Portsmouth, N.H. 03801

YES! Rush me your FREE DAMART Catalog . . . I want to enjoy the fantastic warmth of Thermolactyl Underwear, a DAMART® exclusive. (I understand there is no obligation.)

PRINT NAME _____

ADDRESS _____

CITY _____

STATE _____

ZIP _____ © 1976, Damart, Inc.

Make up to \$12⁵⁰ an hour

Start your own money making business!

Be Your Own Boss!

Hundreds of Belsaw trained men have succeeded in this fascinating and highly profitable field...

YOU Can Do It Too!

BE A LOCKSMITH

Never before have money-making opportunities been so great for qualified locksmiths. Now lucrative regular lock and key business has multiplied a thousandfold as millions seek more protection against zooming crime. Yet there's only one locksmith for every 17,000 people!

FREE BOOKLET!

Train FAST at Home - Collect CASH PROFITS Right Away. You're "in business" ready to earn up to \$12.50 an hour a few days after you begin Belsaw's shortcut training. Take advantage of today's unprecedented opportunities in locksmithing for year-round EXTRA INCOME in spare-time-or fulltime in a high-profit business of your own. Hundreds we've trained have done it. So can YOU! All tools plus professional Key Machine given you with course. These plus practice materials and equipment, plus simple, illustrated lessons, plus expert supervision, plus business-building guidance will enable you to KEEP THE MONEY COMING IN! Ideal for retirement-good jobs too. **SEND FOR EXCITING FACTS—No Obligation! ALL SPECIAL TOOLS AND EQUIPMENT INCLUDED!**

PRO KEY MACHINE YOURS TO KEEP!

RUSH COUPON! Send for your copy today!

Accredited Member National Home Study Council

10-DAY NO RISK TRIAL! BELSAW INSTITUTE 138V Field Bldg. Kansas City, MO. 64111

There is **NO OBLIGATION** and **NO SALESMAN** Will Call—ever!

FREE! BELSAW INSTITUTE
138V Field Bldg., Kansas City, Mo. 64111
Please rush **FREE** Book "Keys to your Future."

NAME _____

ADDRESS _____

CITY-STATE-ZIP _____

\$ FIND LOST TREASURE \$

Find lost coins, jewelry, buried treasure, valuable relics, and gold nuggets with new revolutionary patented detector. Nothing like it before, makes other detectors obsolete. Astounding range, rejects metallic trash. Unaffected by black sand or mineralized ground. Free catalog.

GARDINER ELECTRONICS
Dept. 28 • 4729 N. 7th Ave. • Phoenix, Az. 85013

"SILVER COIN SPECIALS"

Order Now While Supply Lasts
Silver coins are becoming very rare
Your investment will double in 5 years

10-All Different-EF-Roosevelt Dimes	\$ 4.95
10-All Different-EF-Mercury Dimes	\$ 9.95
10-All Different-EF-Washington Quarters	\$12.50
5-All Different-EF-Franklin Halves	\$14.95
5-All Different-BU-Silver Morgan Dollars	\$49.95

Add 75¢ for mailing, postage, insurance and catalog.
For catalog only, send 35¢ which lists all coins.

DEL'S INC. (SE)
P.O. Box 81407, Lincoln, Nebraska, 68501

MODERN - OBSOLETE - FOREIGN DOMESTIC - MILITARY - SPORTING

WORLD'S LARGEST SUPPLIER
GIANT CATALOG #7
\$2.00 PDD

GUN-PARTS

NUMRICH ARMS CORP.
Box ELK, West Hurley, New York 12491

ELECTRIFY YOUR BIKE!

PEDALPOWER exciting new bike drive tames tough hills. Be independent. Shop when you want. Fits all Bikes, Adult Trikes. Installs in minutes. Thousands sold. Recharges overnight. Travels 100 miles for a dime.

Send for **FREE** illustrated booklet.

GENERAL ENGINES CO.,
5601 Mantua Blvd., Sewell, N.J. 08080

IT'S YOUR BUSINESS

by John C. Behrens



A MERRY, NON-INFLATIONARY CHRISTMAS

Christmas, 1977.

Most people don't want to believe it's so close. Businessmen, on the other hand, have known for days it's just around the corner. They're hopeful they either bought enough goods or not enough depending upon what's left on their shelves in January. And therein, incidentally, is one of the most monumental problems of our economy.

One New York finance specialist and economics professor, Allyn Earl, believes that the coming season had better be a good one or Jimmy Carter's second Christmas in the White House could be gloomy.

"I think this will be a slightly better Christmas season than last year based upon what I see," Earl forecasts. "This is a critical question really because 1978 in large part is going to depend upon what happens to the biggest selling period of the year. For example, if this is a dud, Christmas retailers are going to find themselves overstocked insofar as inventories are concerned and are going to have to work off stock in the first few months of next year.

"That means they're going to reduce their ordering of new stock which, of course, gets down to the factory level and employment at this level. So if the Christmas season is a big one, I can foresee a very good first half in 1978—at least not recessionary certainly. If it's a real bummer (an unusual term for an economist but to the point) as Christmas seasons go, then we can get another small inventory recession," Earl continues.

Last Christmas was not bad, he says. The country was in the middle of an economic recovery and the expansion was still in full swing. "The point is that the coming Christmas season has got to be a little better than last year if the recovery is to keep moving. This has been a decent year but it hasn't been as strong as some economists have been looking for. The question is how long can the consumer keep the ball rolling. Usually by fall the capital expenditure comes into play and we usually find strength in that. We haven't found it yet."

The obstacles to a good Christmas, though, are real to those who watch seasonal changes. "If there is a late surge in consumer prices that usually means that people become more hesitant to buy because they begin worrying about job security. They know that inflation in the

past has led to periods of higher unemployment," he continues.

Yet, economists are cautiously optimistic generally about what they see.

In a general preview on the economy in a major eastern newspaper earlier in the fall, a variety of business and government officials pointed to what they thought were good indicators. A senior economist in the Northeast noted that two chronic unemployment areas in New York State, for example, have been below last year's figures. While the two areas may experience some increase in unemployment between now and Christmas, the economist felt the number of unemployed would still be lower than last year.

But how can the small businessman tell what's going on without hiring an economist?

"Here I would pay very careful attention to what's happening in retail sales right through the Christmas buying season. By the middle of this month or early December we should have a fairly decent idea of what's happening. Another thing to watch are some of the leading indicators especially in the area of business spending for durable goods, plants and equipment, new construction and that kind of thing. The index of leading economic indicators gets popular press coverage in virtually any daily and, of course, the business journals."

The New York analyst predicts that during the next year to year and a half the inflation problem will gradually come under control. "By coming under control I mean probably at an annual rate of below 5 percent and maybe even 4 percent by late 1978. The reason for that, in my opinion, is our energy situation. Some improvement is coming in the way of the Alaskan oil which will reduce our dependence upon foreign oil. This is a short run type of thing but it should provide help. Food prices, too, should be down in the coming months if reports are accurate."

What will 1978 be like for the small businessman?

"A decent year with some qualifications," he contends. "A good year if there's a better Christmas season, better signals in the home construction field and if we get more help from capital expenditures."

Address your questions and comments to John C. Behrens, c/o The Elks Magazine, 425 Diversey Parkway, Chicago, Illinois, 60614.

How To Launch Your Own Business For Under \$1,000 and Make \$25,000-\$50,000 a Year

Management consultant David D. Seltz is one of the nation's foremost authorities on small businesses. He has written some 12 books on the subject and more than 2,000 articles which appeared in such publications as *Nation's Business*, *Dun's Review*, *Business Management*, etc.

He has spent the last 14 months researching 18,292 small business opportunities to compile the first complete directory of *the most profitable small businesses* you can start in your spare time for under \$1,000 (many for under \$500).

He has published his findings in a new book called, *"A Treasury of Business Opportunities,"* published for anyone who's dreamt of owning a business.

In its fascinating pages, you'll learn . . .

- How Michael S. makes \$50,000 a year in a small community by providing a little-known, simple service needed by the graduating class of every high school and college. His student customers are easy sales and his work consists mainly of placing phone calls.
- How John H. runs a weekend business that uses other people's vacant land to rake in as much as \$10,000 profit per weekend. No equipment, no investment, no employees needed!
- How James P. charges \$2,000 for a simple service most businesses need, but few people are aware of. He has so much business, he doesn't even advertise!
- How Ronald P. earns \$100 per week on a \$200 investment supplying a service needed by most storefront merchants.

You'll learn about a unique new product that's selling like wildfire to religious people and gives you a 500% markup. You'll discover an easy-to-start business that nets about \$25,000 profit in the summer months alone. You'll be given the amazing inside story of a business that requires so little of anything, you could run it out of a phone booth. Yet it's quietly making better than \$50,000 a year for scores of men and women.

And this is just the beginning! You'll learn how to rake in enormous finder's fees for putting two types of common business clients in touch with each other. You'll discover why certain national manufacturers will pay you upwards of \$40,000 a year for making local contacts for them. You'll see how to start a business in which moonlighters work their tails off to earn you \$50,000 a year.

You'll learn where to haul away crates of what some businesses consider "junk" — but which other businesses need des-

perately and will pay you as much as \$60,000 a year for. You'll discover a product that costs pennies to make, sells for \$5 and is wanted by thousands in just about every community. And you'll be shown how to start an exclusive kind of club which can bring you more than \$50,000 a year from people who'll feel *privileged* to pay you a hefty membership fee just for the right to belong!

You'll see how to sell a *few sheets of paper* for as much as \$2,000 to businesses all over your home town You'll read about the "dead flower" strategy that requires only one visit per customer per month yet gives back up to \$25,000 per year in return You'll discover how to get people all over your community gladly lend you their cars and then just as gladly pay you up to \$50,000 a year to perform one simple, nonmechanical act with those cars.

You'll read the remarkable story behind one little-known business that is not only depression-proof, but actually does fantastically well when the economy grows worse. Not only are the profits potentially enormous in this business, but there is this unexpected advantage: Simply by issuing your own business card as a dealer enables you at once to buy men's suits for \$22, metal tennis rackets for \$8, electric typewriters for \$85, and dozens of other items far below wholesale.

If you or your spouse like to "putter" around the kitchen, just turn to page 68 of this book and see how you can make that puttering yield you a spare-time income of \$25,000 a year.

And if that's not enough to get you started in your own little "goldmine" business, wait till you discover . . .

© 1977 Farnsworth Publishing Co., Inc., Rockville Centre, N.Y. 11570

- The instant travel business that gives you up to 50% discounts when you wish to go on a trip.
- The simple idea that lets you run your own sweepstakes—with *someone else* putting up the prizes!
- The method for earning thousands of dollars on other people's inventions.
- 23 different ways your car or truck can help produce profits every day for you.
- The way to turn each of your handyman friends into a spare-time income of \$25,000 a year for you.
- The technique for having your products displayed and sold in the finest homes in your area—with sales as high as \$500 per home. This one strategy alone may be worth 100 times the cost of the book—and it's all yours on page 217.

**FOR FAST SERVICE
CALL TOLL FREE
800/621-8318 —Dept. K3**
(Illinois Res. 800/972-8308)
If you charge BankAmericard
or Master Charge

30-DAY NO-RISK GUARANTEE

The *"Treasury"* is so crammed full of ingenious, *proven* money-making ideas, that we feel certain you will find in it the key to make your dreams of financial independence come true. Send today for your 30-day trial copy of *"A Treasury of Business Opportunities,"* by David D. Seltz. If, for any reason, you should be dissatisfied with the book, just return it and every penny of your money will be refunded immediately.

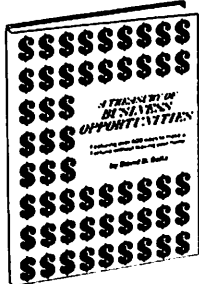

This oversize 8½" x 11" format book uncovers dozens of little "goldmine" businesses. It gives you everything you need to get started in your own profitable business, in your spare time, with minimum capital.

FARNSWORTH PUBLISHING COMPANY, INC. Dept. K3
78 Randall Ave., Rockville Centre, N.Y. 11570

Please rush my copy of *"A Treasury of Business Opportunities,"* by David D. Seltz, featuring the 154 most profitable businesses I can start in my spare time for under \$1,000. My money back in full if I'm not 100% delighted.

Enclosed is my check or money order for \$16.25 (\$15.00 + \$1.25 postage & handling).

Please charge my BankAmericard #.....
 Master Charge #.....
 InterBank #.....
 Exp. Date.....
 Signature.....
 Name.....
 Address.....
 City.....
 State..... Zip.....

N.Y.S. residents please add applicable sales tax.

Louder and Funnier:

humor in high places

by Joseph Stocker

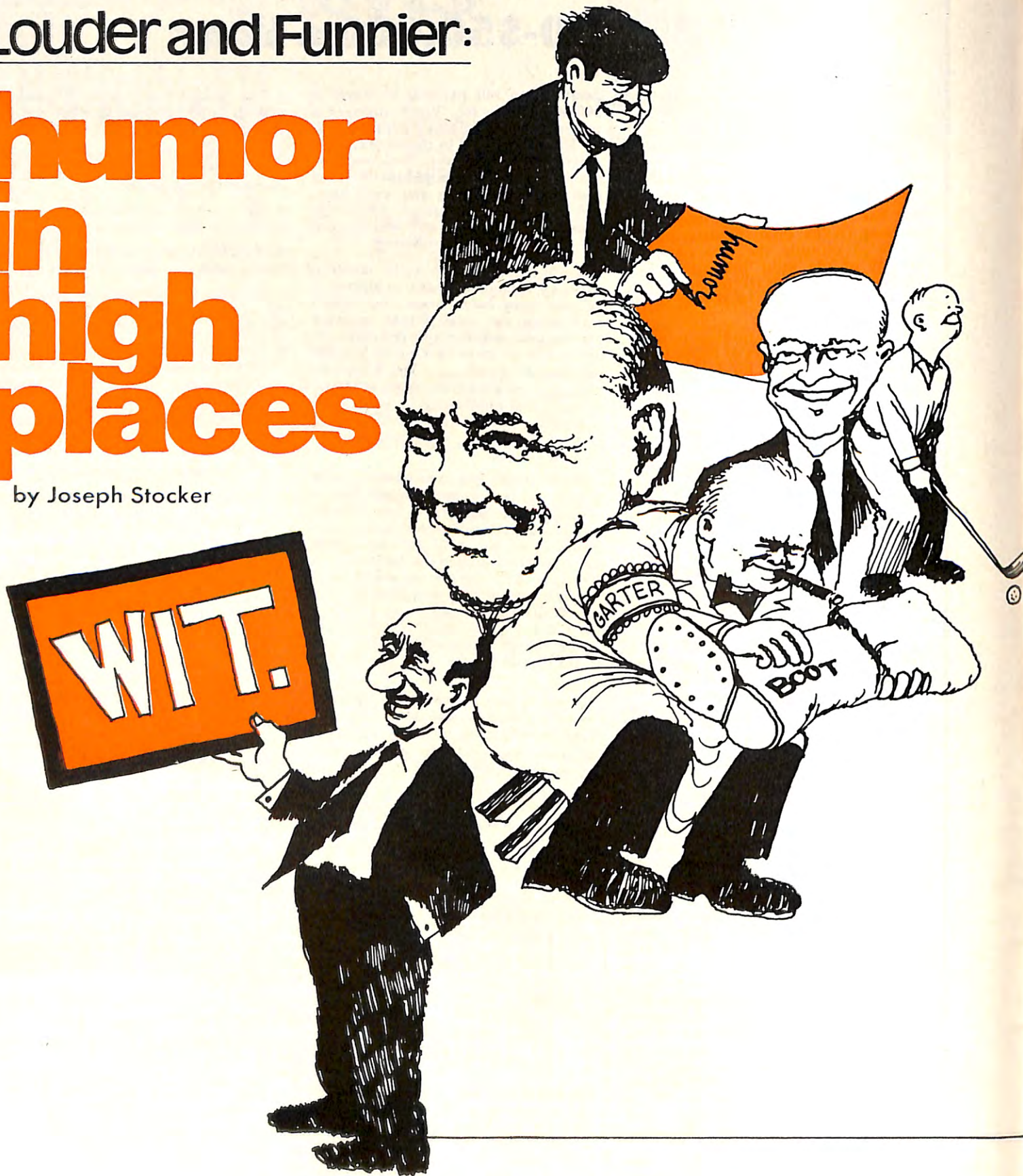

□ Humor is a familiar fixture of modern-day politics. Prominent politicians, from presidents on down, regard it as *de rigueur* to start a speech with a joke or a quip. The only trouble is, the humor is ritualistic and the jokes are usually supplied by paid gag-writers. "This is the age of tinned food; it has also become the age of tinned humor," says George Mikes, Hungarian lawyer turned journalist, in his book, *Laughing Matter*.

What's almost as rare in high places as candor and humility, in other words, is spontaneous humor. Well, yes, there's Morris Udall, but look what happened to him. As for those who made it to power, the picture isn't encouraging. Jimmy Carter smiles a lot but he isn't very funny. Neither was Ford. And there was little or nothing during the Nixon years for Nixon or his constituency to laugh about.

But it wasn't always thus. The historical record abounds with political and governmental leaders whose work was grim and earnest enough but who managed to keep a sense of humor through it all.

Consider England's great wartime prime minister, Winston Churchill, for instance. Few men had to assume more sobering responsibilities or face greater adversities. Yet the pixie persisted in him. Even in a personal rebuff he could see something funny, as when—despite his brilliant leadership of that beleaguered nation through World War II—the British voters kicked him out of office as soon as the shooting ended. As a kind of consolation prize, the King of England offered him a decoration known as the Order of the Garter. "Why," rumbled Churchill, "should I accept the Garter from His Majesty when his people have just given me the boot?"

It has even been suggested that Churchill's humor played a not inconspicuous role in Britain's very salvation during those parlous '40s. Says Robert Lewis Taylor, in his biography of the prime minister: "It was probably Churchill's capacity for having fun that won England allies in the war. A premier with the stolid phlegm of Baldwin, or the involuntary frostiness of Chamberlain, would have had difficulty persuading friends to such a forlorn cause. Churchill's hearty camaraderie drew influential visitors in to listen, partly because they were curious about the man...and Churchill wooed them with all the force of his roistering genius."

Humor of the Churchillian species—the low-key witticism—the downbeat repartee—the quiet crusher—seems to be firmly a part of the British governing tradition. Long before Churchill there was a brilliant prime minister named Benjamin Disraeli, who, when taunted by an opponent for his Jewishness, replied quietly, "Yes, I am a Jew, and when the ancestors of the right honorable gentleman were brutal savages in an unknown island, mine were priests in the temple of Solomon." It was in the same tradition that Robert Walpole got his comeuppance for saying to William Pitt: "Sir, you will either die on the gallows or of some unspeakable disease." Replied Pitt unhesitatingly: "That, my lord, depends upon whether I embrace your policies or your mistress."

Humor has been an equally important and effective part of the American political tradition. There was Illinois' Adlai Stevenson, who, though he lost twice to Dwight Eisenhower and thus never attained the presidency he sought so assiduously, will be remembered as one of the wittiest of politicians. And much of his wit was impromptu, as when he commented on the frequent rumors surfacing in the wake of his divorce that he was about to get married again, and always to a different woman. "They must think," he murmured, "that the plural of spouse is spice."

Stevenson buffs remember, too, the time when his home in Illinois—a beautiful edifice that he had just built—caught fire and burned to the ground. As he stood dolefully watching the blaze, a piece of flaming debris landed at his feet. He picked it up and lighted a cigarette with it. "At least," he remarked, "I'm still getting some use out of the house."

Stevenson's humor, said John Bartlow Martin in a contemporary biography he wrote of the former Illinois governor, "is of two kinds, both effective: crowd-warming jokes and integral wit related to the subject at hand. Much of it is at his own expense. He often assumes the role of an ineffectual hand-wringing lamb lost among wolves. His wit is dry. It works."

That dry Stevensonian wit interlarded his campaign speeches. He noted, in the course of one of them, that the platform from which Eisenhower addressed a Richmond, VA, audience had collapsed. "I'm glad the general wasn't hurt," said Stevenson. "But I wasn't surprised that it happened. I've been telling him for two months that nobody could stand on that platform."

Eisenhower, resolving to make political capital of Stevenson's penchant for wisecracks, attacked the latter as a candidate who preferred telling jokes to discussing issues. Stevenson responded with what has to be one of the nicer puns of 20th century politics.

"I refuse," he said straight-faced, "to conform to the Republican law of gravity."

But Ike himself, though an essentially serious man, managed to get off an occasional bon mot. Once, when he was playing golf at the Cherry Hills Club in Denver, another member of his foursome sliced an approach shot. To the player's horror, the wild ball hit the President squarely in the rear pocket. "Mr. President," cried the mortified golfer, "I hope you aren't hurt." Ike ruefully rubbed the place where the ball had hit. "That's where I carry my wallet," he said, "and this is the first time I've been touched there without being hurt!"

Some folks are surprised to learn that Calvin Coolidge, for all his celebrated dourness, was actually a man with a highly cultivated sense of humor. It tended to bubble up at odd times. Once, caught in the act of catnapping in the oval office midway through a business day, he opened his eyes and inquired dryly, "Is the country still here?" And when he was asked during his term in the Massachusetts legislature whether the people where he came from said, "A hen lays or a hen lies," he replied puckishly: "The people where I come from, sir, lift her up to see."

A former ambassador to Italy visited the White House while Coolidge was its occupant. When dinner ended, the President said he had something to show his guest and took him to another room. On the wall hung a portrait of Coolidge. The former ambassador considered it so very bad that he could think of nothing to say. They stood for a long and silent moment at the open doorway. Then Coolidge snapped off the light and closed the door. "So do I," he said.

On another occasion the White House was undergoing one of its intermittent piecemeal repairs. One day the architect and the contractor were in the attic examining the roof rafters and girders, and Coolidge joined them for a look. The architect called his attention to the fact that the timbers were the same ones that had been charred in the fire set by the British in the War of 1812. High time, he said, that they be replaced. The question was, should it be done with wood or the more expensive steel?

The President peered carefully at the charred wood, then turned to the contractor and said, "All right. Put in the steel beams and send the bill to the King of England."

Abraham Lincoln, like Calvin Coolidge, was an inherently grave and serious-minded person. But humor constituted as much a part of his makeup

as the wart near his nose. He sooner could disown his son, Tad, than resist the temptation to use a jest or a bit of drollery and thus relieve a moment of crisis, brighten his workaday life or unstuff a stuffed shirt.

His wasn't the flashing wit of a Churchill or a Disraeli. Rather it was broad humor, punctuated with jokes—many of them earthy—that he used to illustrate some point or other in an otherwise sober discussion. "I am reminded of a story," he would say, and then proceed to tell the story and, in the course of it, make his point more skillfully than it could have been made any other way. In short—as one writer has put it—Lincoln "used the power of laughter to strengthen the force of action."

A typical instance—one of a thousand or more—was when some friends of a certain outgoing governor called on Lincoln to urge appointment of the governor to an ambassador's post. Lincoln expressed a desire to oblige, but he explained that all the ambassadorships were presently occupied. "I am in the position of the young man," he said, "when his father told him he must cease his rakish life and take a wife. To which he answered: 'All right, Father, but whose wife shall I take?'"

Lincoln would have been the last to claim originality for his jokes. "You

speak of Lincoln stories," he said once to a visitor. "I don't think that is a correct phrase. I don't make the stories mine by telling them. I am only a retail dealer."

It remained for his Secretary of War, William H. Seward, to explain rather more precisely just what function was served by Lincoln's jokes. "Mr. Lincoln," he said, "never tells a joke for the joke's sake. They are like the parables of old—lessons of wisdom."

And so they were. And yet, along with his store of admittedly unoriginal jokes, Lincoln had a no less prodigious store of entirely original wit. He drew on it, as he drew on his jokes, to illustrate a point, appease an angry caller or disarm an opponent. But it would surface at other times as well, and for no other reason than that something struck Lincoln as funny and he just had to get it out. As when he received a dispatch from one of his generals during the early days of the Civil War when the North was losing more battles than it was winning. One of the problems, complained the general in his telegram, was that his horses were "fatigued." "Will you pardon me for asking," responded Lincoln, "what the horses of your army have done since the battle of Antietam that fatigues anything?"

(Continued on page 32)

THE JOY OF GIVING

Elks National Foundation

2750 Lakeview Avenue • Chicago, Illinois 60614



Pins and certificates were awarded to seven Escondido, CA, members during the lodge's recent National Foundation Night. Chm. Monty Syrig (left) and Co-chm. Harry Cowper (right) thanked their Brothers and lauded their generosity.

The outstanding achievements of two Lexington, MA, Brothers in supporting the National Foundation were recognized with a plaque presentation. Displaying the awards they received were PERs William Chemelli (left) and Carl Drevitson.



District Foundation Chm. Al Jones was on hand to present an honorary founder's certificate and congratulations to Astoria, OR, Lodge's first \$1,000 contributor, PER and Secy. Robert Gray.



Grand Lodge Officers And Committees For 1977-1978

GRAND EXALTED RULER

HOMER HUHNS, JR. (Mount Pleasant, Pennsylvania, Lodge No. 868)
Box 619, Latrobe, Pennsylvania (15650)

GRAND ESTEEMED LEADING KNIGHT

HAL M. RANDALL, Salem, Oregon, Lodge No. 336
2448 Crestview Drive, South (97302)

GRAND ESTEEMED LOYAL KNIGHT

DONALD D. BALVIN, Aberdeen, South Dakota, Lodge No. 1046
1820 Eisenhower Circle (57401)

GRAND ESTEEMED LECTURING KNIGHT

GARLAND F. GUILFOYLE (Newport, Kentucky, Lodge No. 273)
247 Blue Grass Avenue, Southgate, Kentucky (41071)

GRAND SECRETARY

STANLEY F. KOCUR (East Chicago, Indiana, Lodge No. 981)
2750 Lake View Avenue, Chicago, Illinois (60614)

GRAND TREASURER

GEORGE J. BALBACH (Queens Borough (Elmhurst), New York, Lodge No. 878)
34-05 80th Street, Jackson Heights, New York (11372)

GRAND INNER GUARD

CARL H. FERNSTRUM, Menominee, Michigan, Lodge No. 1755
1824-10th Avenue (49858)

GRAND TILER

MARTIN N. GRONVOLD, Mandan, North Dakota, Lodge No. 1256
1800 Monte Drive (58554)

GRAND ESQUIRE

DAN DAVIS (Van Nuys, California, Lodge No. 2028)
13201 Whistler Lane, Granada Hills, California (91344)

GRAND CHAPLAIN

REV. JOHN MOEDER, Manhattan, Kansas, Lodge No. 1185
Box 844 (66502)

SECRETARY TO GRAND EXALTED RULER

JAMES P. EBERSBERGER, Latrobe, Pennsylvania, Lodge No. 907
Box 619 (15650)

BOARD OF GRAND TRUSTEES

LEONARD J. BRISTOL (Chairman), Saranac Lake, New York, Lodge No. 1508
47 Baker Street (12983)
H. FOSTER SEARS (Vice-Chairman), Macomb, Illinois, Lodge No. 1009
55 North Yorktown (61455)
FRANK GARLAND (Approving Member), (Centralia-Chehalis, Washington,
Lodge No. 2435) Box 615, Centralia, Washington (98531)
A. LEWIS HEISEY (Secretary), (Middletown, Pennsylvania, Lodge No. 1092)
244 South Market Street, Elizabethtown, Pennsylvania (17022)
ROBERT GRAFTON (Home Member), (North Palm Beach, Florida, Lodge No.
2069) Box 904, West Palm Beach, Florida (33402)
EDWARD M. SCHLIETER (Pension Member), New Braunfels, Texas, Lodge No.
2279) Box 311, Kerrville, Texas (78028)
LARRY L. MCBEE (Building Applications-East), New Lexington, Ohio, Lodge
No. 509, Box 567, 106 South Main Street (43764)
Area 1: Connecticut, Maine, Massachusetts, New Hampshire, New
York, Rhode Island, Vermont
Area 2: Maryland-Delaware-District of Columbia, New Jersey, Penn-
sylvania, West Virginia
Area 3: Alabama, Arkansas, Canal Zone, Florida, Georgia, Kentucky,
Louisiana, Mississippi, Missouri, North Carolina, Puerto Rico, South
Carolina, Tennessee, Virginia
Area 4: Indiana, Michigan, Ohio
MARVIN M. LEWIS (Building Applications-West), Brawley, California, Lodge
No. 1420, 522 Main Street (92227)
Area 5: Illinois, Iowa, Minnesota, North Dakota, Wisconsin
Area 6: Colorado, Kansas, Montana, Nebraska, New Mexico,
Oklahoma, South Dakota, Texas
Area 7: Arizona, California, Guam, Hawaii, Nevada, Philippine
Islands
Area 8: Alaska, Idaho, Oregon, Utah, Washington, Wyoming

GRAND FORUM

ALEX M. HARMAN, JR. (Chief Justice), Pulaski, Virginia, Lodge No. 1067
Box 1438 (24301)
EDWARD C. ALEXANDER, Great Falls, Montana, Lodge No. 214
Box 1744 (59403)

WILLIAM J. STEINBRECHER (New Hyde Park, New York, Lodge No. 2107)
500 Old Country Road, Garden City, New York (11530)
SIDNEY J. NICHOLSON, Florence, Oregon, Lodge No. 1858
Box 146 (97439)
ROBERT R. WEBB (Santa Ana, California, Lodge No. 794)
1427 Bank of America Tower, One City Boulevard, West; Orange,
California (92668)

COMMITTEE ON JUDICIARY

EDWARD W. CONNOLLY (Chairman), Livingston, New Jersey, Lodge No.
1855, 35 North Livingston Avenue (07039)
States: MD, DE, DC, NJ, PA, PR, WV
RAYMOND V. ARNOLD, Jackson, Michigan, Lodge No. 113
Box 570 (49204)
States: IN, KY, MI, OH, VA
EUGENE F. COSTELLO, Denver, Colorado, Lodge No. 17
750 Petroleum Club Building, 110-16th Street (80202)
States: CZ, CO, NM, OK, TX, WY
ROBERT J. SABIN, Arlington Heights, Illinois, Lodge No. 2048
1040 South Arlington Heights Road (60005)
States: IL, IA, KS, MN, NE, ND, SD, WI
BERTIL E. JOHNSON, Tacoma, Washington, Lodge No. 174
2747 Soundview Drive, West (98466)
States: AK, ID, MT, OR, UT, WA
LEROY J. KOOS, Culver City, California, Lodge No. 1917
Box 706 (90230)
States: AZ, CA, GU, HI, NV, RP
DANIEL B. TAMMANY, St. Louis, Missouri, Lodge No. 9
6122 McPherson Avenue (63112)
States: AL, AR, FL, GA, LA, MS, MO, NC, SC, TN
ALFRED J. MATTEI, Worcester, Massachusetts, Lodge No. 243
313 Park Avenue (01609)
States: CT, ME, MA, NH, NY, RI, VT

AMERICANISM COMMITTEE

JAMES W. DAMON (Chairman), (John Day, Oregon, Lodge No. 1824)
Box 38, Mt. Vernon, Oregon (97865)
DOMINIC P. DULULIO, Leominster, Massachusetts, Lodge No. 1237
19 Wheeler Street (01453)
ROBERT L. SMITH (McAlester, Oklahoma, Lodge No. 533)
Box 316, Indianola, Oklahoma (74442)
ALEX R. BRADY, Monongahela, Pennsylvania, Lodge No. 455
501 Jackson Street (15063)
M. J. HAACK, Bemidji, Minnesota, Lodge No. 1052
2508 Calihan Avenue (56601)
YUBI G. SEPAROVICH, Sacramento, California, Lodge No. 6
Box 1556 (95807)
GEORGE B. WALKER (Willoughby, Ohio, Lodge No. 1924)
6401 Seneca Trail, Mentor, Ohio (44060)
J. W. WORTMAN, JR., Albany, Georgia, Lodge No. 713
2027 Whispering Pines Road (31705)

AUDITING AND ACCOUNTING COMMITTEE

H. E. STALCUP (Chairman), Storm Lake, Iowa, Lodge No. 1636
Bel Air Beach, Storm Lake, Iowa (50588)
Area No. 5: IL, IA, MN, ND, WI
G. CLIFFORD WHITTLE, Seattle, Washington, Lodge No. 92
Suite 1200, Plaza 600 (98101)
Area No. 8: AK, ID, OR, UT, WA, WY
ROBERT C. GRANT, Cullman, Alabama, Lodge No. 1609
1604 Catoma Drive, N.E. (35055)
Area No. 3: AL, AR, CZ, FL, GA, KY, LA, MS, MO, NC, PR, SC,
TN, VA
JOHN J. CUNNINGHAM, Butte, Montana, Lodge No. 240
800 South Montana Street (59701)
Area No. 6: CO, KS, MT, NE, NM, OK, SD, TX
JOSEPH M. MATTIAS, West Warwick, Rhode Island, Lodge No. 1697
1499 Main Street (02893)
Area No. 1: CT, ME, MA, NH, NY, RI, VT
NORMAN M. LOPEZ, Santa Monica, California, Lodge No. 906
327 Wilshire Boulevard-Suite 220 (90401)
Area No. 7: AZ, CA, GU, HI, NV, RP
HENRY H. DEMBO (Washington, D.C., Lodge No. 15)
8502 Postoak Road, Potomac, Maryland (20854)
Area No. 2: DE, DC, MD, NJ, PA, WV
JAMES L. DOMPIERRE, Negaunee, Michigan, Lodge No. 1116
1008 Pine Street (49866)
Area No. 4: IN, MI, OH

COMMITTEE ON CREDENTIALS

CARL R. QUESNEL (Chairman), Montpelier, Vermont, Lodge No. 924
22 College Street (05602)
ART M. OLSON, Ely, Nevada, Lodge No. 1469
9 Elysium Drive (89301)
C. NEWT JONES (Cocoa, Florida, Lodge No. 1532)
325 Kenzel Ct., Merritt Island, Florida (32952)
A. J. BEELER, McMinnville, Oregon, Lodge No. 1283
Box 537 (97128)
PAUL W. BRUBAKER, Lancaster, Pennsylvania, Lodge No. 134
1914 Millersville Pike (17603)

JAMES G. FRANEY, SR., Eau Claire, Wisconsin, Lodge No. 402
433 Garfield Avenue (54701)
P. W. LOVELAND, SR., Jeffersonville, Indiana, Lodge No. 362
111 East Riverside Drive (47130)
HOWARD W. NUNEZ, Albuquerque, New Mexico, Lodge No. 461
3020 Jardin Plaza, Northeast (87110)

LODGE ACTIVITIES COMMITTEE

CHARLES E. MCGINLEY (Chairman), (Oakmont, Pennsylvania, Lodge No. 1668) 220 Lansdowne Drive, Verona, Pennsylvania (15147)
PETER T. AFFATATO, Hicksville, New York, Lodge No. 1931
Box 32-57 North Broadway (11802)
ROBERT J. McLAIN, (Pasadena, California, Lodge No. 672)
841 Volante Drive, Arcadia, California (91006)
JAMES R. KENNEY, Granite City, Illinois, Lodge No. 1063
1105 Verde Drive, Apartment D, Colorado Springs, Colorado (80910)
GEROLD F. LAMERS, Spokane, Washington, Lodge No. 228
201 Medical Center Building, 820 South McClellan (99204)
JOHN D. SULLIVAN, Southern Pines, North Carolina, Lodge No. 1692
290 Midland Road (28387)
MAURICE I. GARDNER, Grand Junction, Colorado, Lodge No. 575
Box 1769 (81501)
STANLEY O. MASCOE, Indianapolis, Indiana, Lodge No. 13
2531 Union Street (46225)

NEW LODGE COMMITTEE

ROBERT T. FLYNN (Chairman), Sterling, Illinois, Lodge No. 1218
2203-4th Avenue, R. R. #3 (61081)
GEORGE C. FRICK (Tenafly, New Jersey, Lodge No. 2271)
17 Glen Carl, Upper Saddle River, New Jersey (07458)
THOMAS E. JONES (Gateway (Portland), Oregon, Lodge No. 2411)
2136 N. E. 134th Place, Portland, Oregon (97230)
EARL W. NOWELL, Fresno, California, Lodge No. 439
1646 North Pacific Avenue (93705)
LEWIS L. NURNBERGER (Manistee, Michigan, Lodge No. 250)
849 Thomtree Boulevard, Jackson, Michigan (49203)
ALVIN A. EHRLICH, Orlando, Florida, Lodge No. 1079
Box 1423 (32802)
RAYMOND R. FRIEDERICH (Chanute, Kansas, Lodge No. 806)
Route #2, Box 60A, Erie, Kansas (66733)
ROBERT E. SMITH, Nashua, New Hampshire, Lodge No. 720
31 Charlotte Avenue (03060)

RITUALISTIC COMMITTEE

DUNCAN MCPHERSON (Chairman), (Ballard (Seattle), Washington, Lodge No. 827) 11500-15th, N.E., #207, Seattle, Washington (98125)
FRED A. PADOVANO, Kearny, New Jersey, Lodge No. 1050
74 Patterson Avenue (07032)
DALE W. BLANTON, San Rafael, California, Lodge No. 1108
269 Blackstone Drive (94903)
TED CALLICOTT, Paris, Tennessee, Lodge No. 816
Tyson Avenue (38242)
JAMES W. ANDERSON, Kearney, Nebraska, Lodge No. 984
2300-5th Avenue (68847)
JOHN J. LEDOSQUET, Williston, North Dakota, Lodge No. 1214
Box 419 (58801)
RAYMOND T. ENGLISH, Plattsburgh, New York, Lodge No. 621
Box 598 (12901)
ROBERT J. LACE, Niles, Michigan, Lodge No. 1322
322 Michigan Street (49120)

STATE ASSOCIATIONS COMMITTEE

RICHARD W. SQUIRES (Chairman), (Dover, New Jersey, Lodge No. 782)
118 East Mountain Road, Sparta, New Jersey (07871)
IRWIN H. STIPP, Springfield, Illinois, Lodge No. 158
Box 2162 (62705)
ROBERT L. EARNEST, Russell, Kansas, Lodge No. 1715
Box 72 (67665)
NORMAN P. O'BRIEN (South Miami, Florida Lodge No. 1888)
1525 Mercado, Coral Gables, Florida (33146)
WILLIAM H. WARDEN, Lebanon, Oregon, Lodge No. 1663
789 Ralston Drive (97355)
J. FLOYD BELDON, Seymour, Indiana, Lodge No. 462
Box 303, 300 West Second Street (47274)
MICHAEL J. DEIR, Tucson, Arizona, Lodge No. 385
5447 East 5th Street, Suite 111 (85711)
SEYMOUR NATHANSON, Portland, Maine, Lodge No. 188
35 Coyle Street (04101)

YOUTH ACTIVITIES COMMITTEE

JOHN T. TRAYNOR (Chairman), Devils Lake, North Dakota, Lodge No. 1216
Box 838 (58301)
B. J. BYBEE, Idaho Falls, Idaho, Lodge No. 1087
1430 Antares Drive (83401)
EDWIN J. MALEY, (New Haven, Connecticut, Lodge No. 25)
123 Ardmore Street, Hamden, Connecticut (06517)
WILLIAM H. ROSEN, Williamson, West Virginia, Lodge No. 1408
Box 2197 (25661)
W. K. RYNEARSON, (Ainsworth, Nebraska, Lodge No. 1790)
Box 422, Broken Bow, Nebraska (68822)
RALPH W. CLEMENTS, Lake City, Florida, Lodge No. 893
1959 Castle Heights Drive (32055)
NICK M. KOVIC, Warren, Ohio, Lodge No. 295
1105 Willard, Southeast (44484)
JOE D'ANGELO, Phoenix, Arizona, Lodge No. 335
3321 West Turney (85017)

ELKS NATIONAL "HOOP SHOOT"® FREE THROW CONTEST

GERALD L. POWELL (National Director), Peru, Indiana, Lodge No. 365
Box 520 (46970)

PARDON COMMISSION

ALEX M. HARMAN, JR. (Chairman), Pulaski, Virginia, Lodge No. 1067
Box 1438 (24301)
EDWARD W. CONNOLLY, Livingston, New Jersey, Lodge No. 1855
35 North Livingston Avenue (07039)
WILLIAM H. WEALEY (Commissioner), (Buckhead (Atlanta), Georgia,
Lodge No. 1635) 170 Dalrymple Road, Atlanta, Georgia (30328)

ELKS NATIONAL MEMORIAL AND PUBLICATION COMMISSION

WADE H. KEPNER (Chairman), Wheeling, West Virginia, Lodge No. 28
1308 Chapline Street (26003)

R. LEONARD BUSH (Vice-Chairman), (Inglewood, California, Lodge No. 1492) Box 238, El Toro, California (92630)
EDWARD W. McCABE (Treasurer), Nashville, Tennessee, Lodge No. 72
Box 124 (37221)
RAYMOND C. DOBSON (Secretary), Minot, North Dakota, Lodge No. 1089
Box 1150 (58701)
ROBERT E. BONEY (Assistant Secretary-Assistant Treasurer)
Las Cruces, New Mexico, Lodge No. 1119
Drawer KK (88001)

ELKS NATIONAL FOUNDATION TRUSTEES

JOHN L. WALKER (Chairman), Roanoke, Virginia, Lodge No. 197
Box 720 (24004)
WILLIAM A. WALL (Vice-Chairman), West Palm Beach, Florida, Lodge No. 1352, Box 986 (33402)
HORACE R. WISELY (Secretary), Salinas, California, Lodge No. 614
Box 2117 (93902)
E. GENE FOURNACE (Treasurer), (Newark, Ohio, Lodge No. 391)
Box 468, Canton, Ohio (44701)
ROBERT A. YOTHERS (Assistant Secretary), Seattle, Washington, Lodge No. 92, Box 70307 (98107)
GLENN L. MILLER (Assistant Treasurer), Logansport, Indiana, Lodge No. 66
Box 118 (46947)
WILLIS C. McDONALD, (New Orleans, Louisiana, Lodge No. 30)
Box 89, Slidell, Louisiana (70459)

ELKS NATIONAL SERVICE COMMISSION

WILLIAM J. JERNICK (Chairman-Treasurer), Nutley, New Jersey, Lodge No. 1290, 44 Alexander Avenue (07110)
GEORGE I. HALL (Vice-Chairman), (Lynbrook, New York, Lodge No. 1515)
8 Inner Circle, Scottsdale, Arizona (85258)
ROBERT C. PRUITT (Secretary), (Buckhead (Atlanta), Georgia, Lodge No. 1635) 3174 Peachtree Drive, N.E., Atlanta, Georgia (30305)
RONALD J. DUNN, Oneida, New York, Lodge No. 767
112 Farrier Avenue (13421)
FRANK HISE, Corvallis, Oregon, Lodge No. 1413
Box 1047 (97330)
E. GENE FOURNACE, (Newark, Ohio, Lodge No. 391)
Box 468, Canton, Ohio (44701)
FRANCIS M. SMITH, Sioux Falls, South Dakota, Lodge No. 262
Box 1700 (57101)

CONVENTION COMMITTEE

GEORGE I. HALL (Chairman), (Lynbrook, New York, Lodge No. 1515)
8 Inner Circle, Scottsdale, Arizona (85258)
ROBERT C. PRUITT (Buckhead (Atlanta), Georgia, Lodge No. 1635)
3174 Peachtree Drive, N.E., Atlanta, Georgia (30305)
ROBERT E. BONEY, Las Cruces, New Mexico, Lodge No. 1119
Drawer KK (88001)
GLENN L. MILLER, Logansport, Indiana, Lodge No. 66
Box 118 (46947)
ROBERT A. YOTHERS, Seattle, Washington, Lodge No. 92
Box 70307 (98107)

ADVISORY COMMITTEE

RONALD J. DUNN (Chairman Emeritus), Oneida, New York, Lodge No. 767
112 Farrier Avenue (13421)
FRANCIS M. SMITH (Chairman), Sioux Falls, South Dakota, Lodge No. 262
Box 1700 (57101)
R. LEONARD BUSH (Vice-Chairman), (Inglewood, California, Lodge No. 1492) Box 238, El Toro, California (92630)
ROBERT C. PRUITT (Secretary), (Buckhead (Atlanta), Georgia, Lodge No. 1635) 3174 Peachtree Drive, N.E., Atlanta, Georgia (30305)
WADE H. KEPNER, Wheeling, West Virginia, Lodge No. 28
1308 Chapline Street (26003)
GEORGE I. HALL (Lynbrook, New York, Lodge No. 1515)
8 Inner Circle, Scottsdale, Arizona (85258)
WILLIAM J. JERNICK, Nutley, New Jersey, Lodge No. 1290
44 Alexander Avenue (07110)
JOHN L. WALKER, Roanoke, Virginia, Lodge No. 197
Box 720 (24004)
HORACE R. WISELY, Salinas, California, Lodge No. 614
Box 2117 (93902)
WILLIAM A. WALL, West Palm Beach, Florida, Lodge No. 1352
Box 986 (33402)
RAYMOND C. DOBSON, Minot, North Dakota, Lodge No. 1089
Box 1150 (58701)
ROBERT E. BONEY, Las Cruces, New Mexico, Lodge No. 1119
Drawer KK (88001)
EDWARD W. McCABE, Nashville, Tennessee, Lodge No. 72
Box 124 (37221)
FRANK HISE, Corvallis, Oregon, Lodge No. 1413
Box 1047 (97330)
GLENN L. MILLER, Logansport, Indiana, Lodge No. 66
Box 118 (46947)
E. GENE FOURNACE (Newark, Ohio, Lodge No. 391)
Box 468, Canton, Ohio (44701)
ROBERT A. YOTHERS, Seattle, Washington, Lodge No. 92
Box 70307 (98107)
GERALD STROHM, Fresno, California, Lodge No. 439
Box 8127 (93727)
WILLIS C. McDONALD (New Orleans, Louisiana, Lodge No. 30)
Box 89, Slidell, Louisiana (70459)
GEORGE B. KLEIN, Lincoln, Nebraska, Lodge No. 80
Box 83086 (68501)

GRAND LODGE AGENCIES

THE ELKS MAGAZINE, 425 West Diversey Parkway, Chicago, Illinois (60614)
JOHN R. RYAN, Publisher/General Manager
ELKS NATIONAL FOUNDATION, 2750 Lake View Avenue, Chicago, Illinois
(60614)
NELSON E. W. STUART, Executive Director
ELKS NATIONAL SERVICE COMMISSION, 370 Lexington Ave.-Room 715,
New York, NY (10017)
BRYAN J. MCKEOGH, Director
ELKS NATIONAL CONVENTION COMMITTEE, 370 Lexington Ave.-Room 715,
New York, NY (10017)
BRYAN J. MCKEOGH, Director
PUBLIC RELATIONS DEPARTMENT (Now under the Grand Secretary's Office)
2750 Lake View Avenue, Chicago, Illinois (60614)
ROBERT E. SCONCE, Assistant to Grand Secretary and PR Director
ELKS NATIONAL HOME, Bedford, Virginia (24523)
DORAL E. IRVIN, Executive Director

YOU AND RETIREMENT

by Grace W. Weinstein

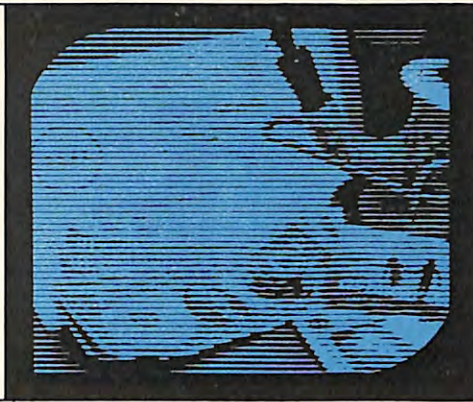

WHEN TO RETIRE

When should you retire? 65? 70? 55? never? As this is being written Congress is grappling with the question of forbidding mandatory retirement before the age of 70 in both federal jobs and private industry. The political question may be decided by now, but some issues remain:

- ⊙ Who should decide when an individual retires? The employer? The government? The individual worker?
- ⊙ Should there be uniform criteria for establishing a retirement age? What should those criteria be?
- ⊙ How is the best interest of society served? The best interest of the individual? Can both be met?
- ⊙ What do people, real live individual people, want to do? When do you want to retire?

Retirement at an established time is even newer than retirement as a phase of life. Sixty-five was picked as a good age for benefits to start when Social Security was established in 1935, largely because Bismarck had decided some years earlier that it was a good age for German social benefits to begin—and there are those who suggest that Bismarck picked 65 for his social programs because so few workers then lived to that ripe old age.

But employer-determined and mandated age of retirement, whether 65, 55 or 70, is increasingly under attack. Representative Claude Pepper of Florida has been campaigning for years against mandatory retirement policies as a form of discrimination; this year his bill looks as if it may pass. The American Medical Association asserts that enforced idleness leads to both physical and mental deterioration. And, perhaps the most pungent argument: the Social Security system is running short of funds. One way to make the funds last longer is to start payouts later; Commerce Secretary Juanita M. Kreps announced in July that the Carter Administration is discussing the possibility of withholding payment of full benefits until recipients reach age 68. Such a move would, of course, encourage people to work longer.

Yet the larger question remains: should government, or business, establish any age at which retirement must take place? Business seems to think so; 65 percent of the business executives surveyed in June, 1977, by the consulting firm of William M. Mercer, Inc., favor mandatory retirement. Some of the reasons, cited by J. Roger O'Meara of the Conference Board:

In a time of slowed economic growth and unemployment, older workers must give up their jobs to make room for younger workers. At all times, furthermore, retirement keeps the channels for promotion open, thus motivating younger employees. Calculations of pension benefits are easier when employers can predict retirement dates accurately. And, on humanistic grounds, many employers claim that mandatory retirement, by treating all employees alike, avoids the problems which can arise if any employer has to tell a particular employee that he or she is no longer competent. Business is not alone in its position; labor unions, by and large, agree. The AFL-CIO says that when mandatory retirement is part of a union contract it is not forced but voluntary and should be left alone.

On the other side of the coin, many people claim that mandatory retirement puts them "on the shelf" at a time when they are healthy and vigorous and eager to continue working. Many older people need and want both the income from employment and the sense of usefulness that employment provides.

Yet, at the same time, many other employees are only too delighted to retire and there is some fear that eliminating mandatory retirement might force people to stay on the job when they no longer wish to work. There are two parallel but conflicting trends: Along with the movement toward abolishing mandatory retirement there is another grass-roots movement toward earlier and earlier retirement. Where pension benefits are adequate, increasing numbers of workers are choosing to retire early.

What do people do when they "retire" at 50? Some go fishing, or travel, or catch up on long-neglected household tasks. Some go to school. Some volunteer, serving worthwhile causes ranging from a neighborhood hospital to the Peace Corps.

How do you view retirement? Are you looking forward to it? Or dreading it? What specific plans are you making for the way you'll spend your days? If you've already retired, what do you know now that you wish you had known in advance? I'll be interested. Write to Grace W. Weinstein, c/o The Elks Magazine, 425 West Diversey Parkway, Chicago, Illinois 60614. Replies of general interest will be reported in future columns.

CHRISTMAS SPECIAL!

The Halvorfold

Loose-leaf Pass Case, Billfold Card Case. Note Exclusive features. Read Special Offer below

Name, address and any Fraternal Emblem in 25K Gold FREE

Billfold With Secret Money Compartment

Card Pocket

Card Pocket

8-pass capacity replaceable
12 Pass 25¢ Add'l
16 Pass 50¢ Add'l
20 Pass 75¢ Add'l

Exclusive Loose-Leaf Device
BLACK OR BROWN WATER BUFFALO

Lodge No. under inside emblem 75¢ add'l.
Lodge No. with City under inside emblem \$1.25 add'l.
Social Security No. 75¢ add'l.

Outside closing Flap means more Security

"CUSTOM MADE FOR ELKS"

"NOW in its 51st year" —The HALVORFOLD billfold, pass case, card case. Just what every Elk needs. No fumbling for passes, just unsnap the Halvorfold and each pass shows under separate transparent face, protected from dirt and wear. Ingenious loose leaf device shows 8, 12, 16 or 20 passes, cards or photos. Three card pockets, extra size bill compartments and secret flap to cover large bills. Only genuine leathers are used; tough durable but soft in texture. Nylon stitched.

Free Examination!

Send No Money—Pay No C.O.D.

Means exactly what it says. No strings. Mail coupon. Halvorfold comes by return mail. Examine it carefully. Slip in passes and cards. See how handy it is. Show it to your friends and note their admiration. Compare it with other cases at more money. We normally ship parcel post. (Postpaid on cash orders) This takes up to 4 weeks for delivery. However if you wish faster delivery please note additional charges below. REMEMBER: Money back if not satisfied.

Halvorsen, P.C.M., 4868 Victor St., Jacksonville, Fla. 32207

Dept. 128

Send the HALVORFOLD with goldstamping as below. If I decide to keep it I will send check at once. If not, I will return it within three days for full refund. Goldstamped with name, address and any fraternal emblem free. If you send cash with order, we ship postpaid. Parcel Post.

25K Gold Inside Emblem: Please Print

Name: _____

Address: _____

S. S. NO. _____ PLEASE USE ZIP CODE _____

PLEASE CHECK HERE:

<input type="checkbox"/> Black Buffalo \$12.00	<input type="checkbox"/> Bro. Buffalo \$12.00
<input type="checkbox"/> 12 Pass 25¢ Add'l	<input type="checkbox"/> 16 Pass 50¢ Add'l
<input type="checkbox"/> 20 Pass 75¢ Add'l	<input type="checkbox"/> Elk Emblem Inside FREE
<input type="checkbox"/> Elk Emblem Outside 75¢ Add'l	
<input type="checkbox"/> Lodge No. Under Inside Emblem 75¢ Add'l	
<input type="checkbox"/> Social Security Number 75¢ Add'l	
<input type="checkbox"/> First class .60 add'l	

by Jerry Hulse

The ol' Miss' hasn't changed much since Mark Twain . . . but the travelin' . . . ah what a difference

Rolling on the



Mississippi...



□ Tired of cruising the Caribbean, haggling with the merchants of Hong Kong and promenading through Picadilly? We've a suggestion: How about a slow boat to Natchez? (No jet lag, no city pressures, no big crowds.) In case you hadn't heard, nostalgia's being sold down the river—heaps of old-time Dixieland, ragtime and Southern home cooking, all of it accompanied by the lonely whistle of a paddle-wheeler and the soft voice of the muddy ol' Miss'. The *slow boat* is the slick new \$24 million Mississippi Queen and her route of escape is Natchez-to-New Orleans.

The new Queen is the sister of the old Delta Queen. Only there's a huge difference: instead of a Victorian lounge and rustic cabins, the Mississippi Queen is as comfortable as an ocean liner cruising the Caribbean. Capable of carrying up to 400 passengers, she's equipped with elevators, a sauna, a swimming pool, a motion picture theater, a beauty salon and a gift shop. Seeing her float along the Mississippi, Huckleberry Finn would stare in disbelief. Imagine, a steamboat with air conditioning, telephones, carpeted staircases and three bars. Still the Mississippi Queen generates a certain nostalgia, a recollection of another time and less-hurried

days. In a lofty bar, passengers sip mint juleps and stare down while her huge paddle wheel stirs up a muddy wake. Eddie Bayard blows the sweetest cornet this side of Bourbon Street while Vic Tooker strums his banjo and shock waves from a calliope crash head-on against the riverbank.

As for the ol' Miss', it hasn't really changed a great deal since Mark Twain's time. The elms, cottonwoods, cypress and sycamores still line its banks, dark places where a boy can build himself a raft or have the wits scared out of him by strangers. It's as muddy as it ever was, with logs, tree branches and catfish and a million seeds that float downriver to grow and become trees and eventually to float away themselves one day. Overhead a cornflower sky is laced with white clouds and along the riverbanks youngsters fish and play, much as Huck Finn did.

It's a scene that takes passengers aboard the Mississippi Queen back to another century. While the Queen is as up to date inside as the QE 2, outside she looks for all the world like an old 19th-century riverboat. She's the first overnight paddle-wheel steamboat to be built in America in 50 years, and her captain is as much of the Mississippi as the tides themselves.

It's the same with Vic Tooker, the banjoist who fills in at the steam calliope, pumping out near-forgotten melodies: "Sailing Away on the Henry Clay," "Floating Down to Cotton Town" and "Mississippi Mud." Tooker comes from a family of river folks. His great-grandfather piloted the old Lizzie Castle and grandpa Victor Tooker strummed the banjo on the Goldenrod. Tooker sports sleeve garters, a string tie and a straw hat. He's happy where he is. He wants to die on the river—just like his daddy did. Daddy Guy. He and Daddy Guy and his mother—she's still part of the act—performed together as a team.

The Mississippi Queen is a floating stage for the reincarnation of other characters who sailed the river during the 1800s. Step right up and meet Bodine Jackson Balasco, billed as "the last of the riverboat gamblers." It's a handle he gave himself. Actually, he's a 27-year-old UCLA graduate who decided to become an entertainer, a riverboat man who hypnotizes his audience with such old swindles as the shell game and three-card Monte. Bodine Jackson Balasco is recognized by his diamond-studded cuff links, the ruffled shirt, the polished manner, the dazzling smile and, as he immodestly puts it, his way with the "hundred-dollar words." Billed as the "only honest cheat you'll ever meet," he performs sleight-of-hand feats and regales passengers with tales of slave dealers, courtesans, murderers, ad-

venturers and speculators during a period when cotton was still king and hundreds of riverboats cruised the Mississippi.

Balasco signed on after the new Queen was launched in Cincinnati on the Ohio River, which is also part of the paddle-wheeler waterway. Dixieland bands played for crowds gathered at Yeatman's Cove Park and crew members stole down the gangway looking like castoffs from some 1800s theatrical production. Rep. Lenor K. Sullivan called out, "God save the Queen" and the new riverboat nearly blew her stack. It was a rootin', tootin' auspicious beginning that soon fizzled as the Queen lost her head of steam. Someone had goofed with the power plant. She was so slow on her maiden voyage that it took two towboats to assist her the final 200 miles. After having her paddle wheel refashioned, she took to the river again; now she's proving to passengers how blissful life is on a slow boat to Natchez.

Likely none of this would have occurred had it not been for a slip of a woman named Betty Blake. She helped save the queen. Not the Mississippi Queen but the beloved and venerable Delta Queen. Remember the uproar? Americans everywhere joined the campaign to keep her from the scrap heap after she was threatened by the Safety at Sea Law. Built in Scotland in 1926 of teak and other rare woods, she was considered a fire hazard because of her wooden superstructure. Betty Blake had two adversaries—Congress and the Coast Guard. She countered by marshaling armies of steamboat lovers. She lobbied in Washington while they wrote letters. Congress was inundated. So was the Coast Guard. Meanwhile Blake & Co. spent \$5 million overhauling the

Delta Queen to satisfy safety rules. She appeared on TV and radio shows and ushered in a campaign in Hannibal, Missouri, to save her precious queen. This was Mark Twain territory and the entire town turned out. Even Becky Thatcher, or a reasonable facsimile.

Betty Blake pushed a wheelbarrow filled with petitions to the steps of Congress. During her fight she mustered love and hate alike. Mostly it was love. Country singer Johnny Cash wrote a song about the Queen. Other entertainers joined the act. By now the Delta Queen has had six reprieves. Her last one will keep her cruising until November 1, 1983.

Now with the new Mississippi Queen in action, crowds are journeying between New Orleans and Natchez.

In Natchez passengers take time out to tour the city's magnificent old antebellum homes. For nearly half a century ladies in hoop skirts and gentlemen in planter suits have guided visitors through nearly three dozen pre-Civil War mansions in a month-long springtime observance. Natchez's annual Spring Pilgrimage was ushered in during the Depression years to raise money for maintaining the town's historic old homes. This year the pleasant Mississippi village presented a curtain call, offering the same show for another two weeks in October.

As the oldest town along the Mississippi, Natchez was founded in 1716. During the mid-1800s more than half of America's millionaires accumulated their wealth in the region. In the promising years of the 19th century, plantations produced fortunes. Cotton was king and the wealth was beyond imagination. The plantations spanned hundreds of acres, but with the end of the Civil War the wealth vanished—along with the

Huck Finn would stare in disbelief . . . she's as comfortable as an ocean liner

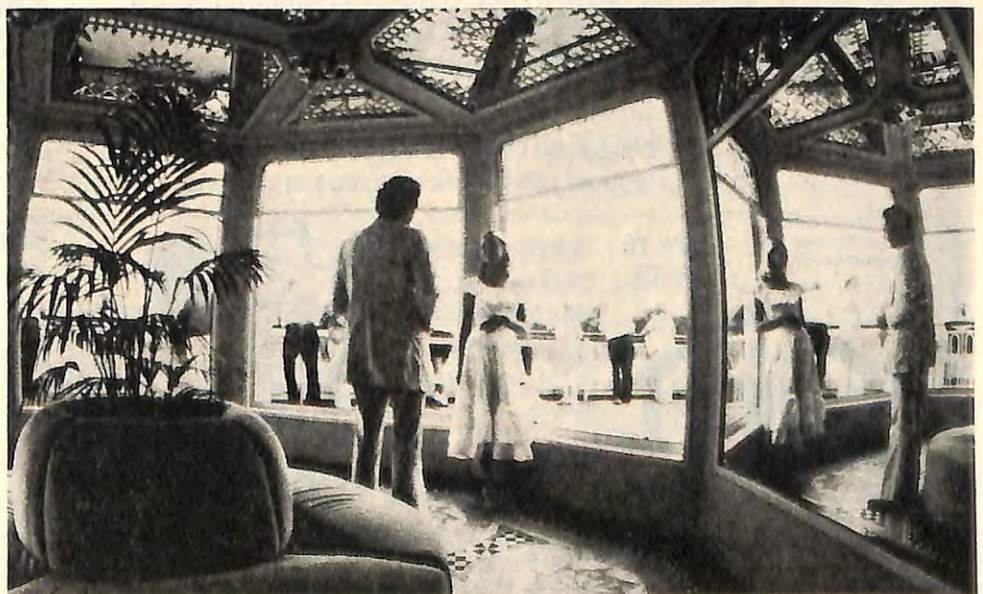

demand for cotton. Behind stood dozens of magnificent antebellum homes—homes filled with ghosts and memories. Lace curtains rotted at the windows. Shutters rattled in the wind. Natchez, a one-time center of culture, was dying, and for the remainder of the century it slumbered. Although Union forces occupied Natchez during the siege of Vicksburg, General Grant ordered his troops to spare its buildings. As a result, more than 200 antebellum structures still stand while Natchez preaches to the nation that "this is where the Old South still lives."

Dividing their forces into two groups, the ladies of Natchez formed the Natchez Garden Club and the Pilgrimage Garden Club. Together they share a single purpose: the preservation of the city's great antebellum mansions. Serving as headquarters for the Pilgrimage Club is Stanton Hall, a princely, 119-year-old residence whose grounds occupy an entire city block. Beyond the garden the ladies operate a bar and restaurant—siphoning off goodly profits for the restoration of other great homes in Natchez.

Meanwhile, the Natchez Garden Club does its act in Connelly's Tavern, a misnomer since it's as dry as a church social on the sabbath. The fact is Connelly's Tavern is a former hostelry that was rescued from collapse and restored

by the ladies to its former glory. One of the architectural gems of Natchez, it exemplifies the frontier elegance that prevailed during the early years of the Mississippi Territory. It was here also that the American Flag was raised in 1797 by Major Andrew Ellicott, acting on orders of President Washington.

Massive columns support such grand old mansions as Rosalie, The Elms, The Briars, Cherokee, Elms Court, Elgin, Fair Oaks, Gloucester, Dunleith, D'Evereaux, Auburn and Longwood. The latter, the largest octagonal house in America, remains unfinished—a star attraction in the lineup of antebellum homes. Workmen's tools lay scattered in rooms upstairs, left as they were when Natchez residents fled during the Civil War. Scaffolding still stands. Wheelbarrows are laced with spider webs. Some insist the ghosts remain as well. A superb example of mid-19th-century Oriental style, Longwood became the first national historic landmark in Natchez. Mostly, though, Greek revival dominates the architectural style among the old mansions, a classic example being Dunleith with its great colonnaded galleries.

Like Spanish moss dripping from some gnarled old oak, history hangs heavy in Natchez. Its homes have sheltered such legendary figures as Henry Clay, Lafayette, Jenny Lind, Samuel

Clemens and Stephen Foster. Andrew Jackson wed his beloved Rachel at Springfield and Jefferson Davis took his bride at The Briars. For the visitor who misses either the Spring or Fall Pilgrimage, 13 of Natchez's great homes remain open year-round, as does King's Tavern—considered to be the oldest house in the Natchez Territory. Operated as a tavern between 1789 and 1820, it was restored in 1970 by the Pilgrimage Garden Club with a Southern-style menu featuring mint juleps, warm cider, sausage, red beans, rice, gumbo and catfish.

Other action takes place along Silver Street beside the muddy old Mississippi, Silver Street being the only remaining avenue in that section of the city called Natchez-under-the-Hill. During cotton days it was lined with bordellos—as well as rough and tumble saloons. Mississippians compared it with San Francisco's Barbary Coast, claiming it was the wickedest piece of real estate in the entire nation. Recently several Natchez citizens got their imaginations in gear and livened up the once-deserted street with a saloon featuring mint juleps and a restaurant that served hush puppies, mustard greens, corn bread and catfish. After getting their fill, guests return to the Mississippi Queen to watch the river, just as Huck Finn did in his make-believe world. ■

A SPECIAL OFFER OF DEPENDABLE FIRE PROTECTION FOR YOUR HOME AND FAMILY

In case of a sudden fire, would you know soon enough to escape in time? Is your family trained in proper procedures to save themselves?

What every family should know about fire safety has been included in a compact pamphlet which is yours **FREE** with each **GUARDIONSMOKE & FIRE DETECTOR** you order. **PLUS**, you will receive window cards to let the firemen know which bedrooms are occupied by children or people who need help!

FREE POSTERS and literature will be sent to lodges or companies for special projects with a reduced rate for bulk shipping and handling.

Offer limited to manufacturers warranties only.

HOW TO ORDER: To order one or many units, or for more information on lodge projects, fill out coupon and mail to . . .



the people protectors INC
105 RIDGE ROAD • MUNCIE, IN 47304

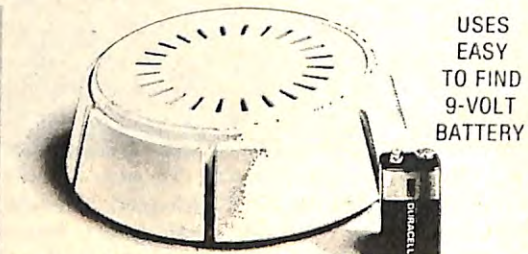

USES EASY TO FIND 9-VOLT BATTERY

You can't buy better than . . .

GUARDION™

SMOKE & FIRE DETECTORS

Rated *BEST* by National Consumer Tests!

- U. L. APPROVED
- EARLIEST WARNING
- 9V BATTERY
- 85 DECIBEL ALARM
- LOW BATTERY WARNING

\$23⁹⁵ each

Plus \$3.00 each for shipping and handling. (Total price \$26.95) Ind. residents add 96c sales tax.

TO: the people protectors, inc.,

105 Ridge Rd., Muncie, IN 47304

- Check enclosed Send information on special projects for Lodge or Companies
- Send C. O. D. (add \$1.25)

NAME _____
 LODGE NO OR CO NAME _____
 ADDRESS _____
 CITY _____ STATE/ZIP _____
 SIGNATURE _____

DON'T DELAY, THEY MAKE EXCELLENT CHRISTMAS GIFTS!

OUR WARRANTY IS FANTASTIC OUR PRICE IS UNBEATABLE

14 1/4"
CARVING KNIFE

12 3/4"
CLEAVER

10 3/4"
COOK'S KNIFE

8" PARING
KNIFE

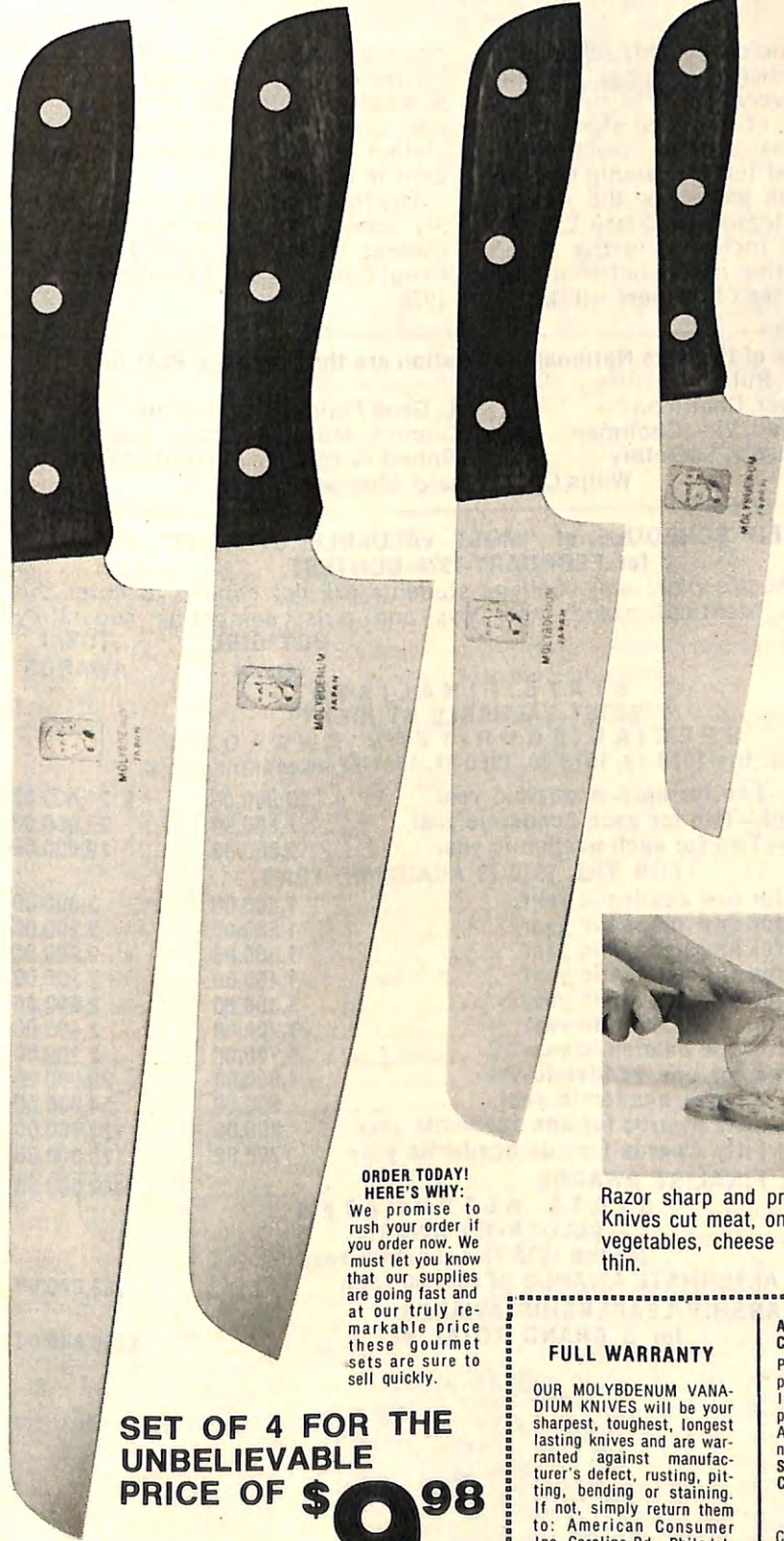

BECAUSE WE IMPORT DIRECT FROM THE FACTORY — AND SELL DIRECT BY MAIL TO YOU!

Simply here are the facts:

1. MOLYBDENUM VANADIUM STEEL, very effective — makes our knives razor sharp. You will cut slices so thin you'll see through them. Carve a roast wafer thin. Cut a soft spongy tomato to perfection. Slice an onion so close that you'll read the small logo on the blade while it's in the onion.
2. MOLYBDENUM VANADIUM STEEL makes our gourmet knives virtually indestructible. Please, please don't sharpen our knives . . . Experts say our edges will **never ever** have to be sharpened the old way. Simply rub them over any china plate and the razor honed blades will be restored. It is reported that no other knife in the world whose edge is so perfect can be restored so easily. Metallurgists say they won't bend, dull, rust, or lose their hardness ever.
3. MOLYBDENUM VANADIUM STEEL makes these knives durable and tough. Cut through big bones easily and effortlessly. No job too tough. Glide through big turkeys. Tough, but flexible, cuts slices close to bone and then cuts bone in half cleanly.
4. BEAUTIFULLY DESIGNED set of 4 with handsome rosewood handles. Magnificent in attractive design and practical in every way. 14 1/4" carver, 12 3/4" cleaver, 10 3/4" cook's knife, 8" parer. Stunning rosewood handles are impervious to grease and oil and safety bonded to the blades. You'll be proud to display these knives.
5. *OUR WARRANTY. We have a super fantastic product at a great price and we are willing to warrant these gourmet knives unconditionally. If you don't agree that our knives are the best cutlery offer anywhere, return them for full purchase price anytime. Not ten days, not thirty days, not even ten years! Return them anytime for full refund. Save our unconditional warranty and maybe your great grandchildren can refund your sets. We're not worried because even three or four generations from now these knives will be razor sharp, free of rust, and as beautiful and practical as they are today.

**ORDER TODAY!
HERE'S WHY:**

We promise to rush your order if you order now. We must let you know that our supplies are going fast and at our truly remarkable price these gourmet sets are sure to sell quickly.

SET OF 4 FOR THE UNBELIEVABLE PRICE OF \$9⁹⁸

Canadian customers, please send orders to:
Mail Store Ltd., Dept. VM
312 Rexdale Blvd., Toronto, Ontario M9W1R6
(Ontario and Quebec residents add sales tax)



Razor sharp and precise, the Total Edge Knives cut meat, onions, luncheon meats, vegetables, cheese — anything — paper thin.

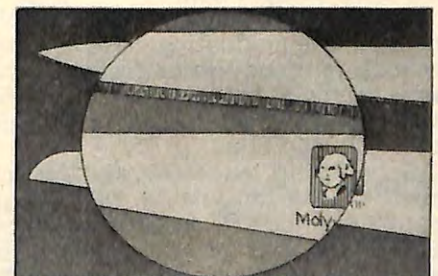

On ordinary knife, edge is just a fraction of total surface. On the Total Edge Knives, the entire blade is the cutting edge.

© 1977 American Consumer Inc., Caroline Rd., Phila. PA 19176

MAIL NO-RISK COUPON TODAY

FULL WARRANTY

OUR MOLYBDENUM VANADIUM KNIVES will be your sharpest, toughest, longest lasting knives and are warranted against manufacturer's defect, rusting, pitting, bending or staining. If not, simply return them to: American Consumer Inc. Caroline Rd., Philadelphia, PA 19176, for a full refund (except postage & handling) or replacement at your option.

AMERICAN CONSUMER, Dept. VM-379
Caroline Road, Philadelphia, PA 19176

Please rush me _____ (VM) Set(s) of 4 Molybdenum Steel Knives at only \$9.98 plus \$1 postage & handling.
If I am not completely satisfied, I may return them for a full refund of purchase price (except postage & handling).
Amount enclosed \$_____ PA residents add 6% sales tax. Check or money order, no CODs please.
SAVE \$1.00 — Order 2 Sets for only \$18.96. Add \$1 postage & handling.

CHARGE IT: (check one) Exp. Date _____
 BankAmericard/Visa Master Charge
 American Express BANK NUMBER _____

Credit Card # _____
Name _____
Address _____ Apt. # _____
City _____ State _____ Zip _____
8090-086

SCHOLARSHIPS for STUDENTS



ELKS NATIONAL FOUNDATION

TRUSTEES OFFER \$808,800 IN 1978 AWARDS

FOR THE ACADEMIC YEAR 1978-1979 the Elks National Foundation Trustees are offering 1,100 college scholarships ranging from \$600 to \$3,000 and totaling \$808,800.00.

During the many years in which this annual scholarship assistance competition has been in existence, the Elks National Foundation has helped thousands of worthy American students of good character and behavior patterns, and with superior scholastic attainments and leadership qualities, to begin their college education under favorable circumstances.

The 1978 Schedule of Awards includes 500 "Most Valuable Student" Scholarships awarded in nationwide competition, and 600 scholarships each for \$600 allocated on a state-quota basis. Six special four-year scholarships are to be awarded to the three highest rated boys and girls in the 1978 competition.

Applications may be made by students in the graduating class of a high school, or its equivalent, who are citizens of the United States of America and residents within the jurisdiction of the B.P.O. Elks.

Scholarship, leadership and financial need are the criteria by which applicants are judged. Experience shows that students who qualify for final consideration usually have a scholarship rating of 90% or better and stand in the upper 5% of their classes.

All scholarships are in the form of certificates of award conditioned upon the enrollment of the winners in an undergraduate course in an accredited college or university.

Application must be made on an official form furnished by the Elks National Foundation and entitled "Memorandum of Required Facts," which will be available at Elks lodges after December 1, 1977. Applications, properly executed, must be filed not later than February 10, 1978 with the Exalted Ruler or Secretary of the Elks lodge in whose jurisdiction the applicant resides.

Lodge officers are requested to noti-

fy school principals of this scholarship offer, to publish it in lodge bulletins and make every effort to bring it to the attention of qualified students.

Applications will be reviewed by lodge and district scholarship committees and then judged by the scholarship committee of the State Elks Association for inclusion in the state's quota of entries in the national competition. Names of winners will be an-

nounced about May 1, 1978.

Requests for additional information should be addressed to the Scholarship Chairman of the State Elks Association of the state in which the applicant is resident.

The National Association of Secondary School Principals has placed this contest on the Advisory List of National Contests and Activities for 1977-1978.

Trustees of the Elks National Foundation are the following Past Grand Exalted Rulers:

John L. Walker, Chairman
William A. Wall, Vice-Chairman
Horace R. Wisely, Secretary

E. Gene Fournace, Treasurer
Glenn L. Miller, Assistant Treasurer
Robert A. Yothers, Assistant Secretary

Willis C. McDonald, Member

SUGGESTED SCHEDULE of "MOST VALUABLE STUDENT" AWARDS for FEBRUARY-1978 CONTEST

For high school seniors only. College students are not eligible to enter this competition. Identical awards for boys and girls, competing separately.

	BOY/GIRL (each)	TOTAL AWARDS
STATE FINALISTS		
"MOST VALUABLE STUDENT"		
SPECIAL FOUR-YEAR AWARDS		
for the 1978-79, 1979-80, 1980-81, 1981-82 academic years		
First Award—Two for each academic year.....	\$3,000.00	\$ 24,000.00
Second Award—Two for each academic year.....	2,500.00	20,000.00
Third Award—Two for each academic year.....	2,000.00	16,000.00
FOR THE 1978-79 ACADEMIC YEAR		
Two Awards for one academic year.....	1,800.00	3,600.00
Two Awards for one academic year.....	1,600.00	3,200.00
Two Awards for one academic year.....	1,500.00	3,000.00
Two Awards for one academic year.....	1,400.00	2,800.00
Two Awards for one academic year.....	1,300.00	2,600.00
Two Awards for one academic year.....	1,200.00	2,400.00
Two Awards for one academic year.....	1,100.00	2,200.00
Twenty Awards for one academic year.....	1,000.00	20,000.00
Sixty Awards for one academic year.....	900.00	54,000.00
One Hundred Fifty Awards for one academic year.....	800.00	120,000.00
Two Hundred Fifty Awards for one academic year.....	700.00	175,000.00
500 STATE FINALIST AWARDS		448,800.00
STATE ALTERNATES		
ALLOCATED AWARDS		
for the 1978-79 Academic Year		
600 STATE ALTERNATE AWARDS at \$600.00 each		360,000.00
1,100 SCHOLARSHIP/LEADERSHIP AWARDS		
for a GRAND TOTAL of		\$808,800.00



NEWS OF THE LODGES



National Home garden produce

The eighth annual Motorcycle Poker Run, which featured a 120-mile course, began and ended at **Long Beach, CA, Lodge**. There were 384 people who signed in for the ride and approximately 150 more who rode as passengers. The Motorcycle Committee raised \$1,000 for charitable work during the year. **Concord, CA, Elks** totaled their contributions to charity so far this year at \$12,000. The funds were made available through Concord Charities, Inc., which is the lodge's bingo game. The beneficiaries of the money include the National Foundation, cerebral palsy projects, Meals on Wheels, the Concord We Care Day Center, and the Salvation Army.

Members of **New Haven, CT, Lodge** were pleased to hear that Meyer Abramowitz's generosity will benefit the lodge's Crippled Children's Fund and the lodge. Brother Abramowitz disclosed that he has included donations to the Fund and the lodge in his will.

A scholarship for \$1,000 annually for four years was awarded to Dawnne Casey by the **New Jersey State Elks Association**. Miss Casey, who is paralyzed from the waist down, plans to specialize in speech therapy while at college. As guests of **Cherry Hill Lodge**, the Casey family were entertained at the annual state association banquet, where Dawnne received the scholarship for crippled high school girls.

Profits from the snack bar at the swimming pool and recreation park at **Tucson, AZ, Lodge** help support the

major project, the Long Term Care Unit for all Elks. The major project auxiliary, including Brother Joe and Laurie Cox and Brother Bob and Eileen Sarjeant, volunteered to man the refreshment stand.

Watermelons, cabbages, peppers, and cantaloupes were among the fruits and vegetables harvested from a two-acre plot this year by a group of Brothers at the **National Home** in Bedford, VA. Unloading produce for the Home's kitchen were gardeners (from left) Bill MacKay of Tewksbury-Wilmington, MA; George McCrary of Jacksonville Beach, FL; Ned Groom of Circleville, OH; Ray Walterscheid of Evanston, IL; James McCormack of Houston, TX; Jim Norris of Muncie, IN; Sid Clark of Lynchburg, VA; and Felix Francois of Fort Lauderdale, FL.

It took **B. G. Morse** of **North Fort Lauderdale, FL, Lodge** 24 days to bicycle from San Diego, CA, to Fort Lauderdale on behalf of the **Harry-Anna Hospital**. The 2,565-mile trek brought in over \$1,000 from pledges by state Elks.

A first at **Idaho Springs, CO, Lodge** was the recent initiation of three brothers. David, Robert, and Daniel Eppinga, who joined the order together, received a welcome from ER Larry Romine and their new Brothers.

The Past Exalted Rulers of **Red Hook-Rhinebeck, NY, Lodge** paid tribute to the Lodge's first Exalted Ruler, the late Louis Downing, by holding funeral services for him in Red Hook. PER John Scattergood conducted the ceremony.

Local Elks, Little League administrator Yorke Nelson, and the mayor, Mr. Jones, gathered at the Little League Park in **Cedar City, UT**, for a brief ceremony dedicating the park to the city. It had been discovered by the lodge, which maintains the park on a yearly basis, that in over 20 years of use, it had never been officially presented to the city.

A large buffet dinner was held by **Redondo Beach Lodge** for Boy Scout Troop No. 849 of Manhattan Beach, CA, their Scout Leaders, and their sponsors in honor of new Eagle Scout Robert Northington. ER Don Smith presented a certificate to the young man.

Although multiple sclerosis has now confined Brother Bernie Eirenberg to a wheelchair and he has discontinued his activities on the several lodge committees on which he served, he still attends lodge meetings and social activities with a little help from his fellow members at **Sioux Falls, SD, Lodge**. The Brothers carry him up and down the stairs, shuffle and deal cards for him, and generally assist him with things he cannot do alone. Brother Eirenberg, who has written a book on exercises for the handicapped, commends the Elks for their consideration and for accepting him as "just one of the guys."

B. G. Morse overhauls his bicycle.





THE PINE TREE CAMP for Crippled Children and Adults was the focus of Waterville, ME, Lodge's charity recently when lodge members purchased a van for the camp. Delivering the vehicle to the camp director (right) were (from left) ER Robert Quirion, Paul Jacques, and Danny Doyon.



OBSERVING as Longview, WA, ER Tony Pothier presented a trophy to Kevin Osborn for catching the most spiny-rayed fish in the annual Elks Kids' Fish Frolic was Esq. Dave Burch. The event was co-sponsored by the lodge and the Longview *Daily News*, with the cooperation of the Cowlitz Jeep Club, the Police Reserve, and the State Game Commission.



BRIAN DOYLE and Dennis Irwin, members of the Syracuse Chiefs Baseball Club of the International League (New York Yankee Farm Club), had an attentive audience during a baseball clinic sponsored by Cortland, NY, Lodge for boys and girls between the ages of 8 and 15. More than 150 youngsters attended the clinic, which was held at State University College.



"WHISPERING JIM" OSBORNE (center), the oldest living Past Exalted Ruler of Glendive, MT, Lodge, recently accepted a plaque acknowledging his 50 years of continuous service as a lodge trustee. PER Paul Winhofer (left) and ER Karl Overlie presented the award to 89-year-old Brother Osborne, who is known for his hobby of making gavels for auction to benefit the major project and for presentation to the Grand Exalted Ruler.



THE VISITATION TEAM of Colonie, NY, Lodge, including Est. Lead. Kt. Michael Hoblock Jr. (left), Vets Chm. Edward Klimek (second from left), and ER Roland Babbitt (right), offered special congratulations to Spanish-American War veteran Edward Ocker on his 101st birthday. Lodge members travel to the VA Hospital in Albany weekly to spend some time with Mr. Ocker and the other patients.



DURING HIS VISIT to Frederick, MD, Lodge, then-GER George Klein (left) personally presented an Eagle Scout award to Glen Gardner. The young man is a member of Frederick Troop No. 1998.



ON BEHALF of the Oregon State Elks' Children's Eye Clinic, Dr. Kenneth Swan (left) and patient Rodrigo Melo (center) accepted a check for more than \$17,000. Presenting the money for the clinic's operating expenses for the first half of the year were (from left) Committeeman Ernie Nutter of Gateway Lodge, VP Bruce Reed, and Committeeman Clyde Larson of Beaverton Lodge.



◀ **WHEN** the Elks of Princeton, NJ, Lodge learned that the Rock Brooke School for handicapped children with learning disabilities needed new and modern equipment, they came to the rescue with a donation of \$500. After presenting the check to Mrs. Crystal Sargent, school director, Crippled Children's Chm. George Balerno and ER Douglas Watson spent the afternoon playing with two of the children.



CHECKING a stop watch in preparation for the Woodland, CA, Invitational Junior-Senior Swim Meet at the community swim center were (from left) local ER Bob Alspaugh, Ned Driggers, director of the meet, Clancy Duppong, and Bea Blosky. The Elks' contribution of \$350 was used to contract for Mega electronic timing for the competition.



A BURN FUND formed by the fire departments in Cortland County to assist fire victims with some of their medical expenses received an assist from the Homer, NY, Elks. A check for \$100, representing the proceeds from a lodge dance, was turned over to County Burn Fund Chm. Dave Reynolds (left) by Gary Harrington (center) of the Elks House Committee and ER John Reagan.



ADMIRING an Ohio-shaped plaque sent to Findlay, OH, Lodge were ER Robert Elsbury (left) and Secy. Paul Schlencher. The token of appreciation was sent by a Michigan traveler who was one of 80 motorists stranded at the lodge during a snowstorm last winter. The lodge provided not only shelter for the night, but also free food and drink for their unexpected guests.

THE VISION CLINIC of the Cotting School for Handicapped Children, which offers eye care services, without charge, to the school's students and handicapped people in the community at large, was the beneficiary of a \$1,000 donation made by the Massachusetts Elks Association. William Carmichael (second from right), superintendent of the school, thanked (from left) SP Albert Murphy, Trustees Chm. Peter Stupak, and State Treas. Donald Podgurski for the Elks' support.



A CHECK for \$12,000 given to District Major Project Chm. Daniel Capella (second from right) brought to over \$28,000 the amount contributed by Liverpool, NY, Lodge to cerebral palsy over the past three years. Representing the lodge at the presentation were (from left) PER Larry Liptak and Co-chairmen Bill Ball and Thomas Fields.



A SWIM MARATHON sponsored by Clayton, MO, Lodge raised an estimated \$1,200 to help children like Steve Roloff (left) and David King (seated), who attend United Cerebral Palsy Association treatment centers in the St. Louis area. Greg Ebe (second from right), who swam 13 miles or 455 laps, accepted his trophy from ER Charles DePaepe, while Candy Carossella, who completed 10 miles or 350 laps, received her award from Est. Lead. Kt. Anthony Bonano, the lodge's social and community welfare chairman.



THE PURCHASE of a new wheelchair for the Handicapped Children's Center was made possible with a gift of \$290 from Muskegon, MI, Lodge. Mrs. Mary Huth of the Center accepted the check from ER Jerry Wiersma as Joe Nickless (left) and Chm. Mike Sarade (right) observed. Brother Sarade and his committee have raised over \$50,000 for the handicapped children's fund.

(Continued on page 39)

MARATHON



One segment of runners leaves the starting line at Fort Thomas, KY. Five separate starting segments were staged, due to the large number of contestants in the 1976 Cincinnati Elks-AAU Thanksgiving Day Marathon. The race ends at the Cincinnati Lodge No. 5, 1900 Central Parkway.

Few sports events can claim as ancient and distinguished a lineage as the one Cincinnati Lodge No. 5 has engrossed itself in every Thanksgiving morning for the past 68 consecutive years.

The Cincinnati Elks start their AAU-sanctioned marathon—the second-oldest in the nation—5.5 miles away in Fort Thomas, Kentucky. Over the years the starting site has changed, but now it remains at Fort Thomas.

From there nearly 500 men, women, girl and boy walkers and runners pursue a course through Southgate and Newport before bridging the Ohio River and crossing the finish line at the Cincinnati Lodge, 1900 Central Parkway.

Cincinnati's marathon course has its parallels in the Greek plain, Marathon, which gave its name to the ancient sport in 490 B.C. The Marathon plain is five miles long—almost the exact distance of the Elks race—and two miles wide. Through the plain courses a minuscule copy of the Ohio River, the Charadra Brook.

Marathon is 24 miles from Athens, the distance giving its statistic to the current standard of 26 miles, 385 yards. However, today any long-distance race is referred to as a marathon. The purist Olympic Games and Boston's venerable event hold strictly to the distance and the name as "by the book" marathons. Even Olympic champion Paavo Nurmi's victories in the 5- and 10-mile runs were not classified as marathons.

This doesn't daunt the Cincinnati Lodge in either enthusiasm or involvement. Not only does their activity perpetuate the history of the first recorded Olympic race in 776 B.C., but it also is, by its actual staging, an unheralded salute to the remarkable feats of Olympic champion runner, the Athenian, Pheidippides.

Greek General Miltiades knew that Eretria had fallen and that war with King Darius' Persian warriors was imminent, so he sent Pheidippides to seek aid from the Spartans. For two days and two nights the Greek courier ran, swam rivers and climbed mountains to reach the Spartans on the Isthmus of Corinth. He retraced his course and brought back word that the Spartans would leave at the next moon. Religious observances delayed their departure and they did not arrive to bolster the Greeks and Plataeans until the Battle of Marathon was over.

Miltiades feared that Athens would be attacked by a fleet dispatched by the Persians off the beachhead near Soros. He called upon Pheidippides to run from Marathon's battlefield to Athens and tell the city that the Persians had been defeated. This would give Athens a big morale boost and time to cinch their belts to battle the enemy with new vigor.

Although he had taxed himself on the long trip to the Spartans and back, and had fought in the Marathon battle, Pheidippides threw down his long spear and heavy shield and took off for Athens. At the outskirts of the city he dropped dead, but not

before he had gasped, "Rejoice . . . we conquer." This deed gave birth to the marathon.

Exceeded in age and length only by the annual Boston Marathon—the Cincinnati run is only seven years younger—the Elks-AAU blister maker has its own unashamed distinctions. Like its Bean-town peer, the Cincinnati event started with walkers only. Tradition still holds to this original concept and the 1976 Turkey Day special had a field of nine walkers.

Sponsors proudly point out that last year's overall winner, Richard Green of Essex, England, came 200 miles from Eastern West Virginia University to run in their marathon. He is in this country on a two-year student visa, had not competed in the United States prior to the 1976 Elks run, and expects to be at the starting line for the 1977 challenge.

Two-time winner Samuel Schermdeck of Newport, Kentucky, won his laurels in 1913 and 1914. Although now 86, champion Schermdeck is on hand to watch and cheer each year.

Cincinnati divides its field of nearly 400 into 10 age groups. Girls can run in the 10 o'clock opener if they are 13 or younger, or in the one for 13-year-olds and older. Male contestants have a choice of eight age groups: 13 and younger, 14 to 16, 17 to 19, 20 to 24, 25 to 27, 27 to 30, 31 to 39, 50 and older. Walker contestants are not restricted by age.

Youth is well-served by the Cincinnatians, but age has its day, too. Winning senior runners in 1976 were Roland Anspauch, 56, first place; Elmer Gaston, 55, second; Bob Thompson, 56, third, and Hank Braddock, 57, fourth.

Running is probably the oldest form of athletic competition. The ancients had to run, and run fast, to escape wild and hungry beasts. Marathon racing today is called the most strenuous of any track or cross-country running, because it is all road work.

Despite the tough physical pounding taken by the runners, the Elks had 441 finish the course in 1976, or 97.7 percent of the field. Elks do assuage the exhausted contestants, members of their families and friends by helping to revive them at the Lodge home with refreshments, along with dispensing gallons of coffee and hot soup.

AAU sanctions and supervises the race and furnishes five judges. City police of Fort Thomas, Southgate, Newport and Cincinnati cooperate in traffic control along the route. Cincinnati Elks take over many of the chores at the Ohio River bridge and most of the street crossings in Cincinnati.

Lodge No. 5 awards 40 trophies and 68 medals to the marathoners. Their field of competitors is drawn from high schools, grade schools, colleges and track clubs in Kentucky, West Virginia and Ohio.

Whatever is assembled for the 10 a.m. start of the 68th marathon on November 30, Elkdom can be assured that the race won't be a turkey. ■

FREE This 353 Page "Estate Planning Guide"

It will help you plan
your family's future.



It's yours, without obligation,
from Rock of Ages—makers of
the world's finest memorials.

It's never too soon to start thinking about the future and how you will provide for your loved ones. That's why your local authorized Sealmark Rock of Ages dealer would like you to have this book, now, with his compliments. You'll find hundreds of valuable ideas for protecting your estate and building maximum financial gains for you and your heirs. And you'll find a special section that provides important pointers on how to choose a family memorial—including details about exclusive Rock of Ages "Sealmark" Memorials. The Sealmark, permanently etched on every genuine Rock of Ages Memorial, is your assurance of unsurpassed quality and lasting value.

And the only memorial backed by a full, written warrantee — without time limit—against any defects in materials or workmanship.

Mail coupon today with 50¢ to cover postage and handling. Offer expires Dec. 31, 1977. Limit one per family or address.

TO: ROCK OF AGES ESTATE GUIDE, E
P.O. Box 4342, Chicago, Ill. 60680

In Canada: Fairmont Granite, Ltd.
P.O. Box 230, Beebe, Que. JOB 1EO

Gentlemen:
Please send me your free "Estate Planning Guide," without obligation. Enclosed is 50¢ for postage and handling.

Name _____

Address _____

City _____ State _____ Zip _____

Please allow 2-4 weeks for delivery.

Louder and Funnier

(Continued from page 18)

Like Lincoln, Franklin D. Roosevelt laid his humor on heavily and with a broad brush. He loved puns, and most of them were horrendous. To a staffer inundated with dimes during a White House-sponsored March of Dimes campaign against polio, FDR wrote: "I hope you are having a good dime." Practical jokes—albeit of the harmless variety—tickled his funny bone. He "rejected" an invitation to one of his own inaugurations and gave his peripatetic wife the wartime code name of "Rover." Once Mrs. Roosevelt left the White House early, before the President arose, to visit a nearby penitentiary. FDR got up a short time later and called Eleanor's secretary, Malvina Thompson, to ask where his wife was.

"She's in prison, Mr. President," came the reply.

"I'm not surprised," said FDR. "But what for?"

Indeed, Roosevelt's sense of humor was a blessing both to himself and to the nation he led through a depression and a global war. No other period of our history has been more violent and ridden with crisis. The American people desperately needed a little comic relief. Thanks both to the jokes that FDR told and the jokes told about him, they could laugh either with him or at him, according to which side of the Roosevelt fence they were on.

From the end of the Era of Roosevelt through the rest of the 1940s and all of the 1950s, not much humor could be heard coming from the White House. Oh, there was Truman gleefully brandishing the famous 1948 edition of the *Chicago Tribune* ("DEWEY DEFEATS TRUMAN"), calling the White House "the finest prison in the world" and explaining his "give 'em hell" speeches: "I never give them hell. I just tell the truth and they think it's hell." But it was, overall, a pretty sober-sided period in American politics.

Then came the Era of Kennedy, and laughter returned to Washington. JFK's brand of humor wasn't broad and robust like Roosevelt's, nor did it have the rapier-like quality of the Churchillian wit. Rather it was a sly, roguish sort of humor, thoroughly spontaneous and as much a part of his being as his electric energy. "Kennedy likes to laugh and likes to make people laugh," said his journalistic friend, Ben Bradlee of the *Washington Post*. Arthur M. Schlesinger, Jr., the Harvard historian who became his special assistant, called Kennedy "playful."

There was the time when Kennedy spoke at a \$100-a-plate affair given in his honor and confessed, "I could say
(Continued on page 67)

SPARE TIME INCOME? SELL KNAPP SHOES!

Sell famous Knapp Cushion Comfort Shoes full time or part time to supplement your income. Enjoy the financial success and security you've always dreamed about. Millions of repeat customers. Earn higher commissions plus bonuses. No investment. Free selling and training kit to get you started. America's No. 1 company in the direct selling shoe industry. Write I. Margolis, 610 Knapp Centre, Brockton, Mass. 02401.



The more for the money shoe.

INCREASE YOUR FUND-RAISING PROFITS!

CINEMA RACES means fund raising without fuss—but more fun! No merchandise to stock or sell. You keep the funds you raise (except for the nominal cost of your CINEMA RACE package). We provide sound and color horserace films, pro-

grams, tickets, play money, combination tickets plus the easy instructions for running a day at the track in your hall. Used by hundreds of organizations in successful fund-raising events.

Write or call for details.

CINEMA RACES

Dept. E21
A General Instrument Company
383 Hillen Rd. / Towson, Md. 21204
301-321-8166



WIN WYOMING OIL \$MILLIONS

Others do every month in U.S. Government Oil Lease Drawings. If you are 21 you can participate equally with major oil companies in this legal lottery. A \$20 tax deductible filing fee can return \$75,000 or more immediately plus a possible million in future income. Write for free information.

Milligan Trust, Lock Box 3578-E, Boulder, Co. 80303

REMBRANDT DID IT IN OILS...

Let us do it in
BRONZE PLAQUES
FOR ALL OCCASIONS
Write for Free Catalog E23
Engraved Plaques E21



INTERNATIONAL BRONZE TABLET CO., INC.
150 W. 22nd St., N.Y., N.Y. 10011 212-WA 4-2323



ELKS RITUAL CLOCKS
No initiation or lodge ceremony is truly complete without our Emblem Model (as shown) or a Custom Ritual Clock. A Portable Model suitable for funeral services is also available. Optional features may be selected. Over 40 years of satisfied customers.
11th HOUR MFG. CO.
1137 Dearborn St.
Aurora, Ill. 60505
312-851-7353

HYDRAULIC JACK REPAIRS

Earn While You Learn In Your Spare Time

Trained and qualified mechanics needed NOW to service inoperative hydraulic jacks. BIG opportunity for ambitious men. We show you HOW—in your basement or garage to earn spare time cash in an expanding industry. Don't wait, ACT NOW! Get the facts.

Write for folder E-11 and free bonus offer

Hydraulic Jack Repair Manual Co., Inc.
G. P. O. BOX 3 • STATEN ISLAND, N. Y. 10314

LODGE VISITS



GRAND EXALTED RULER HOMER HUHN, JR.



After spending a day fishing on Jackson Lake, (from left) immediate PSP Ed Young, GER Homer Huhn, Jr., PGER George Klein, State Tiler Neal Petty, SP Gene Dunn, and VP Bill Kupper attended a fish fry hosted by Jackson, WY, Lodge. Brothers Huhn and Klein and their wives were on a Wyoming visit which included tours of Yellowstone and Grand Teton National Parks.



A greeting from the state of North Dakota was extended to GER Homer Huhn, Jr. (center) by Governor Arthur Link (second from right) from the capitol building in Bismarck. Local Elks who joined the GER included (from left) SP David Price of Dickinson Lodge, PGER Raymond Dobson of Minot, and Grand Tiler Martin Gronvold of Mandan.

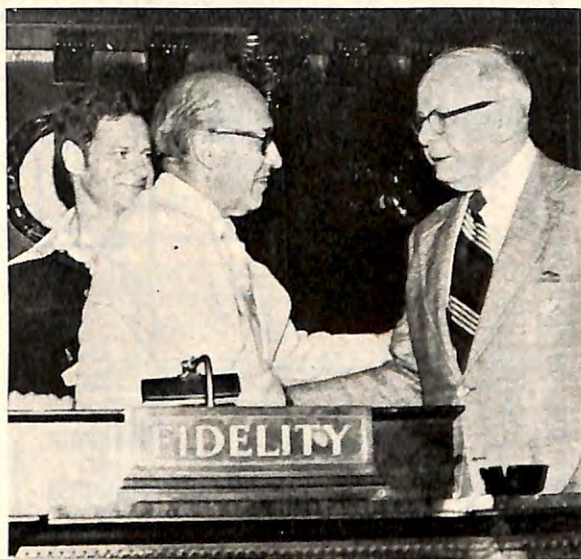

GER Homer Huhn, Jr. (center) was the guest of honor at the annual convention of the West Virginia Elks Association held in Wheeling. On behalf of those in attendance, PGER Wade Kepner (right), the state sponsor, and outgoing SP Paul Duffy extended an official welcome to Brother Huhn.

GER Huhn Speaks at Mandan

The Elks of Mandan Lodge in North Dakota welcomed Homer Huhn, Jr. recently—marking the first official Grand Exalted Ruler visit they have received since 1956. Interviewed by the local media during his stay, GER Huhn related that being a member of the Elks is not just an opportunity for social activities and fun; it also involves responsibilities and awareness of the principles to which the organization is dedicated.

As an example of Elkdom at work, he cited the youth programs, especially the Scout troops sponsored by 1,400 lodges and the National Foundation funds made available for student scholarships and handicapped persons. "In the past, the Elks have kind of hidden their talents," the GER explained. "We've got to let people know what the Elks are doing." Brother Huhn urged his fellow members to publicize the services and work of their lodges and to provide local news people with information about the activities sponsored by the order. He also informed his audience that a program for training Brothers how to disperse information to the news media had been initiated.

Brother Huhn's remarks were made at a dinner which was attended by Elks from all 11 of the lodges in the state. Entertainment for the event was provided by the Bismarck Elks Chorus.



Maumee, OH, Lodge welcomed GER Homer Huhn, Jr. (center) and Mrs. Huhn, along with the state officers and their wives, recently. ER William Zeisler (right) took Brother Huhn and SP Robert Kennedy on an inspection tour of the \$300,000 addition to the lodge which is now under construction.

NEWS OF THE STATE ASSOCIATIONS



A \$1,000 contribution to the National Foundation by then-DDGER George Albrink (center) in the name of then-GER George Klein (second from right) earned an honorary founder's certificate which was given to Brother Klein during the Kentucky Elks' yearly convention. Observing the presentation were (from left) outgoing SP Ted Zimmer, PSP Jerry Staubach, and PGER Edward McCabe, the state sponsor.



During a pause between meetings at the Washington State Elks convention (from right) SDGER John Raftis, PGER Robert Yothers, and then-GER George Klein (left) spoke with PER Robley Johnson about the honor he received at the convention. Immediate PSP Walt Swinhoe presented the "outstanding service as an ER" award to Richland Lodge's Brother Johnson.

APPROXIMATELY \$80,000 in cash and pledges was collected for the state major projects during the Exalted Rulers' March, which took place in the Sitka Convention Center. The Alaska Elks met May 12-14, with 188 people in attendance. Participants and visitors included PGER Robert Yothers, Alaska's sponsor, then-SP Walter Swinhoe of Washington, SDGER J. Paul Meyer, and PER Bernie Chillquist of Auburn, WA, Lodge and their wives.

For the third consecutive year, the team from Anchorage Lodge came away with state ritualistic honors. Elected state officers for the year were SP Albert Maffei, Anchorage; Vice Presidents Ralph Magnusson, Sitka; Charles Ingersoll, Anchorage, and Secy.-Treas. Edward Callihan, also of Anchorage.

The Alaska Elks' 30th annual convention is scheduled for May 18-20, 1978, with Fairbanks Lodge as the host. A mid-winter conference was planned for January 20-21 at Wrangell.

THE REPORT of Jim Oliver, administrator of the Harry-Anna Crippled Children's Hospital, was heard by the 1,300 delegates, visitors, and ladies at the May 20-21 gathering of the Florida Elks in Miami Beach. According to Mr. Oliver, 183 children were treated during the year, at an average cost of \$4,950 per patient. Several outpatient clinics supported by the state associa-

tion offered treatment and services to more than 2,000 youngsters. The total expenditures for the complete crippled children's program came to \$869,742 for 1976-1977. The growth of the Harry-Anna Trust Fund through individual voluntary donations and contributions of members and the general public totaled \$476,100. It was also reported that the newly completed Harry-Anna Hospital in Umatilla has begun administering to patients.

Outgoing SP Charles Pride, who was the convention's presiding officer, welcomed guests of honor PGER William and Lois Wall. At the memorial service, PSP Al Ehrlich, a member of the GL New Lodge Committee, and PDD Dan Satin addressed those assembled. The team from Tallahassee Lodge won the state ritualistic contest.

Chosen State President during the proceedings was Pensacola Brother Robert Fluck. Also elected were Vice President-at-Large Ed Royal, Vice Presidents Aubrey Callahan, Cecil Blue, William Howard, Nick Foreso, Hubert Horwitz, William Trowe, Kenneth McStravic, Edgar Armstrong, Oris Townsend, Richard Bernard, Secy. Ben Brown, and Treas. Frank Holt.

The convention closed with the President's Banquet and Ball. A mid-year meeting was scheduled for October at Eustis and Umatilla, and Daytona Beach was named as the site of the

72nd annual conclave of the state Elks to take place in May.

HOSTING this year's annual meeting of the Kentucky Elks Association was Louisville Lodge. The May 26-28 proceedings attracted 290 people, including then-GER George and Ruth Klein and PGER Edward and Maggie McCabe. Mrs. Klein and Mrs. McCabe were the honored guests at a luncheon sponsored by the newly formed Kentucky State Elks' Auxiliary. A formal dinner-dance featured Brother Klein as principal speaker.

Some \$4,500 was allocated by the state Elks for the major project, cerebral palsy, while \$3,000 was set aside to finance the state "Hoop Shoot" contest. Scholarships totaling \$2,000 were announced. Louisville Lodge was declared the winner in the ritualistic competition.

Carrying out the state association's program are the 1977-1978 officers. They include SP William Stamps, Bowling Green; Vice Presidents Charles Stander, Covington; Eugene Butters, Princeton; Joe Pat Gaines, Frankfort, and Secy.-Treas. Garland Guilfoyle, Newport.

A semiannual meeting of the association was planned for November 5-6 at Hopkinsville. Next year's convention will again be held in Louisville on May 26-28.

THE WEEKEND of May 27-29, 140 Elks and their guests gathered in Camp-ton, NH, for the state convention. Representing the Grand Lodge was National Director of the "Hoop Shoot" Contest Gerald Powell, who was accompanied by his wife.

A member of Nashua Lodge, Norman Wrenn, was elected to the state association's highest office. The Vice Presidents who will serve with him are Joseph Landry, Laconia; Douglas Roberge, Littleton; Joseph Mauro, Concord; Herbert Cornell, Lebanon, and Hazen Hayward, Portsmouth. Also holding office this year are Treas. Gerard Gravel of Rochester and Secy. Gaston Dewyngaert of Nashua Lodge. Among the business matters voted on at the convention was the per capita dues increase from 85 cents to \$1.00.

During the proceedings, the newly installed State President announced the location of the first regional meeting, which was held in September at Copper Cannon Lodge, the state major project's summer camp for underprivileged children. The upcoming quarterly meetings will be sponsored by Dover Lodge on November 20, Concord Lodge on January 15, and Nashua Lodge on March 19. The 1978 state convention will be held sometime in May.

INDIANA University School of Medicine and Purdue University representatives delivered reports to approximately 1,100 Elks and their guests regarding the cancer research being conducted with funds from Indiana Elks Charities, Inc., the state major project. Dignitaries on hand for this year's presentation of \$50,000 and \$35,000 to the universities included then-GER George Klein, PGER Edward McCabe, PGER Glenn

Miller, then-Grand Est. Lead. Kt. James St. Myers, then-Grand Trustee William Collisson, National "Hoop Shoot" Director Gerald Powell, then-Assistant Grand Secy. Stanley Kocur, Ohio PSP Sam Fitzsimmons, and Past GL Committeeman William Brunner.

Elected to office during the June 2-5 convention in French Lick were SP Joe Stevens of Elwood Lodge, Vice Presidents Herbert Brautzsch, Fort Wayne; H. Eugene Milliron, Indianapolis; William Booher, Logansport; Robert Gillan, Linton; Russell Phillips, Jeffersonville; Secy. C. L. Shideler, Terre Haute, and Treas. J. L. Miller, East Chicago.

PGER Edward McCabe of Tennessee addressed the conventioners at the Friday night banquet, while then-GER Klein was the principal speaker at the Saturday night banquet. The ritualistic contest was won by the team from South Bend Lodge.

The state officers' meeting will be held at Indianapolis on November 12. June 1-4 will be the dates for next year's convention, which will meet again in French Lick.

SCHOLARSHIPS totaling \$15,900 were awarded to 25 students during the annual convention of the Rhode Island State Elks Association held June 4-5 in Newport. That sum was \$4,000 more than the amount presented by the Elks last year.

Nearly 500 members and their families witnessed the installation of the new officers. William McAllister Jr. of Warwick Lodge was chosen to head the state's approximately 8,000 Elks. He will be assisted by Vice-Presidents Antonio Cabral, Bristol County; Reggie Sassi, South Kingstown; Secy. Thomas Walker, Warwick, and Treas. William Darby, Pawtucket.

THE MORRIS MASINTER memorial award for outstanding service to the Virginia Elks Boys' Camp, the state major project, was presented to Paul Kelly during the June 10-12 conclave of the state Elks in Waynesboro. Ernest Wulzer presided over the annual meeting of the camp's board of directors and delivered a report to the convention delegates.

Nearly 490 members and guests attended the 68th yearly session. Among the distinguished guests present were then-GER George Klein, PGER John Walker, the state sponsor, Grand Forum Chief Justice Alex Harman, Jr., who is also a justice of the Virginia Supreme Court, and Vice Mayor Harley Tomey of Waynesboro.

The annual dues were raised from 60 cents per member to 75 cents, effective April 1, 1978. The Scholarship Committee, under the guidance of George Ofelt, announced awards totaling almost \$10,000, with \$750 coming from the state association.

Dances, cocktail parties, a golf tournament, and the Grand Ball provided opportunities for the convention-goers to relax. Suffolk Lodge took ritualistic honors with a 95.2481 average.

Leading the Virginia Elks for the coming year are SP Bernard Kofira, Norfolk; Vice Presidents Robert Pannell, Clifton Forge; Donald Netschke, Jr., Alexandria; Walter Edmonds, Portsmouth; Secy. Charles Curtice, Petersburg, and Treas. Cecil Duffee, Norfolk.

The Virginia Elks planned to meet again at Charlottesville on October 21-23. Norfolk was chosen for the June 9-11 annual assembly.

MINOT was the site of the North Dakota Elks' 57th annual convention. Registration for the June 10-12 gathering totaled 1,246, which included 254 delegates from 11 lodges. Current records show 32,531 Elks on the membership rolls throughout the state.

Among the dignitaries in attendance were PGER Raymond Dobson, the state sponsor, Grand Forum Justice Edward and Mrs. Alexander of Great Falls, MT, and Lt. Gov. Wayne Sanstead, a member of Minot Lodge. Brother Alexander was the convention banquet's principal speaker, and Brother Sanstead addressed the assembly during the memorial services.

David Price of Dickinson succeeded Kenneth Mullen as State President. Also on the slate of officers are Vice President John Traynor, Devils Lake; Secy. Jack Brown, Jamestown, and Treas. Everett Palmer, Williston. Top honors in the golf tournament went to Gordon Obie of Grand Forks and Wes Cummings of Roseglen.

An increased budget was approved for Camp Grassick, the summer camp



Representing the Grand Lodge at the annual gathering of the Florida State Elks Association were (seated, from left) Norman O'Brien of the State Associations Committee, PGER William Wall, Alvin Ehrlich, then-chairman of the Lodge Activities Committee, and (standing) C. Newt Jones of the Credentials Committee, Robert Grafton, then-Grand Trustees chairman, and Ralph Clements of the Youth Activities Committee.



Special guest then-GER George Klein obliged autograph seekers during the state convention of the Virginia Elks. Waynesboro Lodge hosted the affair.



Then-GER George Klein (left) congratulated Vern Bybee of Twin Falls, ID, who received an award for outstanding youth activities work as outgoing SP Don Gummersall looked on. The Idaho Elks held their annual convention June 23-25 in Twin Falls.

sponsored by the state Elks for handicapped children and adults. Another project which received the backing of the state association was the "Hoop Shoot" Free Throw Contest, which attracted thousands of participants last year.

The North Dakota Elks will hold their 1978 yearly conclave in Fargo.

IN A REPORT given at the state convention, chairmen of the Massachusetts Scholarship, Bowling, and Tour Committees stated that they had experienced record participation during the past year. The June 10-12 meeting of 1,500 Elks and their guests took place in Bretton Woods, NH, where next year's meeting is also scheduled to be held. Heading the slate of officers for the coming year is State President Albert Murphy of Milton Lodge.

THE SATURDAY session of the 76th convention of the Washington State Elks Association contained discussions on the year's fund-raising ventures. The more than 1,300 delegates and their wives in Pasco, WA, listened to reports which totaled lodge contributions to the state major project at \$13,500 and to the National Foundation at \$7,700.

Grand Lodge guests at the June 16-19 meeting included then-GER George Klein, Washington's sponsor PGER Robert Yothers, and Grand Trustee Frank Garland. SP Walt Swinhoe was succeeded in office by Ivan Harlan of Colville. The position of President-Elect is held by C. J. Hauge of Auburn, and the Vice Presidents are William Hood, Lower Yakima Valley; Bill Smith, Mount Vernon; Homer Oberst, Lake-wood; George Frye, Port Townsend; Dick Mitchell, Seattle; Jim Roberson, Mount Adams (White Salmon), and Alex Alexander, Spokane Valley.

The mid-winter meeting will be hosted by Vancouver Lodge in January.

A SCORE of 93.518 in ritualistic competition gave the team from Rock Hill Lodge the state championship during the June 17-19 meeting of the South Carolina Elks Association. Also taking part in the contest were teams from Charleston, Anderson, Florence, Greenville, and Sumter.

Social activities for the 422 people present in Sumter consisted of two dances, a ladies' luncheon, golf, a dinner, and the President's Ball. PGER Robert Pruitt, the state sponsor, was one of the honored guests at the proceedings.

It was reported that the South Carolina Elks made it possible for 60 children to attend summer camp for one week. Three veterans hospitals, the "Hoop Shoot" program, the student legislature, and the scholarship program also received statewide support.

Charleston is the home lodge of newly elected SP A. Herman Schwacke Jr. His fellow officers are Vice President Larry Arazie, Florence, and Secy.-Treas. David Craigie, Charleston.

At the business sessions, delegates decided to hold down state dues and use the interest from bonds in the annual budget. Anderson was chosen as the location of the semiannual meeting, which is planned for January 18-20.

THE WALLACE ELKS Drum and Bugle Corps provided a musical escort for the newly elected state officers, who included two of their fellow lodge members, during the Twin Falls convention of the Idaho Elks. Wallace Brothers James Lynn, Jr. and Ronald Garitone were chosen State President and Secretary-Treasurer, respectively. Also installed were Vice President-at-Large

Sherman Akers of Pocatello and Vice Presidents Donald Bowman, Nampa; John Nanninga, Jr., Lewiston, and Earl Summers, Idaho Falls.

Numbered among the 340 people in attendance at the June 23-25 sessions were then-GER George and Ruth Klein, PGER Frank and Betty Hise, PSDGER and PSP Elmo Angele, SDCER Phil West, GL Committeeman Bob Bybee, Oregon SP Ernie and Lola Zielinski, and Oregon Secy. Orville and Jeanne Mull. Both Brothers Klein and Hise addressed those present at the convention banquet. A golf tourney for men and women was also on the social calendar. A special tribute was paid to W. C. Rullman, who had served as President of the Idaho State Elks Association in 1930-1931.

It was reported that the Idaho Elks Rehabilitation Hospital, the state major project, treated 541 inpatients and 1,870 outpatients, with an average occupancy of 85.4 percent. Using state association dues, 34 "guest" patients were treated last year. The year's budget was \$1,590,000. The "C" Note Club, a fund which supports the hospital, has grown to \$104,390 of which only the interest is used. In addition, the Food Caravan, in its second year, obtained \$17,000 in foodstuffs and cash for use by the hospital. Another \$1,500 was received from the hide program. Expenditures by the state Elks for other charities exceeded \$60,000.

The state association will hold a semiannual meeting January 20-21 at Moscow. Pocatello was named as the location of the 1978 yearly meeting scheduled for June 22-24.

THE PENNSYLVANIA ELKS surpassed their goal by raising some \$257,456 for their major project, the Cerebral Palsy Home Service Program. The state Elks were congratulated for this achievement during their annual convention which was held June 10-12 at the Penn Harris Motor Inn, West Shore Harrisburg. It was also reported that contributions to the National Foundation totaled \$93,928.

Following the reports of the various committee chairmen, state sponsor PGER E. Gene Fournace and then-Grand Secy. Homer Huhn, Jr. witnessed the election of new officers. Those chosen included President C. Bennet Dry, Berwick; Vice President Carlon O'Malley Jr., Scranton; Secy. Howard Schran, Etna, and Treas. Joseph Waroquier, Clearfield. Ritualistic honors were awarded to the team from Pottstown Lodge.

An annual fall workshop was planned for September 9-11 at Seven Springs in Champion. On June 8-11, 1978, the Pennsylvania Elks will gather in Monroeville for their yearly conclave.

NEWS OF THE LODGES

(Continued from page 30)



PER FRANCIS X. McKeough (left) recently installed his father Charles (center) as Treasurer of Palm Springs, CA, Lodge. On hand to offer congratulations to the elder Brother McKeough was ER M. C. Manthey.



THE COLT LEAGUE baseball team sponsored by Lake Havasu City, AZ, Elks attended a dinner given by the lodge in their honor. Dick Parks (second from left), president of the league, and Youth Chm. Ed Frederico (fifth from left) passed out trophies to team members (from right) Kent Schulte, assistant manager, Kevin Mycek, Todd Vettraino, Sean Caldon, Rick Lynch, Jeff Wade, and Joe Behmer who won the league championship.



THE AMERICANISM Committee and other members of Provo, UT, Lodge chose patriotism as the theme of their entry in a local parade. The finishing touches were applied to the float by Brothers before the festivities began.

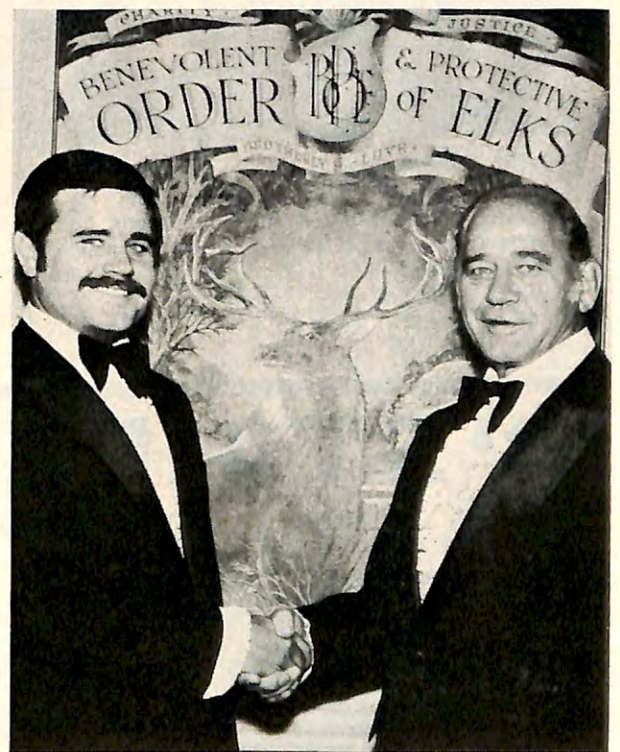

FOLLOWING his appointment as District Deputy, Robert Burke (right) visited his home lodge in Ukiah, CA. A younger Robert Burke (left), who was recently installed as Exalted Ruler of the lodge, welcomed his father and exchanged congratulations with him.



WHEN the Alameda-Contra Costa Medical Association Bloodmobile arrived at Alameda, CA, Lodge, it was met by a contingent of donors. Blood Bank Chm. Joe Koons (center) and committeemen (from left) Ray Rivamonte, George Boyd, ER Grant Eaton, and Oscar Zeisz were able to organize a successful drive—31 pints of blood were donated by the lodge Brothers.



BURBANK, California, Lodge has recently begun sponsorship of a new softball team, the "Bionic Babes." Sporting their new uniforms, the youths met with Baseball-Softball Chm. Scotty Sinclair (back row, left), Mary Dastolfo (second from left), coach, the team's lodge sponsor Alf Woodbridge (right), and Coaches Tony Dastolfo (bottom row, left) and Ken Kosiba (right).



FOR THE SECOND time in less than a year, the local U. S. District Court invited Albuquerque, NM, Lodge to participate in a naturalization ceremony. Among the 94 new citizens was Jose Luis Teixeira (fifth from left) of Portugal, who was congratulated by (from left) Brother M. A. Campagna, guest speaker, Americanism Chm. Tom Smith, Jesse Casaus, court clerk, Judge H. Vearle Payne, Justice H. Vern Payne, Committeeman Herman Heath, and Est. Lead. Kt. Frank Love.



A TROPHY in honor of the nine years that Hillsboro, OR, Lodge has supported the pigtail-ponytail girls softball league was presented to Youth Chm. and Est. Lect. Kt. John Lytle, Sr. recently. Presentations were also made to Gerri Smoole, the Teeny Bopper all-star, and to her father, Coach Dale Smoole, a Brother of Hillsboro Lodge.



THE REGAL elk's head and rack of antlers held by ER Ron Williams (right) and Brother Art Hayes, both Lompoc, CA, Elks, was a gift to Lompoc Lodge from Virginia City, MT, Lodge. During a fishing vacation in Montana, Brother Hayes received the gift from DDGER Karl Sauerbier and PER Laurence Elser, who also made Brother Hayes feel at home in their lodge.

"STAINLESS" STEEL

- MONEY CLIP
- NAIL FILE
- KNIFE

... with
ELK
EMBLEM

RICHLY MODELED BAS RELIEF
IN THREE COLORS



I ENCLOSE (CHECK, MONEY ORDER)
FOR ELK STAINLESS STEEL KNIFE
KNIVES UNLIMITED
P.O. BOX 2959, PROVIDENCE, RI 02903

NAME _____

ADDRESS _____

CITY _____ STATE _____ ZIP _____

ACTUAL SIZE

**STAINLESS STEEL
THROUGHOUT
\$5.00 EACH**

**POSTPAID
MONEY BACK
GUARANTEE**

MAJOR PROJECTS

This is the first in a series on the state major projects. Featured here are the major projects of Florida, Michigan, and Illinois, whose booths were prizewinners at the recent Grand Lodge Convention. State chairmen will be contacted to supply information for upcoming articles.

A car accident left little Mamie Ruth with severe brain damage—unable to feed herself, sit alone, walk, or speak, and partially paralyzed. After months of physical and speech therapy and intensive nursing care, she has begun to regain her physical capabilities. Mamie Ruth is just one of the youngsters helped at the Harry-Anna Crippled Children's Hospital, the major project of the **Florida Elks**.

For 44 years the Elks of Florida have owned, financed, and operated the Harry-Anna Hospital as a charitable, non-profit institution. The original hospital was a former hotel in Umatilla, FL, donated by Brother Harry Miller and his wife Anna. It eventually moved to temporary quarters in Eustis, and is now centered in a new, 2¼ million dollar facility in Umatilla. To finance the construction, the Building Fund Committee issued a directive giving each lodge an objective of \$40 per member. Humanitarian foundations in the state also contributed.

The new hospital, dedicated on March 26, 1977, is equipped to treat children from infancy to 15 years of age. The certified active medical staff consists of a general practitioner, a pediatrician, a neurologist, and 9 orthopedic surgeons. Physical therapy is the hospital's major supportive service. Other types of services available include X-ray, laboratory, eye care, recreational therapy, and dental care. A "home away from home" atmosphere is the aim of the 100-bed facility's cheerful decor.

Before a patient is admitted to the hospital, interviews are conducted to determine eligibility for admittance. No charges are made to the patient, and cost factors are 58 percent lower than other hospitals in the area. After discharge from the hospital, the patient's progress is followed up on an outpatient basis.

The Florida Elks have not only shouldered the cost of building the new Harry-Anna Crippled Children's Hospital, but also have taken on the obligation of maintaining it. Their aim is to make a nearly

normal life possible for the little people who come to them for help.

Physically handicapped children ranging in age from infancy to 21 years, as well as some adults, with orthopedic, orthodontic, sight, and hearing problems have found a helpful, empathetic advocate in the **Illinois Elks Association's Crippled Children's Commission**. Composed of 13 members and headed by a full-time director, the Commission acts as a liaison between the handicapped and the hospitals. Clinics are sponsored in various lodge areas, with 101 clinics scheduled for this year. Wheelchairs, walkers, braces, crutches, and the like are also made available by the Elks.

The work of the Commission is supported by Elks throughout the state. Each lodge has a crippled children's chairman, and there are also district chairmen. In addition, many volunteers assist at the clinics. All lodges participate in raising funds for the operation of the Commission. Per capita donations of \$2.00 per member are hoped for. There is also a 10¢ per member assessment for 1977-1978. Besides the annual statewide mail fund-raising appeal, seven districts collaborate on a yearly raffle. Events such as dinners, charity balls, and stags are held by the individual lodges to benefit the project.

In 1976-1977, some \$80,000 was expended directly on Illinois youngsters unable to obtain aid from any state-supported agency, and \$21,000 went into scholarships for physical therapy students. This year's \$165,000 budget will assure that the Illinois Elks Crippled Children's Commission will continue to be a "friend in need" to the physically handicapped children of the state.

On December 1st in **Michigan**, each of the 74 Elks lodges puts up a Christmas

tree and asks its members to trim it with ornaments purchased from the lodge. The tree-trimming profits, along with funds from other events and a voluntary one dollar donation per member, finance treatment for any handicapped Michigan resident who is from one month to 18 years of age and cannot obtain assistance from other agencies. Aid for handicapped children is the Michigan Elks major project.

The project is controlled by a Board of Commissioners elected from the eight districts to serve five-year terms without monetary compensation. They hire a professional, the executive director, who is at the center of the 20-year-old program. He processes applications, issues authorization on accepted cases, pays the bills, and reports to the Board.

Where does the director find the applicants? Each lodge has a major project chairman who contacts local families with handicapped children. He visits a family in need of aid and has them fill out an application. He also observes the family's problems and determines if they can contribute to treatment costs. His report and the application go to the director.

The application is considered by the major project commission in terms of the cost of care and treatment, the likelihood that assistance will result in correction of the handicapping condition, and the evidence that no other help is available to the child. A "handicap" is defined by the Elks project as "any defect or deformity in a child that restricts his ability to function in a normal manner." The need for wheelchairs, hearing aids, and other such devices, as well as services which are essential to treatment, such as therapy and boarding care, are all in the realm of available aid.

The purpose of the major project "is to help the child to become a self-sufficient, healthy, contributing citizen." In the past year, 502 children received treatment paid for by the Elks; \$193,796 of \$234,353 raised was spent directly on medical assistance. As an organization which likes to be known as the last resort, the people to go to "when no one else will help," the Michigan Elks major project certainly accomplishes an important goal. ■



Michigan Elks sponsored youngsters' trip to a camp for diabetics.

Harry-Anna Hospital



ELKS NATIONAL SERVICE COMMISSION

"So long as there is a disabled veteran in our hospitals, the Benevolent and Protective Order of Elks will never forget him."



Honor Roll

of District Deputies 1976-77

The Elks National Service Commission is privileged to list the outstanding District Deputies and State National Service Committee Chairmen whose leadership produced 100 percent participation in the 1976-1977 Veterans Remembrance Achievement Contest. We further acknowledge our gratitude to Grand Lodge State Associations Committee Chairman Richard W. Squires who supervised this significant contribution to the welfare of America's hospitalized veterans. We record with pride the accomplishments of the following 1976-1977 District Deputies:

Charlie B. Webster/AZ East Central Dist.
John R. Gibson/AZ North Dist.
William E. Rogers/AZ Southeast Dist.
Vernon E. Bethany/AZ Southwest Dist.
Robert L. Granger/CA Bay Dist.
Frank V. Johnson, Jr./CA Central Dist.
Larry Craven/CA East Central Dist.
Julius B. Girard/CA Inland Dist.
Ned E. Vento/CA Metropolitan Dist.
Edwin V. Loudon/CA North Dist.
Willis F. Dillon/CA North Central Dist.
Kenton Nash/CA Northwest Dist.
Ross E. Barnes/CA Orange Coast Dist.
James K. O'Keefe/CA South Dist.
J. T. Bair/CA South Central Dist.
William D. Brunner/CA South Central Coast Dist.
Harold J. Smith/CA South Coast Dist.
Andrew W. Scherrer/CA Southeast Dist.
Henry P. Trincherro/CA West Central Dist.
Harry W. Spencer/CA West Central Coast Dist.
Clement R. Hackethal, Jr./CO Central N. W. Dist.
Dwayne Hillberry/CO Mountain Dist.
James C. Beckley, Jr./CO South Dist.
Nelson King, Jr./CT East Dist.
David F. Brady/CT Northwest Dist.
Merritt T. Laws/HI
Charles A. Shaddock/ID Central Dist.
D. Lloyd Broadhead/ID East Dist.
Henry J. Buhrmester/ID North Dist.
Donald J. Rainville/ID North Central Dist.
Gerald W. Nicks/ID South Dist.
Marc Chapman/IL West Central Dist.

Ernest N. Christoph/IN Northwest Dist.
George H. Albrink/KY East Dist.
Robert M. Bickett/KY West Dist.
Charles A. Walker/ME East Dist.
Robert E. Crabb/ME West Dist.
Charles W. Bradford/MD, DE, & DC Central Dist.
George M. Clear/MD, DE, & DC East Dist.
Terry L. Chrisman/MD, DE, & DC West Dist.
Gaetano T. Abuzzese/MA Circle Dist.
Ephrem Caron/MA East Dist.
Edward J. Mahan/MA East Central Dist.
Thomas E. Donlan/MA Metropolitan Dist.
Edward T. MacGilvray/MA North Dist.
Guistino Marsella/MA South Dist.
Frank A. Saccavino/MA West Dist.
William P. Williams/MA West Central Dist.
James L. Robbins/MI East Central Dist.
Fred William Tornquist/MI Southwest Dist.
Harold F. Carlson/MN Central Dist.
Norman E. Schultz/MN Metropolitan Dist.
Edwin E. Butterfield/NE Central Dist.
A. R. Walter/NE East Dist.
Kenneth C. Green/NE West Dist.
Billy K. Dedmon/NV South Dist.
Arnold R. Siegel/NJ Central Dist.
Charles Schoener/NJ East Dist.
J. Milton Crans/NJ East Central Dist.
Donald E. Wilson/NJ North Dist.
Frank J. McCann/NJ North Central Dist.
Joseph Popadich/NJ Northeast Dist.
Leroy F. Lippmann, Jr./NJ Northwest Dist.
Wilford D. Conn/NJ South Dist.

Joseph R. Magnotta/NJ South Central Dist.
Le Roy P. Teeple/NJ Southeast Dist.
Bernard Giehl/NJ Southwest Dist.
William J. DuPree/NJ West Central Dist.
J. N. Wilmer, Jr./NM Northeast Dist.
Willis S. Claus/NM Northwest Dist.
Earl E. Phillips, Jr./NM Southeast Dist.
William H. Fickes/NM Southwest Dist.
William B. Browning/NY Central Dist.
Thomas Earey/NY East Dist.
Richard C. Brisky/NY East Central Dist.
Wilfred J. Trombley/NY North Dist.
Robert E. Carville/NY North Central Dist.
D. Joseph Casey/NY Northeast Dist.
Greg Emery/NY South Dist.
Lynn R. Oliver/NY South Central Dist.
Fred T. Bartsch/NY Southeast Dist.
Frank Aloii/NY Southwest Dist.
Albert A. Danckert/NY State Capitol Dist.
Lionel A. Henderson/NY West Dist.
Beryl McMillen/NY West Central Dist.
John D. Koester/NC East Central Dist.
Harry L. Agner/NC West Central Dist.
Louis A. DeMars/OH Northeast South Dist.
Bill B. Marshall/OK Northwest Dist.
John C. Andrew/OR Metropolitan Dist.
Harry Steele/OR North Central Dist.
Dan A. Linhares/OR Northwest Dist.
James R. Winn/OR South Central Dist.
Leonard H. Kress/OR Southwest Dist.
Lloyd D. Yost, Jr./PA South Central Dist.
Clyde W. Nash/PA Southeast Dist.
William F. Casey/PA West Dist.
Frank L. Suffoletto/RI East Dist.
Arthur E. Brown, Jr./RI West Dist.
Buddy L. Ferguson/TX Gulf Coast Dist.
Jerome M. Wright/UT North Dist.
Woodrow F. Roberts/UT South Dist.
Lloyd C. Bowles/VT North Dist.
John P. Foley/VT South Dist.
Dick Mitchell/WA Metropolitan Dist.
Douglas Greene/WA Northeast Dist.
Norman B. Triplett/WA Northwest Dist.
Gerald A. Kesterson/WA Southeast Dist.
James B. Roberson/WA Southwest Dist.
Ernest Hamlin/WA West Central Dist.
Louis J. Vits/WI Northeast Dist.
Elmer Nelson/WY North Dist.



Sharing this honor are the following State Association Veterans Chairmen who had contest entries from every lodge in their states:

Kermit J. Bressner/AZ	Al Jacobs/NE
John F. Jordan/CA-HI	James E. Hanlon/NJ
*Charles H. Ingalls/ID	Duane Jacklin/NM
Edward J. Meier/KY	George Malekian/NY
Edward R. Twomey/ME	*Joseph Thibodeau/RI
Paul D. Helsel/	Bill Van Talge/UT
MD, DE, & DC	Philip J. Trachier/VT
Henry M. Gibbons/MA	Stan Sarver/WA

* deceased



This important contest will be conducted again this year. Because the designation "Contest" has discouraged smaller lodges from reporting their activities in competition with more affluent lodges, next year's title will be "Participation Report" with award recognition similar to the contest format. It is hoped to document every activity, however small. All District Deputies and State National Service Committee Chairmen are urged to qualify for honor roll recognition. The purpose of this contest is to place positive proof on record that the Elks are keeping their promise never to forget our hospitalized veterans.

FIND BURIED TREASURE

Find buried gold, silver, coins, treasures with powerful new electronic detector. Ultra sensitive. Penetrates deep into earth. Works through mud, beach sand, rock, wood, etc. Signals when object is detected.



Write for Free Catalog, treasure hunting tips and unusual souvenir coin. **Financing Available**

RELCO Dept. DD29. Box 10839, Houston, Tex. 77018



NEW FORMATS FOR FUN AND FUND RAISING

If it's an evening of fun or fund-raising. A Nite At The Races® offers a choice of THOROUGHBRED, HARNESS or GREYHOUND RACING on 16mm film in color and sound with official track commentary. PAST PERFORMANCE FORMATS are also available.

We provide all supplies needed. A kit includes 18 sealed racing films for playing six or more races, Race Programs, Mutuel Tickets for individual races and for the Daily Double, Quinella, Exacta, Numeracta, etc. Play Money, Computation Forms and simple step by step instructions are also included.

Write for brochure explaining every phase of operation including ideas and price schedule to implement the format desired.

a nite at the races, inc. 2320 Avenue U / Brooklyn N.Y. 11229
(212) 769-7355

**STOP DENTURE PAIN INSTANTLY,
HOLD PLATES COMFORTABLE—
TIGHT, PREVENT SORE GUMS . . .
with END-SLIP DENTURE ADHESIVE
DENTIST RECOMMENDED**

Dr. C., N.Y.: 'The answer I've been waiting for.' Dr. C., Fla.: 'Once in so many years a product comes along that really works.'

Sold on MONEY-BACK GUARANTEE

Only \$2.00 for 24 Upper or 24 Lower, Postpaid.

Order from: ENDSLIP, Box 35
AMESBURY, MASS. 01913, USA

\$..... enclosed. Send me.

..... UPPER LOWER

Name

Street

City State Zip

HERE'S HOW ANYONE CAN SUCCEED NOW!

Book (with above title) 160 pages of easy-to-use personal success methods as used by the most successful men and women in the world to attain wealth, leadership, power, popularity — revealed in 53 chapters from world-famous Proven Success Methods Library. Mail ONLY \$2 check, cash, money order (money-back guarantee). M. R. KOPMEYER, PUBLISHER P.O. Box 6302, Louisville, Ky. 40207

THE ORIGINAL BASEMENT TOILET

Genuine Porcelain

FLUSHES UP TO
SEWER OR SEPTIC TANK

-No Digging Up Floors-
INSTALLS EASY. ANYWHERE!



Write McPHERSON, Inc., Dept. E
Box 15133 Tampa, Florida 33684

PUBLISH YOUR BOOK!

Join our successful authors. Publicity, advertising, beautiful books. All subjects invited. Send for fact-filled booklet and free manuscript report.

CARLTON PRESS

Dept. ELK
84 Fifth Avenue, New York 10011

FLORIDA'S WEST COAST

At \$20,900 a doublewide mobile home in a waterfront community can be your best Florida retirement housing value. For more information write P.O. Box 340, Dept. 1247, Ellenton, Florida 33532.

HEARING AIDS

SUPER SAVINGS! Newest, Finest. All types. Buy DIRECT & save up to HALF! No salesmen. Sold by AIR MAIL on HOME TRIAL. FREE Catalog. Write: **MONEYSAVERS**, Dept. EK-11, 9530 Langdon Ave., Sepulveda, Cal. 91343

SAVE 1/2!

FREE CATALOG — WRITE!

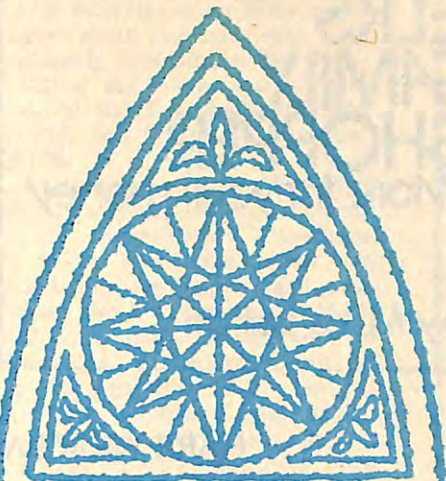

ELKDOM'S DAY OF REMEMBRANCE

Sunday, December 4, has been designated as Elks Memorial Sunday at which time we will honor the memory of our absent Brothers.

Competition will be held again this year as it has been in the past. Awards will be made to the top three lodges in each of the five membership divisions which, in the opinion of the judges, excelled in their Memorial Service Program. All phases should be properly documented with pictures and newspaper clippings. Entries will be judged on program, attendance, decoration, publicity, and appearance. Pictures may be posed before or after the program. Please do not send tapes.

Your lodge's tribute to its departed members should be worthy of their memory and of the Elks' tradition. Brochures covering these services must be submitted no later than Saturday, January 28, 1978, to:

John D. Sullivan, Member
GL Lodge Activities Committee
290 Midland Road
Southern Pines, NC 28387

Do not send any Memorial Sunday material to *The Elks Magazine*.

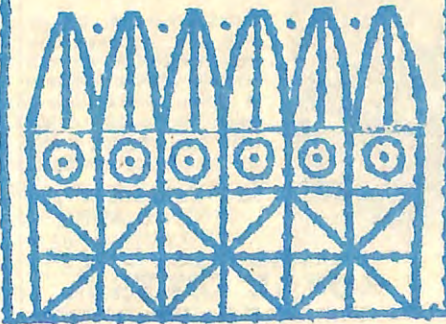

BINGO FOR FUND RAISING

EVERYONE HAS FUN!

No off nights when you use BINGO for your fund raising! Thousands of Organizations are making \$50 to \$500 per week using "BINGO KING" supplies with FREE Idea Bulletins. PAY AS YOU GO.

MAIL COUPON
TODAY!



BINGO KING

Dept. 711B, Box 2588, Littleton, Colorado 80120

Yes, show us how BINGO can make money for our Organization.

Your name

Address

City State Zip

Name of Organization

BE A LOCKSMITH



"Was never so enthused and delighted with lessons in my entire life. I grossed over \$3,000 in one year just working weekends."
Rocky Orsi
Azusa, California

You'll enjoy your work as a Locksmith because it is more fascinating than a hobby—and highly paid besides! You'll go on enjoying the fascinating work, year after year, in good times or bad because you'll be the man in demand in an evergrowing field offering big pay jobs, big profits as your own boss. Train at Home—Earn Extra \$\$\$\$ Right Away! Send for FREE booklet today!

LOCKSMITHING INSTITUTE
Div. Technical Home Study Schools
Dept. 1223-117 Little Falls, N.J. 07424

Name (Please Print)

Address

City/State/Zip

Check here if Eligible for Veteran Training

REDUCIBLE RUPTURE AGONY

REMOVED (or trial COSTS YOU NOTHING) . . . WHEN you slip into a low-cost, contour-designed Brooks Patented Air Cushion Appliance! Your reducible rupture will be held in securely yet gently. You can enjoy heavenly comfort night and day at work or play. Isn't this worth a no-risk trial? Write for free facts now. **BROOKS CO., 370 E. Mich. Ave., Marshall, Mich. 49068**



GUARANTEED LIFETIME GIFT!



Dr. Rihm Daily-Must Fitness Control Meter! Measures the exact amount one walks and indicates how much one should walk. Walking is recommended for lack of exercise, obesity, bad posture, muscle atrophy, poor circulation, diabetes, recuperation from heart attack, and restoration of physical fitness. Complete instructions & health ideas.

Only \$19.95 plus \$1 UPS.
HARVESTLAND CO. Dept. Ek11
PO Box 681, W. Chester, Pa. 19380

PEANUTS that are crunchier, meatier, more delicious than you've ever tasted. The Peanut Shop of Williamsburg presents peanuts that are distinctly unique and different. Peanuts cooked in a special way. A recipe handed down from generation to generation in the Virginia peanut country. Plump, extra large Virginia peanuts are carefully blanched, cooked in pure peanut oil in small batches and lightly salted. You get the natural flavor and goodness of the peanuts with no preservatives, no additives, nothing artificial.

Homestyle 2½lb. \$6.95
Homestyle 1 lb. 3.50



Add \$1.00 West of Mississippi or send for our catalog. Satisfaction Guaranteed

The Peanut Shop
of Williamsburg
MERCHANTS SQUARE
P.O. BOX 6N, WILLIAMSBURG, VIRGINIA 23185

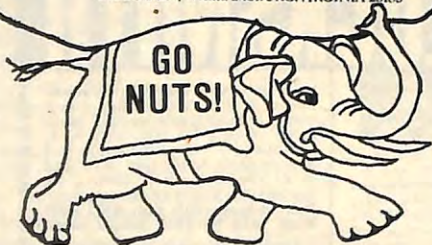

DO-IT-YOURSELF FINE FURNITURE KITS



- Heirloom quality
- Solid 3/4" hardwoods
- Easy to assemble
- Many models
- Money back guarantee
- Factory direct prices
- Prompt shipment



Send 50¢ for color catalog.
Refund on first purchase.

EMPEROR®
CLOCK COMPANY

WORLD'S LARGEST MANUFACTURER
OF GRANDFATHER CLOCKS

Dept. F-92 Emperor Industrial Park
Fairhope, Alabama 36532

ELKS FAMILY SHOPPER

More for your money

by Mike LeFan



MARK YOUR BARGAIN CALENDAR

Mark these savings on your November bargain calendar:

It's a moneysaving time to buy white goods, table linens, and blankets. Also check other housewares like china, glassware, and silverware.

November is a good month to buy if you want to save on heavy appliances like kitchen ranges and water heaters.

Save on women's clothing, especially coats, shoes, wigs, hats, and most winter items. Best buys in men's and boys' clothes are suits and shoes. Most children's clothing is on sale.

You'll find some buys on Christmas toys and bicycles this month. Used cars are cheaper in November. Otherwise, watch for savings at the Veterans Day and Thanksgiving sales.

Supermarket Snoop has a cart load of fresh produce bargains for November: Brussels sprouts, turnips, rutabagas, avocados, celery, parsley and herbs, sweet potatoes, broccoli, cauliflower, leeks, mushrooms, parsnips, pears, cranberries, tangerines, persimmons, and grapes.

Beef prices will rise in the next few weeks, warns our Supermarket Snoop. If you have freezer facilities, shop the weekly specials and stock up on beef now. You can also expect higher prices on dairy goods, and canned and frozen fruits and vegetables. Prices in the next few weeks should be steady on chicken, pork, bread, and cereal.

It's harder than ever to make a wise choice about your housing investment.

Learn the pros and cons of building or buying a house, renting, buying a condominium, and buying a mobile home. Order this 42-page booklet called *Your Housing Dollar*. Send 35¢ to Money Management Institute, Dept. MM, Household Finance Corp., Prudential Plaza, Chicago, IL 60601.

Still on the subject of housing, the American dream of owning a home is fading because of high building costs and high down payments. But there may be a solution. It's called "magic money," a term based on the initials of the Mortgage Guaranty Insurance Corp. (MGIC) which has provided "magic money" to over two million homebuyers in the last 20 years. There are other private mortgage companies, but MGIC of Milwaukee is the oldest and largest.

Private mortgage insurance may let you buy a home with a down payment as low as five percent, yet many people are unaware of the private mortgage concept. The median price of a single family home is now \$47,500. That means a down payment of \$9500 to \$12,000—a tough sum to save up.

But with "magic money" private mortgage insurance you can get that house with a down payment as little as \$2,375. The balance is provided by a savings and loan association, a mutual savings bank, or by a participating commercial bank. The mortgage is guaranteed by the "magic money" company. The insurance usually costs one percent of the mortgage amount

WANT TO KNOW HOW FAR YOU JOG?



Whether you jog, run, or walk, this precision DIGITAL PEDOMETER will accurately register distance in miles and tenths of miles, up to 100 miles. Light and compact, it fits on your belt or waistband.

Send just \$14.95 plus \$1.00 post. and hdlg. (N.Y. S. Res. add 4%)

Satisfaction Guaranteed

ROYAL GIFTS

P.O. Box 11-008, Dept. EL-117, Albany, N.Y. 12211

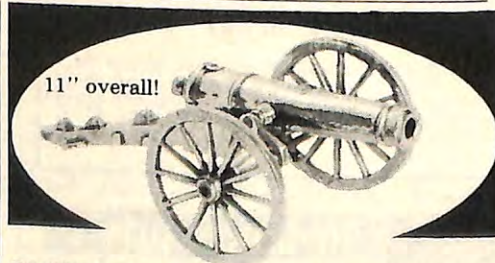

REVOLUTIONARY WAR FIELD CANNON
Sand-cast of solid brass. This authentic replica is perfect for desk or den! A wonderful gift! Only \$38.50 + \$1.50 postage & handling. Send check, Mastercharge or Visa Card number today to: Valleu Replicas & Rarities.
Dept. CE. Box 717, Saugatuck, MI 49453

(\$45,125 in our example) payable at closing time; in this case it's \$451, plus one-fourth of one percent annually on the outstanding mortgage balance.

You'd pay charges of less than \$150 a year until you pay off 75 percent of the loan. On a 30-year mortgage your MGIC payments stop after about 10 years when it's no longer necessary to guarantee your loan. Total cost of the loan is less than \$1500. Ask around about this if you're having trouble with high down payments.

Will a heat pump help you save on heating and cooling costs? The answer is "Yes—probably." With rising electric rates and the unavailability of natural gas for new homes in some areas, the heat pump may be the most economical way to go now. Get a free booklet explaining the details and advantages. Send a self-addressed, business-size envelope to Air Conditioning and Refrigeration Institute, Dept. HP-mm, 1815 N. Fort Myer Dr., Arlington, VA 22209.

Planning a Thanksgiving trip? It can be the time a good neighbor policy pays off, says Ira Lipman, president of *Guardsmark*, a leading security protection firm in New York. Lipman, author of the book *How to Protect Yourself from Crime* (published by Atheneum), says that neighbors willing to look after your house will do a lot to prevent burglaries and vandalism while you're gone. How? By making it look like you're home when you're not.

Give a neighbor the keys to any car you leave at home and ask him to move the car and park it differently every couple of days as if it were in regular use.

Get your neighbor to come over and turn on lights at dusk—just as if you were home—or buy a couple of automatic timers to turn lights off and on. Otherwise, leave one or two lights on while you're away. And see if your neighbor will pick up newspapers, mail, milk, or other items that might accumulate at your door. Now, be sure to offer your services to the neighbor when he leaves town.

Some doctors are publishing a monthly health newspaper called *Good Health*. It uses everyday English to answer health questions, give helpful

tips, and educate in an entertaining way. Learn about your body, diet, exercise, disease, sexuality, health insurance, aging, and more. A year's subscription is \$3.95 from *Good Health*, Dept. MM, 244 Collins St., Hartford, CT 06105.

A new adapter called *Killer Watt* converts energy-guzzling incandescent lamps to moneysaving fluorescent bulbs. Some new table lamps are equipped with the adapter, and catalog houses like J. C. Penney and Montgomery Ward feature *Killer Watt* in their catalogs. The adapters sell for \$12 to \$25, depending on whether you get a single or double bulb model. *Killer Watt* screws into any regular lamp socket or fixture and uses standard circular fluorescent bulbs.

A single 19-watt unit gives the light of a 60-watt incandescent bulb—a two-thirds savings of electricity. While the average incandescent bulb burns about 750 hours, a fluorescent lasts about 12,000 hours. Get a free brochure on the *Killer Watt* by sending a stamped, self-addressed envelope to The Killer Watt Corp., Dept. MM, 2638 Yates Ave., Los Angeles, CA 90040.

What cheese is nutritious, tasty, versatile—and inexpensive? Cottage cheese, of course. It's also low in calories. Have you tried it as a sandwich filling? It goes well with chicken, thin sliced roast beef, ham, turkey, or tuna. Try it with chopped hard-boiled eggs on toast, or with minced green pepper, a little tomato, and a hint of green onion. For the more adventurous, I hear that cottage cheese teams well with peanut butter or with jelly. But you'll have to try that for yourself.

Have a tip for "Money Saver of the Month"? Then send it to me. If I use it, you'll get a small prize.

Money Saver of the Month: If you're a do-it-yourself motor oil changer, you probably have trouble getting rid of old oil. Here's a good way to get rid of it and do some good too. Use it to dress out dirt roads, lanes, or alleys to cut down dust or erosion. You're welcome.

Send questions and tips to Mike LeFan, c/o *More For Your Money*, 425 W. Diversey, Chicago, IL 60614.

The Ultimate in Personalized Jewelry **Picture Pendant**



actual size

Your favorite photo is copied and permanently inlaid in an elegant pendant

Elegantly sculptured, styled oval, finished in antique pewter with 24" sterling silver chain; or antique brass with gold-filled chain. Inlaid exact reproduction of any color or black-and-white photo, sealed with lifetime clear polymer. Original photo returned unharmed.

Marvelous Personal Gift for Her or Him!

Any photo can be inlaid in a Picture Pendant: boyfriend, girlfriend, husband, wife, children, grandchildren, even a favorite pet! Each pendant comes in its own gift box, ready for giving.

Your Photo or Slide Carefully Copied

All detail retained; enlarged or reduced as needed; meticulously hand-cropped; painstakingly inlaid. Fine jewelry you'll proudly wear. When not wearing it, display Picture Pendant on special miniature easel included with each order.



To Order Your Picture Pendant

Send photo, print, or slide, and \$19.95 for each Picture Pendant. Specify pewter or brass finish. Add \$1.00 for shipping. Illinois residents add \$1.00 sales tax. Use check, money order, or bank card. No C.O.D. Allow 3-4 weeks for delivery. For best service, put name and address on back of photo.

Lewis and Clarke Originals, 509 S. Vermont St., Palatine, Illinois 60067

MONEY BACK GUARANTEE

- Please custom make my Picture Pendant in:
- Antique Brass Antique Pewter
 - Enclosed is \$19.95 plus \$1.00 for shipping. (Illinois residents add \$1.00 sales tax)
 - Charge to my Master Charge Visa card no. _____ expires _____

Name _____

Address _____

City _____ State _____ Zip _____

For orders of more than one Picture Pendant, please state desired finish for each photo submitted. E 1
LEWIS AND CLARKE ORIGINALS
509 S. VERMONT ST., PALATINE, ILL. 60067



14K SOLID GOLD FROM ITALY Special Low Prices For Elks

Treat yourself or give for Christmas. A. 16" necklace \$16.95, 18" \$19.95, matching bracelet \$15.95. B. 16" necklace \$23.95, 18" \$26.95, matching bracelet \$21.95. C. 16" necklace \$28.95, 18" \$31.95, matching bracelet \$19.95. Postage Paid, Satisfaction Guaranteed. Midas Touch, 850 Hartzell, Pacific Palisades, Calif. 90272.

RECANE Your Favorite Chairs EASILY

Chairs with groove in frame
Cane Kit—12"x12" \$ 6.00
Cane Kit—18"x18" \$ 8.00
Cane Kit—24"x24" \$12.00

Chairs with holes in frame
Hand weaving Kit \$7.00
Fibre rush chair Kit—\$6.70

Instructions included in all Kits.
Wash. res. add 5.4% sales tax
catalog .35 p.p.d.

**NORTHWEST
CANE SUPPLY**
8010-15 ave. N.W.
Seattle, Wa. 98117



TALL EXTRA TALL & BIG MEN TALL

FED - UP WITH CLOTHING STORES

Sick of searching for your size, only to find last year's styles at this year's prices . . . and they still don't fit? Step into a "clothing store" that specializes in you. Where everything is in your hard-to-find size and is proportioned to fit you comfortably and correctly or your money back. You've never seen anything like The KING-SIZE Co. catalog . . . brand name clothing and shoes for Tall, Extra Tall and Big Men exclusively. Send for your Free Copy Today to look your best in the styles you want and the sizes you need. We guarantee to fit you, even in suits . . . or money back.



SEND FOR FREE CATALOG

My Telephone Number _____ Area _____
 Height _____ Weight _____ Shoe Size _____
 Name _____
 Address _____
 City _____ State _____ Zip _____
 The King-Size Co. 2387 King-Size Bldg.
 Brockton, MA 02402

If you can use a screwdriver and drill . . . you can

BUILD YOUR OWN HEIRLOOM GRANDFATHER CLOCK



at 50% or less of retail price

- Solid 3/4" kiln dried wood
- Fully Assembled/precision-made West German Movements

WRITE NOW FOR FREE Color Brochure of complete line of Grandmother, Grandfather and other clocks.

HENTSCHEL clock company
 Department 8-ELN
 16 Atlantic Avenue
 So. Dennis,
 Mass. 02660



Cheney. Because Carol loves this house.

Carol's illness prevented her from climbing these stairs like she used to. She could move to a one-story house, but she loves this house. A Cheney Weclator™ solved Carol's problem by letting her ride from floor to floor quickly and comfortably. As the first stairway elevator to be UL-listed, it's virtually maintenance-free and can be installed in just a matter of hours. For a colorful brochure on Cheney Weclators, or Wheelchair Lifts and Wheelchair Van Lifts, contact your local Cheney Representative or write: The Cheney Company, Dept. EM, 3015 S. 163rd Street, New Berlin, WI 53151. (414) 782-1100.

Helping people help themselves.
CHENEY Weclators.

JUMP'N'JOGGER

The Fun Way To Exercise

Exercise as Doctors do to lose weight. Keep physically fit.



\$11995

Calif. add 6% sales tax

Only seven inches high

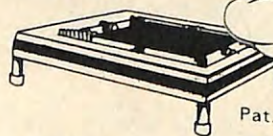

Pat. Pend.

HACKER ENTERPRISES
 P.O. Box 711, Glendora, Ca. 91740
 Dealer inquiries welcome



TIMELY WRIST CALENDARS Fit any standard watchband. Reversible gold or silver finish with large, easy-to-read numerals that won't wear off. Forms to fit wrist, won't wear out your cuffs. This inexpensive handsome 12-month set is only \$1.75 postpaid. Specify starting month. Order from MBM Company, Box 1646E, Mason City, Iowa 50401.
 Iowa residents add 3% sales tax.

Elks Family Shopper



COIN COLLECTOR'S TREASURE. U.S. Coins are sold by the pound and a gold piece of the world is included. All coins are 30-150 years old; may include Indian, Lincoln cents; silver dollars; 2¢; 3¢; etc. 1 lb. for \$16.50; 2 lbs. \$30; 5 lbs. \$72. 10 lbs. (plus 2 gold pcs.), \$115. Add \$1.50 shpg. Centre Coin Co., Box 1, Dept. L-11, Sherman Oaks, CA. 91413.



BEAN'S OVER-THE-SHOE BOOTS keep men and women's feet dry during cold snowy months. Men's is 9" high leather upper with genuine wool pile lining, full waterproof sole, Mahogany. Sizes 7 to 13. \$45.00 ppd. Ladies 8" high in coffee cream; sizes 5 to 10, \$36.00 ppd. Whole sizes only. L. L. Bean, Inc., Dept. 7180, Freeport, ME. 04033.

COLLAR EXTENDER

Eases Tight Shirt Collar Discomfort

10 for \$1.75

plus 25¢ postage
 2 Sets of 10 for \$3.25 ppd.



Collar fit tightly due to shrinkage, washing, starching, growth, weight increase? Add up to 1/2 size for just-right fit instantly. Slips on and off in seconds. Ideal for men and growing boys. Send check or M.O.; no C.O.D.'s 21-day money-back guarantee.

BARCLAY, Dept. 51-MA

1575 No. Dixie Hwy., Pompano Beach, Fla. 33060

SLEEP WARM—SAVE FUEL

You Sleep ON IT not under it



New **BED WARMER** goes on the mattress. Enjoy soothing, relaxing radiant heat from below. More comfortable and convenient than electric blankets. Yet, **COSTS LESS** to operate. Drives out cold and dampness.

SAVE FUEL by turning your furnace low at night, and still sleep warm. Automatic thermostat adjusts bed warmth for any changes in room temperature. Six sizes for home use, plus 12 volt models for RV's and sleeper cabs. Also auto seat, chair and pet warmers. Send for **FREE** booklet. Describes all Electro-Warmth® products, advantages & savings. Great for gifts, too.

PATENTED PRODUCTS CORP.

Dept. E-1177

Danville, OH 43014

THE MOST ASTOUNDING **Waistline Reducer** OF ALL TIME!

Astro-Trimmer™

IS PRODUCING FANTASTIC 'TRANSFORMATIONS' LIKE THIS
...IN JUST 3 DAYS...WITHOUT DIETING...IN JUST MINUTES A DAY!

**GUARANTEED TO REDUCE YOUR WAISTLINE
2 TO 5 INCHES IN JUST 3 DAYS—OR LESS
OR YOUR MONEY BACK!**

Fred Masters—"No matter what I tried—dieting, exercise—I was never able to get rid of the roll of excess inches around my mid-section. Then Astro-Trimmer came along and reduced my waistline 6 full inches—from 38½ to 32½ inches—in just 3 days without dieting. The inches have never come back! This has to be, without a doubt, the world's greatest inch reducer!"

HERE IS HOW IT WORKS:



Fred wraps the Astro-Belt completely around his waistline, before hooking the Astro-Bands to a convenient doorway. He is then ready to perform one of the pleasant, marvelously effective Astro-Trimmer movements—just about 10 minutes.



Now Fred simply relaxes a few moments with his Astro-Belt in place. His Astro-Trimmer movements have triggered the Astro-Belt's incredible inch-reducing effect which goes on working even as he relaxes.



After his brief period of relaxation, Fred removes his Astro-Belt. His waistline is already tighter and trimmer. Fred lost over 3 inches on his waistline the very first day—and 6 full inches from his waistline in just 3 brief ten minute sessions.

AFTER
Fred Masters
... 6" off
waistline in
just 3 days

Startling discovery—the Astro-Trimmer has got to be the most sensationally effective and the most fun to use slenderizer of all time. It is a marvel of ease, comfort and efficiency—and a pure joy to use. The Astro-Trimmer's totally unique design consists of a double layered belt; a soft nonporous inner thermal liner which wraps completely around your mid-section producing a marvelous feeling of warmth and support—and a sturdy outer belt that attaches you to the super duo-stretch Astro-Bands which you hook to any convenient doorway. These duo-stretch bands enhance your slightest movements and transmit their effect—greatly magnified—directly to the inner thermal liner of the belt to produce an absolutely unequalled inch-reducing effect. In fact, for sheer inch loss, the Astro-Trimmer is supreme. Try it for yourself—at our risk—just slip on the belt, hook it up, stretch and perform one of the easy-to-do movements in the instruction booklet and watch the inches roll off. Men and women from 17 to 70 in all degrees of physical condition are achieving sensational results from this ultimate inch-reducer. Results like these:

G. Fuller—"Using the Astro-Trimmer just a few minutes a day, I lost over 4 inches from my waistline in the first 3 days. It's just incredible."

T. Greer—"My waist actually came down 5 full inches in 5 days—from 38 to 33. My entire physique looks so much better and I feel so much better that I can't praise this sensational trimmer enough."

J. Morgan—"Remarkable results from a remarkable product. With the Astro-Trimmer I actually reduced, firmed and tightened my waistline 5 inches—from 33¼ to 28¼—in just 3 days—without dieting. Not only has my appearance improved tremendously, but I feel so much better and seem to have so much more energy than before."

How many excess inches can I lose with the Astro-Trimmer? How many excess inches do you have? Many users lose 2 or more inches from their waists and 2 or more inches from their abdomens the very first day. Three, four, even more inches off the waist in three days is not uncommon. Not everyone will do this. The degree of inch loss will vary with individual body response. However, this matchless body shaper melts excess inches off the waist, abdomen, hips, thighs with such amazing speed that if your waistline isn't 2 to 5 inches trimmer after using your Astro-Trimmer for just 3 days—or less—and if you don't lose these inches without dieting and in only 5 to 10 minutes a day, you may simply return your Astro-Trimmer and your money will be refunded.

No risk—no obligation—money back guarantee. So-called "waist trimmers" and reducers are now being nationally advertised for from \$19.95 to \$49.95. Yet the sensational new Astro-Trimmer—which trims and slims excess inches far faster, far more effectively than anything we have ever seen—is being offered for only \$9.95 with a complete money back guarantee. If you are not satisfied that the Astro-Trimmer is the fastest, the most effective waist reducer you have ever used, it will not cost you a penny. So if you want a trimmer, more dynamic body—right now—send for your Astro-Trimmer today.



BEFORE

**ORDER NOW FOR A SLIMMER,
TRIMMER WAISTLINE THIS WEEK!**

PAT. PEND
© Copyright Astro-Trimmer 1977
Highway 1 and Callendar Road, Arroyo Grande, CA 93420

Astro-Trimmer™ P.O. Box 3140, Dept. EK-2, Monterey, Ca. 93940

Please send me Astro-Trimmers along with complete easy-to-use instructions. I understand that if I do not lose from 2 to 5 inches from my waistline in just 3 days I can return my Astro-Trimmer and receive my money back. I enclose \$9.95 for each Astro-Trimmer plus 90 each for postage and handling. PLEASE CHARGE TO MY:

Check Money Order No COD's accepted BankAmericard Visa Mastercard Exp. Date

Charge Account No. _____
M/C Interbank No. (on card above name) _____
Man: waist size _____ Woman: waist size _____
Name _____
Address _____
City _____ State _____ Zip _____

PERSONALIZED TRAVELER

Embroidered monogram included at no extra charge!

Personalize your Christmas gifts with this handsome Traveler beautifully embroidered with a distinctive monogram!

Made of strong, lightweight, water-repellent fabric, 65% polyester, 35% cotton. Holds 3 suits or 6 dresses without creasing. Full length side zipper for easy access. Men's: 40" long. Ladies': 50" long. Ladies' formal: 60" long. In navy, black, ale, brick or red. 3 weeks delivery. 10-day money-back guarantee.

Men's: \$14.00. Ladies': \$16.00. Formal: \$18.00. 3 initials or name up to 4 letters monogrammed free. Add \$3.00 for set of 3 contour-handled travel hangers. No C.O.D.'s. N.Y. State residents add sales tax.

Add \$1.00 per order for postage and handling.

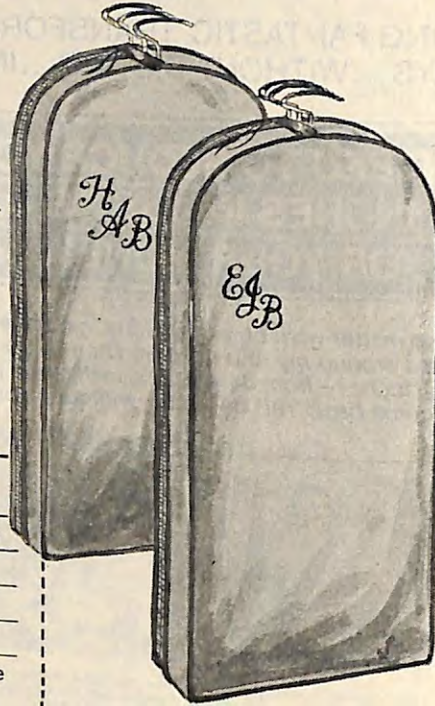

TRAVEL SPECIALTY CO. Dept. E
350 Fifth Ave., New York, N.Y. 10001

Please Print	Color	Initial or name
Men's		
Ladies'		
60" Formal		

Additional \$3.00 enclosed for set of three Travel Hangers.

Check enclosed.
(Add \$1.00 if more than 4 letters in name.)

Name _____
Address _____
City _____ State _____ Zip _____



A PERFECT CHRISTMAS GIFT

This natural finish Sand Dollar pendant on a 24" gold clasp chain is an ideal conversation piece. This real shell, found in the Gulf of Mexico is 2 to 3 inches in diameter and has

been treated and hardened by a special process. We will mail this Sand Dollar to you in an attractive gift box along with the story of this Holy Ghost shell. An ideal gift for the hard to please person. Send only \$6.00 check or MO PPD to

MJ SAND DOLLARS®
Box 5657, Sarasota, Florida 33579

GREENHOUSES

from \$88⁹⁵!



Uses up to 40% LESS HEAT !!

All-bolted California Redwood and Fiberglass. Portable. Write to McGREGOR GREENHOUSES, Box 36-11B, Santa Cruz, CA 95063. (408) 476-5390

FAMILY GREST RINGS



Ring #11
16x14mm top
Solid 14k Gold
\$195.00

Sterling Silver
\$90.00

WE WORK IN THREE BASIC WAYS

1. If you do have a coat of arms, just send us a photograph or picture of it and that is what we engrave.
2. If you do not have a coat of arms send us your name and we'll look it up for you at no extra cost, or you may check it against our list (see below).
3. If you wish you may design your own coat of arms.

SEND FOR OUR FREE COLOR CATALOGUE
If, in addition to our free catalogue you wish to get our booklet containing over 20,000 names for which we have records of coats of arms and for which this jewelry is available, plus instructions on "how to design your own coat of arms". SEND US \$1.00.

HERALDICA IMPORTS, INC. Dept. EL
21 WEST 46th ST. NEW YORK, N.Y. 10036

BUSINESS CARDS FOR CHRISTMAS

RAISED LETTERS—THERMO-ENGRAVED
BUY DIRECTLY FROM THE MANUFACTURER
250 cards same copy \$8.00
500 cards same copy \$9.00
1000 cards same copy \$10.00
3000 cards same copy \$25.00
3 DAY SERVICE

Brilliant Black Ink on Ultra White Stock
Send your copy or present card and let our staff of experts prepare your new card, or write for free order form and samples. BPOE Logo and lodge number if desired.

Also wedding and social or business announcements from \$12.00 per 100. Send \$1.00 for samples, refundable with order.

Cards Sent Postpaid—Fla. Res. Add 4% Sales Tax
SEND CASH, CHECK OR MONEY ORDER TO:
Palm Beach Thermo-Graphics
DEPT. E-2, P.O. BOX 3797
WEST PALM BEACH, FLORIDA 33402

Elks Family Shopper



TUMBLER WON'T TUMBLE OVER for it's designed to reduce spills. Tumble Not Tumbler™ has a catch ring to prevent it from upsetting; also easy to pick up and handle. Kids and their mothers love it. Great for arthritics, those with poor sight. \$2.40 ppd. Specify red, blue or green. Tumble Not Tumbler, Inc., P.O. Box 66EM, Loogootee, Ind. 47553.



YOUR FAMILY TREE can be recorded on 50 unique family generation charts designed for over 500 years of family history. Rich leathertone volume has paper treated to last for generations. Volume, 50 charts, \$9.95 plus 75¢ shpg.; 2/\$17.95 ppd. (N.Y. res. add sales tax.) Intl. Home Library, Dept. EK-2, P.O. Box 324, Greenlawn, N.Y. 11740.



GIVE A SURE WINNER this Christmas. Your favorite filly will love beautifully finished Horse Jewelry. Set of two horse pins and matching bracelet with handsome horses has a high silver finish with darkened details. Only \$6.95 plus 50¢ shpg. Matching Earrings only \$3. J. W. Holst, Inc., Dept. EH-117, 1864 E. U.S.-23, East Tawas, Mich. 48730.

GREAT GOLF GIFT

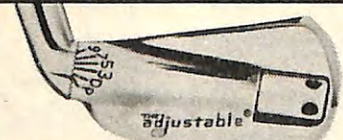

The Adjustable® is a great club for practice, travel, par 3 courses, when the course is too wet for a cart, or when you're just plain tired of toting a bag full of clubs. Adjusts to driver, 3, 5, 7, 9 iron and putter. Only one club to carry, master, and enjoy. And finish your round feeling fresh, not tired! Top quality product.

Regularly \$44.90; **Special Christmas offer \$38.95 Ppd. 2 for \$73.95.** Money back guarantee. For Visa and MasterCard send number and expiry date or order toll-free 800-621-8318 (Illinois residents 800-972-8308). Specify right or left handed and height for proper club length.

INTERNATIONAL GOLF PRODUCTS
1865W Campeau St. • South Bend, IN 46617

Elks Family Shopper



FEET FEEL SO FREE as you sleep with Folding Deluxe Blanket Support to hold sheets and blankets off your feet. Lifts regular, contoured or electric blankets. Also holds bedspread and covers until needed. Arms fold invisibly flat when bed is made. Ideal for arthritics, convalescents. \$8.98 ppd. Better Sleep Inc., Dept. EL11, New Providence, N.J. 07974.



1,000 ALL-DIFFERENT POSTAGE STAMPS from over 55 countries include Space, Olympics, Kennedy. Worth over \$30 at Standard Catalog prices; yours for only \$2.95 to introduce approvals. Buy any or none, cancel service anytime. Included free, 80-page Collector's Catalog. Kenmore Co., FM964, Milford, N.H. 03055.



CLASSIC COBBLER'S LAMP replica gives you intimate lighting for those special occasions. Fill glass balls with clear or colored water and light candle in center to create a warm, flickering glow. Wood frame, with split suede leather straps. \$15.98 plus \$1.99 shpg. (Ill. Res. add 5%) House of Minnel, Dept. E117E, 530 Lark St., Geneva, IL, 60134.



SILVER AND TURQUOISE ELKS RING. This beautifully designed ring, in the traditional style of the Southwest, combines silver (nearly one troy ounce of silver) and a genuine turquoise stone. A handsome piece of jewelry for an Elk and a good buy at only \$49.95 ppd. State ring size. Anderson Jewelry, 941 Avenida Manana, NE, Albuquerque, NM. 87110.

FOR COLLECTORS—INVESTORS—PROUD AMERICANS

THE OFFICIAL U.S. MINT ISSUE COMMEMORATIVE BICENTENNIAL COIN COLLECTION

24 KT GOLD PLATED

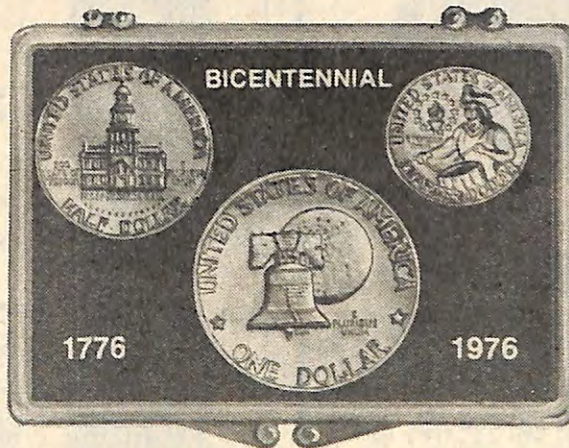

**ONLY
\$9.95
EACH**

The U.S. Mint has now stopped all production of Bicentennial 1776-1976 Commemorative Coins. This may be your last chance to own this magnificent set of 24KT Gold

Plated Coins. Authorized by an act of Congress for the first time in 200 years, this distinctive collection is both a unique investment opportunity and a lifetime heirloom gift to be passed down from generation to generation.

A very small number have been produced in 24KT Gold Plate. Our supply is very limited and this unusual offer may not be repeated.

All commemorative coins previously made by the U.S. Mint have increased in value—many now are valued at hundreds of dollars.

Each Treasure Set is beautifully displayed in a transparent dust proof Presentation Case on a royal blue background. The dollar features our beloved President

Eisenhower. The half dollar pictures John F. Kennedy and the quarter our first President George Washington. The reverse pictures for the first and only time the famous Liberty Bell and our Space Men landing on the moon.

Orders will be filled on a first come, first shipped basis until our limited supply is sold. Order now at our low, low price of just \$9.95 per set.

Order several sets now for Holiday gift giving.

We are members of the Retail Coin Dealers Association for 15 years — in business for over 25 years.

Novel Numismatics, Dept. EK-10
31 Second Avenue, New York, N.Y. 10003

Please send me the coin set(s) checked below. Enclosed is my check..... money order..... for \$..... as payment in full. (N.Y. residents please add sales tax).

- 1 Coin Set for \$9.95 plus \$1.00 p.p., hndl., ins.
- 2 Coin Sets for \$18.00 plus \$1.50 p.p., hndl., Save \$2.40.
- 3 Coin Sets for \$25.00 plus \$2.00 p.p., hndl., ins. Save \$5.85.
- 10 Coin Sets for \$75.00 plus \$3.00 p.p., hndl., ins. Save \$31.50.

Name

Address

City State Zip



Dri-Guard for "No Control"

Go Anywhere! Sit Anyplace! New patented "DRI-GUARD" liners have abundant absorbent material where most needed! Launderable or disposable liners enclosed in soft vinyl holder prevent escape of any moisture. Use 2 launderable liners at once for full night's sleep without change. Guaranteed effective for both men and women or money back. **ORDER BY WAIST SIZE.** Complete with launderable liner, \$8.95; Extra liner \$3.50, 2/\$6.75; 48 disposable liners \$7.95. (add 75c postage/handling, 6% tax in Calif.).

RALCO MFG. CO., Dept. 638
1537 E. McFadden, Santa Ana, CA 92705
(Sold by Mail Since 1965)



50 YARDS LACE \$1.45

LACE — LACE — LACE . . . 50 yards of LACE
In delightful patterns. Edgings, insertions, etc. Assorted beautiful designs, colors and widths. Pieces at least 10 yards in length—none smaller. Marvelous for dresses, pillow cases, etc. Terrific as hem facing on new double knit fabrics. **Only \$1.45 plus 30c pstg., double order \$2.79 plus 50c pstg. Satisfaction guaranteed!**

FREE with lace 50 BUTTONS!
50 New, High Quality Buttons. Assorted colors, sizes and shapes. Sent FREE with each lace order. Please allow up to 6 weeks for delivery.
LACE LADY
808 Washington

DEPT. LN-668
St. Louis, Mo. 63101

THE UNIQUE
Instant Spell'er



FASTER AND HANDIER THAN ANY DICTIONARY

6,000 MOST COMMONLY MISPELLED WORDS ARE CORRECTLY SPELLED, DIVIDED AND ACCENTED.

Instant Speller

An aide to business and professionals, students, secretaries. Puts a world of words right at your fingertips. Works on touch method. Press down release tab with pointer on first letter of word wanted. In a flash find your answer. No pages to turn. For every home, every office, this side of genius. A perfect gift.

30-DAY MONEY BACK GUARANTEE.

Only **\$4.99** plus 80¢ shipping & handling (Calif. add 6% tax)

● **SAVE 2 for \$8.99**, plus \$1 shipping & handling.

Instant Speller Co., Dept. E117

125 So. Western Ave. Los Angeles, Calif. 90004

L.L.Bean
Outdoor Sporting Specialties

Chamois Cloth Shirt

For Men and Women

Sueded cotton. Looks and feels like high grade chamois leather. Machine washable and is more durable than wool. Mr. Bean personally used this shirt on his hunting and fishing trips. Colors: Navy Blue. Tan. Bright Red. Forest Green.

Women's sizes: 10 to 20. Men's sizes: 14½ to 20. Men's Long Model, sizes 15 to 19.



Please send FREE 128-page Fall 1977 Catalog. Please Ship Postpaid

Ladies' Chamois Cloth Shirts @ 12.50 ppd. Size _____ Color _____

Men's Chamois Cloth Shirts @ 13.00 ppd. Size _____ Color _____

Men's Long Chamois Cloth Shirts @ 14.00 ppd. Size _____ Color _____

Check Enclosed Master Charge
 BankAmericard American Express

Card Number _____ Expiration Date _____

Name _____

Address _____

City _____

State _____ Zip _____

L.L. Bean, Inc.

7171 Cedar St., Freeport, Maine 04033

DO-IT-YOURSELF

FINE GRANDFATHER CLOCK KITS STARTING UNDER

\$200

(including West German movement)

- Heirloom quality
- Solid ¾" hardwoods: black walnut, cherry, mahogany, oak
- Easy to assemble, parts pre-cut
- Solid brass West German chiming movements
- Money back guarantee
- Factory direct prices
- Prompt shipment

MASTER CHARGE and BANKAMERICARD/VISA ACCEPTED

Write for FREE color catalog



EMPEROR® CLOCK COMPANY

WORLD'S LARGEST MANUFACTURER OF GRANDFATHER CLOCKS
Dept. 303, Emperor Industrial Park
Fairhope, Alabama 36532

WARM-UP JACKETS and T-SHIRTS

IMPRINTED WITH ELKS EMBLEM and LODGE NO.

FLANNEL OR PILE LINED JACKET

Men's water repellent nylon jacket with flannel or heavy pile lining. Slash pockets, snap front. Blue with gold Elks emblem.

T-SHIRTS: High quality. Gold with blue emblem.

PERSONALIZED SPORTSWEAR

1510 Fairfield, Ft. Wayne, Ind. 46802
Please send jacket(s) and T-shirt(s) specified. Print quantities and lodge no. in proper block. Ind. res. add 4% tax. No CODs. Add \$1 extra per garment for lodge no. (optional).

	S	M	L	XL	each	TOTALS
Jacket, lined					15.95	\$
Jacket, pile					18.95	
T-Shirt, Gold					4.95	
Lodge number ... optional					1.00	

I enclose in full \$ _____

Name _____

Street _____

City _____

State _____

Zip _____

Elks Family Shopper

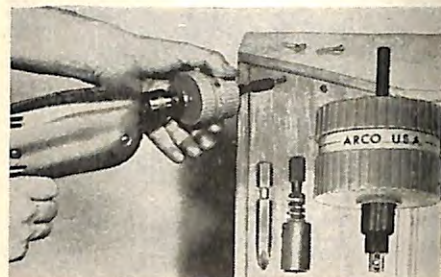

ARCO REVERSIBLE SPEED REDUCER & SCREWDRIVER drives, removes screws, nuts, bolts. Increases drill power 11 times, goes forward & reverse. Fits any electric drill. No. 780M, \$10.95 ppd. incl. Flat Bit with holder for #6-14 screws, #2 Phillips Bit & Socket Wrench Holder. Arco Prod. Corp., Dept. EL-11P, 110 W. Sheffield Ave., Englewood, N.J. 07631.



STARLIGHT SETTING FOR TITANIA beautifully complements this dazzling man-made jewel—only \$15.00 per carat and more brilliant than a diamond. A one-carat Titania in 14-Kt. gold setting, \$59.00. May be cut to fit your jewelry. Write for free ring size chart, catalog. Regent Lapidary Co., Dept. EKP-11, 2816 Morris Ave., Union, N.J. 07083.

NEW \$19.95 BADGE-A-MINIT™. CAN MAKE YOU \$25 TO \$100 PER HOUR



Now, at half of the previous cost, you can make colorful, plastic-protected, metal pin-back badges instantly! Make them when and where you need them to make BIG profits taking orders for slogan buttons or photo mirrors that you sell for up to \$2.50 each. Parts cost you just pennies! For more information and your FREE SAMPLE BUTTON write to BADGE-A-MINIT, Ltd., Dept. EL-117, Box 618, La Salle, Ill. 61301. Or send \$19.95 (plus \$1.75 shipping and 5% sales tax for Ill. residents) for the system, including hand die press, color coded dies, one dozen badge parts and illustrated details and instructions. MONEY BACK GUARANTEE!

GENUINE BLACK ONYX



Beautifully Engraved

ELKS EMBLEM RING. Handsome onyx ring bears the Elks emblem and is elegantly engraved with two initials. 10 K. Gold-filled and a great gift for Elks. Send ring size (6 to 13) and be sure to specify initials. A good buy at only \$29.95 ppd. Gift boxed.

STADRI, 147-47 6th Ave., E, Whitestone, N.Y. 11357

Elks Family Shopper



A PURR-FECT PRESENT! The Contented Cat curls up so nicely on a table, a shelf, the mantel or among your plants, or on the hearth. A very pleasant pet because it is made of wood, handcrafted and stained in glowing natural oak finish. 6"x6½"x3". \$6.95 plus \$1.25 shpg. Order from Postamatic Company, Dept. E11, Lafayette Hill, Pa. 19444.

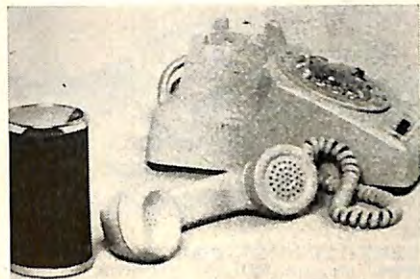

PHONE AMPLIFIER HAS NO WIRES. Place phone receiver by loudspeaker-amplifier and you can hear the caller's voice across room; talk back from anywhere in room. No wires, no connections; frees both hands. Operates on 9-V transistor battery. \$19.95 plus \$1.50 shpg. J. W. Holst, Inc., Dept. EK-117, 1864 E. US-23, East Tawas, Mich. 48730.



DELUXE FOLDING SCISSORS \$1

An open and shut case of convenience. Quality steel blades, cushioned plastic handles, ingeniously engineered to fold to absolutely safe 3" size to slip easily into pocket, purse, sewing kit, first aid kit, glove compartment, tackle box, etc. Great for in-store coupon clipping. Vinyl case included. A great value at only \$1 Pr., 2 Pr. \$1.79, 6 Pr. \$4.75, 1 Dz. \$8.75 ppd. Fund Raisers write for quantity prices. Money back guarantee. Pls. allow up to 6 wks. for delivery.

TWO BROTHERS, INC., Dept. FS-290
808 Washington St. Louis, Mo. 63101

32-PAGE CATALOG



doggie SNOW SUIT

TAMES WINTER WEATHER!

Keeps doggie toasty warm on icy, windy days! Made of gay, red orlon pile, it has knitted, adjustable cuffs and a detachable hood. There's a full-length zipper down the back for easy-on, easy-off! For proper fit, measure pet from base of tail to collar. Satisfaction assured!

SIZES: 10, 12, 14, 16—\$12.95

SIZES: 18, 20—\$13.95 (Add 75c postage)

CATALOG! Latest things for pup and kitty. Exciting pet accessories! Only 25¢ or free with order.

Dpt. 2182, Box 8850, Metairie, LA 70011



My Feet Were Killing Me...Until I Discovered the Miracle of Hamburg!

It was the European trip I had always dreamed about. I had the time and money to go where I wanted—see what I wanted. But I soon learned that money and time don't mean much when your feet hurt too much to walk. After a few days of sightseeing my feet were killing me.

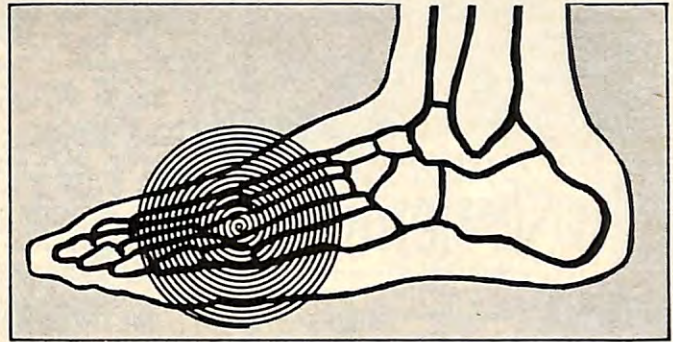

Oh, I tried to keep going. In Paris I limped through Notre Dame and along the Champs-Élysées. And I went up in the Eiffel Tower although I can't honestly say I remember the view. My feet were so tired and sore my whole body ached. While everybody else was having a great time, I was in my hotel room. I didn't even feel like sitting in a sidewalk cafe.

The whole trip was like that until I got to Hamburg, Germany. There, by accident, I happened to hear about an *exciting breakthrough for anyone who suffers from sore, aching feet and legs.*

This wonderful invention was a custom-made foot support called Flexible Featherspring. When I got a pair and slipped them into my shoes *my pain disappeared almost instantly.* The flexible shock absorbing support they gave my feet was like cradling them on a cushion of air. I could walk, stand, even run. The relief was truly a miracle.

And just one pair was all I needed. I learned that women also can wear them—even with sandals and open backed shoes. They're completely invisible.

Imagine how dumbfounded I was to discover that these miraculous devices were sold only in Europe. Right then I determined that I would share the miracle I discovered in Hamburg with my own countrymen.

Today thousands of Americans of all ages—many with foot problems *far more severe* than mine—have experienced this blessed relief for themselves.

Here's why Feathersprings work for them and *why they can work for you.* These supports are like nothing you've ever seen before. They are custom fitted and made for *your feet alone!* Unlike conventional devices, they actually imitate the youthful elastic support that Nature originally intended your feet to have.

Whatever your problem—corns, calluses, pain in the balls of your feet, burning nerve ends, painful ankles, old injuries, backaches or just generally sore, aching feet. Flexible Feathersprings will bring you guaranteed relief with every step you take.

Don't suffer pain and discomfort needlessly. If your feet hurt, the miracle of Hamburg can help you. Write for more detailed information. There is no obligation whatsoever. Just fill out the coupon below and mail it today.

© Featherspring International Corp. 1976

FEATHERSPRING INTERNATIONAL CORPORATION
514 N. E. 124th, Dept. E117
Seattle, Washington 98125

YES! I want to learn more about the guaranteed relief Flexible Featherspring Foot Supports can give. Please send me your free brochure. I understand that there is no obligation and that no salesman will call.

Print Name _____

Address _____

City _____

State _____

Zip _____

3 REAL OLD COINS

INDIAN HEAD CENT
LIBERTY "V" NICKEL
MERCURY DIME



All Three Only \$3.00

Only \$3.00 brings you an Indian Head Cent minted before 1909, a Liberty "V" Nickel minted before 1913 and a Mercury Dime before 1946.

1909-VDB

FIRST LINCOLN PENNY \$3.50

Designer Victor D. Brenner's initials appear on the back of the coin.

SAVE 50¢ ALL ABOVE COINS ONLY \$6.00

Please add 50¢ postage. Immediate shipment.

Catalog included. Satisfaction guaranteed.

Village Coin Shop

Dept. E, Plaistow, N.H. 03865

PAUL REVERE BOWLS



These beautiful silver-plated bowls are reproductions of the famous bowl made by Paul Revere in 1768. Use them to serve candy and nuts and proudly display them on your shelf or mantel. Each bowl sold separately.

4" PAUL REVERE BOWL \$ 9.95

5" PAUL REVERE BOWL 12.95

6" PAUL REVERE BOWL 14.95

Add \$1.00 shpd. Order today from

ROCKWOOD HOUSE

Dept. EL-117, 8 Rockwood Ave., Trenton, NJ 08619

NEW GIFT ITEM & BAR ACCESSORY



cocktail lovers, attention!

Twist-O lemon

choicest blends of imported and domestic lemon oils (not lemon juice)

Just a whisk of Twist-O lemon across the top of your cocktail gives it that gourmet touch. It's so easy—just a squeeze of the atomizer! Each bottle puts perfection in approximately 2800 cocktails! Eliminates peeling lemons. Always on hand. Handsome bottle on your bar instantly tells your guests that you know how to make a perfect cocktail. Twist-O lemon is smartly gift-packaged. Ideal Present. Send Check or M.O. for \$6.95.

Pstg., hdg. 75¢ ea., 20¢ each extra box. Refill \$5.95. Ill. res. add 4% sales tax. **REVORD-JAMES & CO., Golf, Illinois 60029**

LEADING DECORATORS STRONGLY RECOMMEND OUR STATUARY COLLECTION TO DECORATE YOUR HOME



SCHNAUZER 19" High \$24.50
SMALL OWL 15" High \$13.00
TIGER CUB 16" High \$19.50

Now you can order these and many more of our exciting and carefully crafted lacquered cold-cast sculptures, direct from our factory at very low prices. Decorate with this colorful and unique collection to intensify the beauty and elegance of that special spot in your home or office. This charming collection makes the best gift ideas for any occasion. When ordering, please add \$2.50 for shipping and handling charges for each item purchased. Write for **FREE Color Catalog.**

Satisfaction guaranteed or money back.

METROPOLITAN STATUARY

21 Dunham Pl., Studio 101-A, Brooklyn, N.Y. 11211

1920's COUNTRY CORN POPPER



Now available, the old-time corn popper everyone has been looking for. The same grandma used over 50 years ago. Authentic reproduction with blued steel welded construction. Its seamless bottom and rotary agitator insures maximum, just right, popping. 3 quart capacity. Easiest to use for best results ever. Use on gas, electric or wood stoves. \$9.98 each, plus \$1.50 shipping. 2 for \$19.00, plus \$1.50 shipping. Order from: **K. Miller Specialties, Dept. EK-117, P.O. Box 186, Verona, NJ 07044.** New Jersey residents add 5% sales tax. Satisfaction guaranteed.

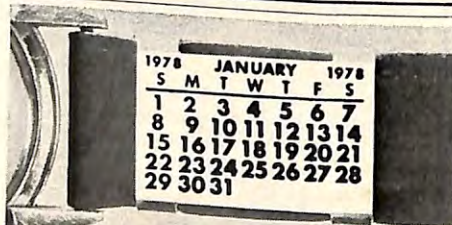

METAL WATCHBAND CALENDARS

Used all day, every day. Best made in U.S. Easy to read, large bold print. Fits quickly on all men's watchbands. Silver calendar one side, gold on other. Sundays, Holidays in red. 100% metal. 12 separate calendars. 1 year supply in gift wallet. Start any month (specify starting month). 1 set \$1.95 ppd; 3 sets \$5.35, 5 sets \$8.35; 10 sets \$15.00. Calif. res. add 6% tax. Great gift or stocking stuffer. Immed. delivery guar.

3941 Alamo **McSPI, Dept. 61** Riverside, Calif. 92501

Fast, Efficient, Reliable COMPOST BINS

Turn garden and kitchen wastes into rich, fertile compost to improve poor soil and feed your plants. Grow bountiful harvests of vegetables and more beautiful flowers. Scientifically designed bins produce valuable compost in weeks. No turning the heap. Make a ton in one season. Send for **FREE catalog:**



ROTCROP 55 Buttonwood Street New Hope, PA 18938

THE ELKS MAGAZINE NOVEMBER 1977

Elks Family Shopper



SHOES FOR SALE! Richard King, V. P. of Hanover Shoe, Inc., offers over 200 styles of shoes and boots at wholesale prices. Save your friends \$15 to \$20 per pair, make a spare time income up to \$300 a month for yourself. Also free shoes for you. Send for free kit and catalog. Hanover Shoe, Dept. 1921, 111 N. Forney Ave., Hanover, Pa. 17331.



PERFECT GIFT FOR SHRIMP LOVERS. Original Zipout Shrimptool peels and deveins shrimp in one quick thrust. Cuts cooking time, allows shrimp to enlarge, absorb seasoning fully, curl beautifully, be juicier, more delicious. Cooking odors eliminated! U.S.-made. \$1.98 ea. ppd., \$18 per doz. ppd. Zipout, Intl., Box 1972, Cedar Rapids, Ia. 52406.

BRAIN PUZZLER'S DELIGHT

By E. R. Emmet

A treasury of unique mind-stretching puzzles that can be solved by straight logical thinking and reasoning. No specialized math. Offers the pleasures of discovering solutions through use of ingenuity, imagination, insight, and logic. Stimulates and refreshes the mind. Fascinating, entertaining puzzles, arranged in order of difficulty, with (some amazing!) solutions and full explanations at end of book. **ILLUSTRATED ORDER.**

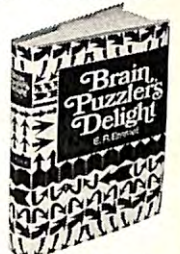

NOW! \$7.95 plus 60¢ handling. 10-Day Money Back Guarantee.

EMERSON BOOKS, Inc., Dept. 229-D Buchanan, N.Y. 10511

ADJUSTABLE T.V. POLES

Hold your portable T.V. right where you want it, without awkward tables or stands. Takes any width, up to 14" deep, 17" high. Brass tone finish pole has spring tension rod to adjust to 7 1/2 to 8 1/2 ft. ceiling heights. Can be set up in Hi or Low position. Hi position is great for reclining watchers! Made in U.S.A. Extension for higher ceiling, add \$2.00.



Prompt Shipment
\$13.99 Plus \$1.00 postage
 Write for **FREE catalog**
Holiday Gifts
 Dept. 711-7A
 Wheat Ridge, Colorado 80036

TWIST-N-HOOK



Corrosion Resistant Type 316 Stainless Steel

ASSEMBLED UNIT With Thimbles

\$19.95

Hooks only (each) \$6.95
 Actual size 7" long, 1/4" dia. Check or money order. Add \$1 handling. Wn. Res. 5.1% tax. Allow 3 weeks delivery.

MAIL TO:
W. M. DIBBLE & SON
 Rt. 1, Box 345-I
 Olympia, Wash. 98502
 (206) 866-1665

Send for Brochure
A GIFT

BEAUTIFUL AMERICA \$3.95

Appointment Calendar Opens to 17"x11 1/2"

13 gorgeous 4-color scenes of the U.S.A. This calendar has large blocks for memos.



Spiral bound. Lies flat, hangs on wall or fits briefcase. Spectacular color photos. Send \$3.95 & 50¢ Pstg&Hdg (money back guarantee) to: **SORMANI, Box 403E, Greenwich, 06830.** FREE Catalog of 200 Imported Calendars available on request.

Elks Family Shopper



THE WHOLE FAMILY CAN PLAY PYRAMID CHECKERS. Seven action-packed games, beginner to advanced levels, can be played by 1, 2, 3 or 4 players. Full set of rules, sturdy styrene pyramid playing board, 30 playing pieces included. \$9.95 ppd. Ruffin Enterprises, Dept. H9, 4805 Jefferson NE, Albuquerque, NM, 87109



YOU CAN PLAY THE GUITAR IN 7 DAYS by following Ed Sale's 66-page Secret System. You play a song the first day, any song in 7 days. Includes 52 photos, 87 chord and finger-placing charts, 110 songs, Chord Finder, Special Guitarists' Book of Knowledge, tuning device. \$3.98 plus \$1.00 shpg. Ed Sale, Studio EL11, Grand Island, Fla. 32735.

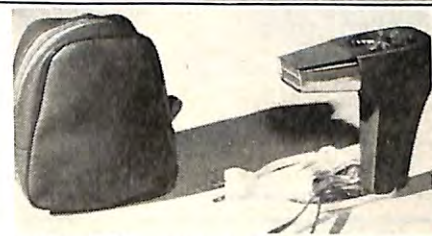

ELECTRIC MINI HAIR DRYER, designed for people on the go, travels with you to dry your hair after shower or swim. Just 4"x4", it has plenty of heat and air power. Comes in attractive travel case that fits easily in luggage. \$8.95; 2 for \$15. Add 70¢ shpg. (Ill. res. add 5% tax.) Chorley House, Dept. ER, P. O. Box 117, Wilmette, Ill. 60091.

PSORIASIS TREATMENT SUIT

ELIMINATES WRAPPING IN PLASTIC

Lightweight, non-toxic Vinyl two-piece suit. Elastic at all openings seals in body heat to make medication penetrate deeper. Eliminates wrapping in plastic . . . Eliminates staining clothes and sheets. Used at Duke University Hospital, many others. Washable. Lasts for months. At Your Druggist Or Order Direct. Specify man or woman, give height and waist size. \$6.95 plus \$1.00 postage . . . Stim-Ez Suit Co. 157 6th Ave. N.E., Dept. EK-11, St. Petersburg, Fla. 33701.



Own this
GENUINE GOLD PIECE
at an unbelievably low price!



Actual size:
Same as U.S. Quarter
15/16" diameter

1977 Gold Christmas Medallion

Now you can own a genuine 10 karat gold Christmas medallion . . . at an unbelievably low price!!! Commemorates world peace in five languages. This rare gold piece is truly a collectors' item. Only 40,000 minted in the entire world before the dies are destroyed! Therefore, we must limit orders to 3 per person. The 1977 Gold Christmas Medallion is struck in a mirror-like finish. Also available mounted in a gold-colored pendant with 24-inch chain (shown below). This unique gold piece can be yours in a beautiful presentation case or fashionable pendant necklace designed for men and women. Think of it . . . the perfect gift for family and friends! Truly a cherished keepsake for many years. Quantity is limited! Order yours now!!!



Genuine Gold Medallion mounted in beautiful gold-colored pendant with 24-inch chain. Fine gift for men and women.

- 10K Gold... not "gold filled" or "gold plated."
- Limited edition — only 40,000 minted.
- Available with optional pendant and 24-inch chain.
- Includes serial numbered certificate of authenticity.
- 30-day Money Back Guarantee.

ONLY
\$19.95

GENUINE GOLD MEDALLION
Limit: 3 per person
or \$24.95 mounted in pendant

Note: Due to fluctuation in price of gold, we reserve the right to withdraw this offer at any time.

AMERICAN COIN COMPANY, INC. • 12164 Ventura Blvd. • Studio City, CA 91604 • (213) 980-8845

American Coin Company, Inc.
12164 Ventura Blvd. • Studio City, Calif. 91604 Dept. 7

Enclosed please find \$ _____ in payment for:

- _____ gold pieces @ \$19.95, plus \$1.00 ea. postage and handling (Limit: 3 per person). (CAT. =101)
- _____ gold pieces mounted in pendant with 24-inch chain @ \$24.95, plus \$1.00 ea. postage and handling (Limit: 3 per person). (CAT. =102)

NAME _____

ADDRESS _____

CITY _____ STATE _____ ZIP _____

California residents must add 6% sales tax.

Or charge this order on any of the following credit cards:

- Visa (BankAmericard)
 Mastercharge
 American Express
 Diners
 Carte Blanche

Account No. _____

Expiration Date _____

SUPER STRIPPER

Powers Paint Off

**FASTER, CLEANER
EASIER, than any
other way!**

- Furniture
- Wrought Iron, Masonry
- Autos and Boats
- Hundreds more big and little jobs

Never buy expensive, paint removers again. Caustic chemical removers are dangerous to skin and eyes and highly flammable. Works on a new principle to do the job cheaper, safer and last a lifetime. Made of solid steel, not cheap plastic! High-speed "whipping action" makes paint, rust and scale vanish as if by magic!

**FITS ANY
1/4" DRILL
CASE-HARDENED
STEEL (NOT
CHEAP PLASTIC.)**

**SAFE TO FINE
FURNITURE** when used as directed. Leaves a satin smooth finish, ready for paint or stain. No sanding needed (won't raise wood grain as liquids do).

BOATS, HOUSE SIDING, does all big jobs in a fraction of the time.

STOPS RUST DEAD, strips rusted spots down to the bare metal fast! Cleans masonry and swimming pools effortlessly.

FULLY WARRANTED

Made in America
Full instructions included.

SUPER VALUE only \$12.95

CREDIT CARD CUSTOMERS CALL TOLL-FREE (800-243-5592)

SUPER STRIPPER (Dept. RS-114)

49 Riverside Ave., Westport, CT 06880

Please rush... SUPER STRIPPER(S) @ \$12.95 ea., two for only \$23.95. Add \$1 handling for each. Sorry, no CODs

Order: COARSE for big jobs FINE for furniture

Enclosed is \$..... Interbank #.....

CHARGE: Diner's Club BankAmericard/Visa
 Master Charge Carte Blanche
 American Express

Acc't. #..... Exp. Date.....

PRINT NAME.....

ADDRESS.....

CITY..... STATE..... ZIP.....

(Please add applicable sales tax.)

BELT VALET

The indispensable hang-up for belts. It holds up to 24 in easy-to-see, easy-to-get order on closet rod or door. 4 strong brass hooks on handsome walnut stained wood. 8 x 5 1/2 x 3/4", \$6.95 + \$1 post. Two for \$13.50 + \$1.15 post.

Quality Gift Catalog, 25c

SLEEPY HOLLOW GIFTS

6651 Arlington Blvd., E11-7, Falls Church, Va. 22042

Unique COIN COUNTER & PACKAGER

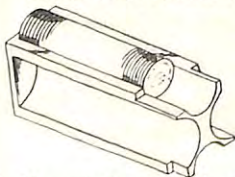

\$2.50

plus .35 (p-H)
Pa. residents add 6% sales tax

Enables you to accurately count pennies, nickels, dimes and quarters in standard amounts and easily place them into standard tubular coin wrappers. Plastic and pocket-size. Dealer inquiries invited.

CHESSMAN CORP., Dept. E
296 Wyoming Ave., Wyoming, Pa. 18644

WIND DIRECTION AT A GLANCE

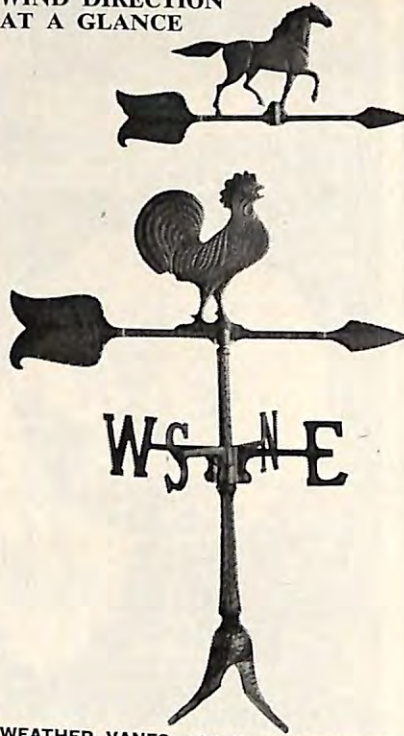

WEATHER VANES add the finishing touch to your country home! Perfect for your garage, farm or ranch too. Ornamental as well as useful. Precise wind direction at a glance. Balanced arrow responds to slightest breeze! These fine quality Weather Vanes are carefully handcast in aluminum and finished in satin black. Free from maintenance and rust proof to withstand decades of exposure. Complete with adjustable mounting base that will fit any pitched roof, horizontal or vertical surface. (Cupola base also available, specify) Arrow 18" long. Support 24" high. Great gifts.

Crowing Rooster \$14.95 + \$2.00 pp.
Galloping Horse \$14.95 + \$2.00 pp.

SAVE two for \$29.90 plus \$2.00 shipping.

Send check or M.O. 15 day money back guarantee

J. W. HOLST, Inc. Dept. EV-117, 1864 E. US-23
East Tawas, Mich. 48730



"SAVE YOUR HEART"

with a **STAIR-GLIDE®** Stairway Elevator

RENTAL-PURCHASE Program Available

Your STAIR-GLIDE® installs easily and in less than 2 hours. No marring walls or stairway. No special wiring required. Shipped directly from factory within 4 days. STAIR-GLIDE®... the nation's largest selling stairway elevator! UL LISTED.

USED BY THOUSANDS: CARDIAC PATIENTS, ARTHRITIS, SENIOR CITIZENS, PHYSICALLY RESTRICTED, POST OPERATIVES...and household convenience.

WRITE FOR FREE BROCHURE AND NAME OF DEALER NEAREST YOU.

AMERICAN STAIR-GLIDE® CORP.

4001 East 138TH ST., Dept. E-117
Grandview, Missouri 64030

Elks Family Shopper

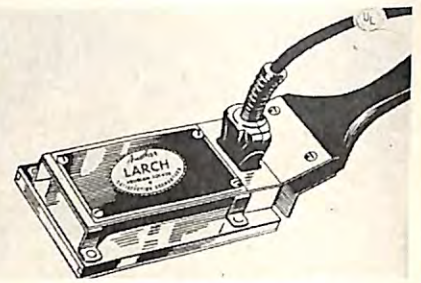

PROFESSIONAL TYPE ELECTRIC PAINT & WALLPAPER REMOVER strips off up to 12 layers of old paint down to bare wood grain. Leaves surface clean, smooth. Use indoors or out on flat, curved, or irregular surfaces. Works on house current. \$15.98 plus \$1.50 shpg. Larch, Dept. E-11, Box 770, Times Sq. Sta., N.Y. 10036.



GAMES FOR MATH BUFFS and those who love numerical puzzles. "The Math Entertainer" is a treasure trove of teasers, ticklers, mathematical traps and twisters by the hundreds to amuse, bewilder and, not incidentally, instruct. Answers and complete explanations for all problems. \$5.95 plus 60¢ shpg. Emerson Books Inc., Dept. E-11, Buchanan, N. Y. 10511.

SENSATIONAL BLADE SHARPENER for ROTARY SHAVERS

Now, keep your floating head Norelco or other make rotary shaver at peak efficiency. This special new sharpener is the perfect, easy way to give rotary blades the sharpest possible cutting edge. Just use it for one minute, just once a month for smoother, faster, cleaner shaves. Order yours today, it really works! Send check or money order to

\$3.99

Plus 26¢ Pstg.

BARCLAY, Dept. 51-MB 1575 North Dixie Hwy., Pompano Beach, Florida 33060



New Way to Sleep!



Tee-PJ's resemble a T-shirt, but are over a foot longer. Rib-Knit, soft combed cotton. Gives when you move, eases up when you relax. No bind, no bunch, no chafe, no buttons, no ironing! If not most comfortable sleeper you've ever worn, return within 7 days for full refund and we send you regular T-shirt FREE!

S (34), M (36-38), L (40-42), XL (44-46, for weight over 180 lbs. and/or over 6 ft.)

\$7.00 ea. 3 for \$16.00
NOW! Tee-PJ's available in long sleeves with knit wristlets.

\$9.00 each 3 for \$22.00

Choose Snow White or Soft Blue

WITTMANN TEXTILES
6787 Southboro St., Dept. 220
West Palm Beach, Florida 33408

SANTA AND HIS REINDEER 'DANCE' ACROSS YOUR ROOF OR YARD THIS CHRISTMAS



A FULL 10 FEET LONG

Here's a marvelous outdoor display for your home this Christmas. This molded plastic Santa with eight reindeer is a full 10 feet across and 2 feet wide! Bulbs and reflectors illuminate it brightly. Comes with U.L. approved outdoor cord. Stakes provided to anchor it to ground or house. Use it out in the yard, on the porch, or even prancing across your roof. A delightful Christmas Holiday decoration!

No. 9038—Lighted Santa and Reindeer\$11.95

**ELECTRIC ...
Each House
Actually Lights Up!**

**Bring The Warmth Of
Christmas To Your Home!**



**'10' PIECE BAVARIAN
CHRISTMAS VILLAGE**

The roofs are speckled with fresh winter snow...but when it's plugged in — a warm light beckons from each friendly window. Our Little Barvarian Village is so perfectly detailed... even the steepled church comes aglow with the rich colors of stained glass windows! What a holiday touch for the foot of your tree... or imagine it nestled between the branches. Use it as a window display — makes a wonderful Christmas centerpiece too. This quaint little village wishes all who see it... "A Very, Merry Christmas"!

No. 9117—10-piece Electric Barvarian Village\$6.95
SPECIAL, SAVE! 2 for 12.00

**Black Forest
Weather House**

*Tells you the weather
every morn and eve!*

**Makes a Charming
Christmas Gift!**

\$3.98



**WATCH
THE GO-GO
ACTION!**

**100%
Hand
Made**

For nearly two centuries, generations of gifted woodcraftsmen from the mountainous Black Forest region of West Germany made these delightful *Wetterhauschen*. Each is meticulously hand-made with methodical German precision. This original Weather House is an authentic miniature. When papa Hans strides out with his diminutive umbrella, watch for rain or

snow! But when Brunhild goes for a stroll, be of good cheer for clear, dry weather and sunny skies are ahead!

No. 4149—Weatherhouse3.98
(2 for 7.00) (3 for 9.00)

The Authentic Black Forest
Cuckoo Clock



Now
Only
14.99

**WITH
ACTION
PENDULUM**

You'll be delighted with the charming little Cuckoo that clearly calls the time each quarter hour... the slowly swinging pendulum... the rich colors of this hand made masterpiece... the accuracy and dependability of the fine clock movement... all so meticulously put together and carefully hand painted. The Cuckoo Clock is a BIG 12½ inches tall from the hand-carved top to the pendulum.

A MARVEL OF THE CLOCKMAKER'S ART!
For centuries, generations of gifted woodcraftsmen from the mountainous Black Forest region of West Germany have made these delightful Cuckoo Clocks. These world famous clocks have often been imitated but never equalled! This ancient woodcraft and clock-making art, jealously guarded, has been passed from father to son down through the years. Each Cuckoo Clock is meticulously hand made with methodical German precision — every one fashioned with the rich sepia woods and fine quality materials of the Black Forest.

No. 4395—Black Forest Cuckoo Clock.. \$14.99

Foster-Trent INC.
2345 Post Road, Dept. 512-M, Larchmont, N.Y. 10538
Please RUSH guaranteed articles as specified below. I enclose payment with this condition: I must be completely satisfied or I may return within 7 days for my money back at once.
Please enclose 95¢ with order to cover shipping cost. (N.Y. State residents add appropriate sales tax.)

HOW MANY	ITEM NO.	DESCRIPTION OF ITEM	PRICE
		Shipping & Handling	.95
		N. Y. State residents please add appropriate sales tax*	
		Please send check or money order. Sorry, no C.O.D.s	Total

Name _____ Apt. # _____
Address _____ City _____
State _____ Zip Code _____

© 1977 Foster-Trent

FINISH CORNERS • CUT MOULDING WITH ANY ELECTRIC DRILL NO \$50 ROUTER OR \$6 BITS NEEDED!

You don't have to buy an expensive Router to finish corners, moulding & trim. "ARCO" Cutters do the work at a fraction of the cost. Simply slip the Cutter's 1/4" shank in any drill and it's ready to produce! Dual Guides assure accurate cuts along entire length & width of workpiece. Cuts wood, plastics, soft metals. Quality-made in U.S.A. of hardened steel. These Cutters also fit & work with all Electric Routers.

No. 6—3 PIECE CUTTER SET

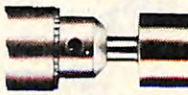

\$625

FANCY COVE-CUTTER

CUTS 3/4" CONTOURS



ROMAN OGEE-CUTTER



RABBET-CUTTER

No. 3—3 PIECE CUTTER SET

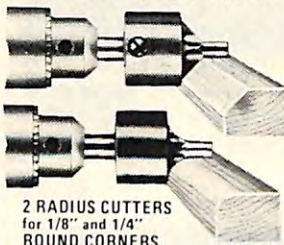

\$655

2 RADIUS CUTTERS for 1/8" and 1/4" ROUND CORNERS

ADJUSTABLE BEVEL-CUTTER cuts 45° bevels from 1/32" to 5/16" wide

No. 7—3 PIECE CUTTER SET

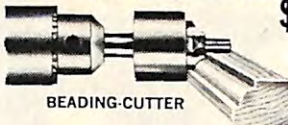

\$625

BEADING-CUTTER

CUTS 3/4" CONTOURS



COVE-CUTTER



OGEE-CUTTER

MAIL THIS COUPON TODAY!

ARCO PRODUCTS CORP., Dept. EL-11,
110 West Sheffield Ave., Englewood, N.J. 07631

Ship at once on your 30-day Money Back Guarantee:

- No. 3, 3-PIECE CUTTER SET \$ 6.55
- No. 6, 3-PIECE CUTTER SET 6.25
- No. 7, 3-PIECE CUTTER SET 6.25
- No. 6703, ALL OF ABOVE 9 CUTTERS 15.95

I enclose Check, M.O.—SHIP POSTPAID.
(No C.O.D.'s)

Name.....

Address.....

City..... State..... Zip.....

SPECIAL SAVING!

Order all of above 3 Sets at our Special Money-Saving Price. No. 6703, total of 9 Cutters, only.....

\$1595

These & over 300 other ARCO Tools available at Hardware Depts. everywhere, or order direct on 30-day Money Back Guarantee.

PROFESSIONAL DENTURE CLEANER Cleans Safely, completely With Sonic Vibrations

Your dentures, plates and bridges will be as clean and perfect as new!! No more overnight soaking—the DENT-U-SONIC removes tartar, stains, film, bacteria and food particles by chemical action and sonic vibration—in only 5 minutes!! You get the complete electronic DENT-U-SONIC unit, ready to plug into household current, and a 5 oz. bottle of Denture Cleanser which can be used over and over again. All for only \$14.95. Re-order forms for additional bottles of Denture Cleanser at \$2 will be sent with your unit. At this new low price, you can own your own Professional DENT-U-SONIC. No more taking your dentures to the dentist every six months to be cleaned. Manufacturers Warranty.

TWO WEEK RETURN PRIVILEGE

Call Toll Free 800-243-5676 (Conn. res. call 1-800-882-6500)

Please rush _____ DENT-U-SONIC UNIT(S) @ \$14.95 (plus \$2 ship & insur)

- Check or MO enclosed (Fla. res. add 4%)
- Charge Master Charge, BankAmericard(Visa), American Express, Diners Club or Carte Blanche

Card # _____ Exp _____

Name _____

Address _____

City _____ State _____ Zip _____

Signature _____

5 Minutes A Day in DENT-U-SONIC will keep your dentures sparkling, fresh and clean.

New Low Price \$14.95



Gemstance Gallery 1343 Main Street, Sarasota, Fla. 33577 813-366-1951

Elks Family Shopper



HOLD-IT-ALL TELEPHONE STAND holds your phone and all accessories. And it's a decorative table too. 3 wood-grain shelves hold directories, books, etc. Ends are brass-finished and have rubber-tipped legs. Only 26" high x 12" wide x 9 1/4" deep, it takes up little room. \$14.99 plus \$1.00 shpg. Hanover House, Dept. Z3561, Hanover, Pa. 17331.



RAILROAD WATCH brings back memories of the conductor checking his watch. Bold, easy-to-read numbers with large hour hands. Back plate has an embossed locomotive design. Gleaming gold-tone 2" dia. case. 12 1/2" heavy link fob chain. \$16.99 plus \$1.00 shpg. J. W. Holst, Inc., Dept. EK-117, 1864 E. US-23, East Tawas, Mich. 48730

A MUST FOR YOUR CAR



Now available, official ELK vanity plate. This plate is of the highest quality. .032 gauge aluminum white reflectorized background for safety. Handsome logo and embossed border in black. Standard size 6"x12" with bolt holes. 1 year guarantee. Send \$5.35 plus \$5.00 for postage and handling. (Mass. residents add 5% sales tax) to: AMERICAN VANITY PLATE COMPANY, Box 30 WINCHESTER, MA 01890. Allow 6-8 weeks for delivery.

GOOD KNIVES DESERVE

A GOOD HOME only \$19.95 ppd.



Gourmet Knife Block

gives your knives the special treatment they deserve. Natural hardwood-sanded to perfection—velvet touch end-grain butcher block has slots for seven knives and a steel. 10 1/2"x5"x5"—knives not included. Washington res. add 5.3% tax. Alaska and Hawaii res. add \$1.00 handling. Send check or money order for \$19.95 to:

GOURMET SELLARS

1418 Bellevue Ave. Seattle, Wash. 98122



CUSTOM BILLIARD CUE & CASE

Adjustable weight and length, nylon wrap with inlaid handle. Hard Box Case—red velvet foam rubber interior with separator. Includes tip shaper, 2 cubes chalk, 3 spare tips.

Complete Package \$14.95
Postage & Handling 2.00
\$16.95

ROBERTSON BILLIARD SUPPLIES

1721 N. Franklin Street, Tampa, Florida 33602

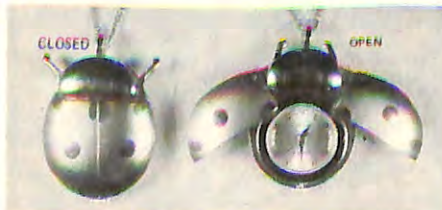

LADYBUG PENDANT WATCH

Closed, it's a lovely ladybug. Push the top and the wings open to reveal a fine, feminine watch with sweep second hand. This beautifully original creation comes complete with neck chain. Choose silver or goldtone. 2-yr. guarantee.

NEW Penguin pendant watch—wings open like ladybug watch. Black-white or blue-gold. Same guarantee. \$19.95 + \$1 pgt.-ins. or \$2 via air mail-ins.

Color catalog 50c

Oliver A. Kastel 3106KV N.E. 53rd St. Vancouver, Wash. 98663

Elks Family Shopper



SNUGGLE INTO SNOW BIRDS—warm and woolly Moccasins crafted with lamb skin on the inside, genuine reverse shearing on the outside. Soft padded soles and heel tab for easy slip-on. In beige with suede trim and hand-laced stitching. Sizes: 5-10, \$14 plus \$1.50 shpg. Vicki Wayne-ENS, 600 S. Country Club Rd., Tucson, AZ. 85716.



YOU STAY TOASTY WARM in your Damart Thermawear, even when it's frosty cold outside. Body-insulating underwear lets the perspiration evaporate through so you stay warm and dry next to your skin. Soft and light. Write for free catalog on a variety of styles and sizes including full length. Damart Thermawear, Dept. E117E, 1811 Woodbury Ave., Portsmouth, N.H., 03801.



U.S. Pat. 3733614

Solved!— The Ascot Problem

If your passion for Ascots is frustrated by their never staying in place — try our Open Collar Ties. Tailored to shape to your neck, they adjust to size and stay neatly in place with Velcro closure. The fabrics are 100% Polyester from Italy. Love them or your money refunded.

- Paisleys on colored grounds:**
Blue • Brown • Green \$8.50
 - Tattersal Checks on white grounds:**
Blue • Wine • Brown • Green \$7.95
 - Solid Shades:**
Navy • Wine • Brown • Green
Beige • Tan • Red • Lt. Blue
Rust • Yellow • White • Black \$6.95
- Add 75¢ Ship. 1st item, 50¢ ea. additional
Check or M/O

OST CRAVATES — DEPT E2
CHAMPLAIN, N.Y. 12919

In Canada: 6666 St. Urbain St., Montreal H2S 3H1

GIANT PLAYHOUSE BIG ENOUGH FOR 2 KIDS!



ONLY \$395 EACH
2 FOR \$5.95

FREE - 2" x 4" Name Plate fits on door. Can be personalized with child's name.

A child's dream come true! Size approx. 3 ft. high - 9 ft. square - 23 cubic ft. inside. Big enough for 2 kids to "Live" in this playhouse of their very own. Constructed of Safe, durable Polyethylene. Waterproof, use year 'round. Indoors and outdoors! Sets up in a jiffy . . . Nothing to assemble. No tools needed. Folds compactly for easy storage. Imprinted green and white brick walls with smiling daisies; English wrought-iron style door; sloping roof; easily fits any card table and in youngster's imagination it quickly becomes a LIFE-SIZE DOLL HOUSE for Girls . . . FARMHOUSE . . . RANCH HOUSE . . . PLAYHOUSE, etc.

This KING-SIZE PLAYHOUSE is our greatest bargain in years! **ONLY \$3.95 EACH.** Buy several!

SPECIAL OFFER: SAVE \$2.00. Buy 2 for only \$5.95. (Your Choice) Add \$1.00 for shipping and handling for each house. No C.O.D.'s.



ALSO AVAILABLE:
For Boys **GIANT WILD WEST FRONTIER CABIN.**

Same size, shape, price as GIANT PLAYHOUSE. Old West style. Split-log design. Only \$3.95 each.

ORDERS

SHIPPED PROMPTLY! XMAS DELIVERY GUARANTEED!

MONEY-BACK GUARANTEE

Send cash, check or money order to:

GIANT CABIN CO. Dept. 20.

165 Sutton Ave., Box 143 Oxford, Mass. 01540



Know your blood pressure

If your doctor recommends you keep close tab on your blood pressure, here's the perfect instrument. High-quality Aneroid-type with touch and hold sleeve fastener. No slipping. Accurate, easy-to-read gauge. Compact zippered case. Unconditional one-year warranty against defects in workmanship or materials. \$18.95 + \$1.00 postage. You'll need a stethoscope and we have an excellent one for \$4.95 + 50c postage. Money-back guarantee if returned ppd. within 30 days.

Dept. EK-117BU
Kintlen Co.
809 Wyandotte Kansas City, Mo. 64105



KING BED CONVERTER

Convert your twin-size beds into luxurious king-size bed in seconds! Just place comfortable polyurethane SPAN-A-BED between 2 twin-size beds. Fits snugly—you'll never know it's there. Save dollars—no need for special bedding. A full 6' long, 14" wide. Light, strong SPAN-A-BED will support the strongest man. Rolls up for easy storage when not in use.

\$4.99 + 75¢ hdlg.

holiday Gifts Dept. 711-7D
Wheat Ridge, Co 80036



1000 RETURN ADDRESS LABELS \$1.00

1000 gummed economy name and address labels printed in black with ANY name, address, zip code. Up to 4 lines. Order \$717 Set of 1000 Economy Labels (boxed) . . \$1.00

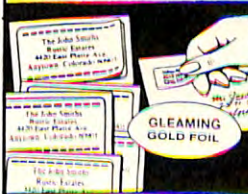

250 Self-Stick GOLD FOIL LABELS \$1.98

Glaming gold foil labels stick to any clean, dry surface—need no moistening. Rich black printing, classic border. Order P6128 Set of 250 Gold Foil Labels (boxed) . \$1.98

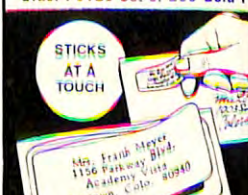

250 Self-Stick WHITE GLOSS LABELS \$1.98

Glossy white self-stick labels cling to any smooth surface—no moistening. Sharp black printing up to 4 lines. Order P6030 Set of 250 White Gloss Labels (boxed) \$1.98

Walter Drake 329-A Drake Bldg. Colorado Springs, CO 80940

NAME _____
ADDRESS _____
CITY & STATE _____ ZIP _____

___S717 1000 Labels @ \$1 each \$ _____
___P6128 Gold Foil Labels @ \$1.98 each \$ _____
___P6030 White Gloss Labels @ \$1.98 ea \$ _____

Add 20¢ per set for postage & handling \$ _____
SATISFACTION GUARANTEED Total \$ _____

Bearcat 210

POLICE & FIRE MONITOR
\$239.99

No crystals required, 5 band coverage, Low Band 32-50 MHz, Ham Band 146-148 MHz, High Band 148-174 MHz, UHF Band 416-470 MHz, "T" Band 470-512 MHz. Pick any 10 frequencies you want to scan and punch them in on the keyboard or select automatic search to find unknown frequencies. Operates on AC house current or 12-VDC for mobile operation. All power cords and brackets included for immediate operation. Scanner World discount price \$239.99 plus \$2.00 shipping. Call 518-436-9606 for COD orders or send money order or certified check with mail order. Catalog \$1.00, free with order.

Scanner World, USA

10-E New Scotland Ave., Albany, N.Y. 12208
518 - 436-9606

SAVE - CUT ON DOTTED LINE - SAVE

RADIO RERUNS

On Cassette Only \$2.98 Per Show!

Each 30 minute show as originally aired including commercials.

THE 20 BEST SHOWS EVER AIRED!

Buy 5 Get 1 Free!

Return to:
RADIO RERUNS
P.O. Box 11041
Minneapolis,
MN 55411

12. ABBOTT AND COSTELLO—Incl. "Who's on First"—All Time Classic 6/18/44
28. AMOS 'N' ANDY — "Kingfish's Travel Bureau" 4/47
103. AMOS 'N' ANDY — "Marriage Go Round" — All Time Classic
126. BABY SNOOKS — "The Opera" — Voted Best of Series
32. THE BICKERSONS — Argument at breakfast/Bedtime on a fishing boat/Anniv.
33. BOB AND RAY — Best of Their Comedy Routines "Bits & Pieces"
129. BURNS AND ALLEN — "Gracie Has Laryngitis" — All Time Best
123. EDGAR BERGEN & CHARLIE MCCARTHY — "Last Show" — Collectors Item
18. JACK BENNY SHOW — Last Radio Show, 1955 — A Collectors Must!
20. W.C. FIELDS — "The Day I Drank a Glass of Water" — All Time Classic
99. CBS NEWS ROUNDUP — Pearl Harbor attacked 12/7/41 — Hist. Collect. Item
100. GOLDEN DAYS OF RADIO—B. Crosby, J. Benny, A. & Andy, L & Abner, B. Hope
46. THE GREEN HORNET — "A Matter of Evidence" — All Time Best Show
48. INNER SANCTUM — "Only the Dead Die Twice"
67. LIGHTS OUT — "Cat Wife" with Boris Karloff — voted best of series 1938
62. THE SHADOW — "Death From the Deep" w/Orson Welles — All Time Best Show
153. SUSPENSE — "Sorry, Wrong Number" — All Time Best Show 2/14/60
91. "WAR OF THE WORLDS" w/Orson Welles, 10/30/38 Part I
92. "WAR OF THE WORLDS" w/Orson Welles, 10/30/38 Part II
97. 50 RADIO COMMERCIALS — 5C Pepsi, Ovaltine, & more from early days of radio

TO ORDER: 1. Circle the "Numbers" of the shows you wish to order. 2. Clip Ad and return with \$2.98 for EACH show ordered. 3. Be sure to choose 1 FREE show for each five shows you order. 4. Add 85¢ for shipping and handling.



HOLIDAY ENTERTAINING CAN BE FUN WITH E-Z TART SHELL FORMER

This is quite a tool for holiday or year-round entertaining. It can be used to make hors d'oeuvres or fancy pastries. All you do is put a bit of dough into the muffin pan (which is included), place the E-Z Tart shell former into the cup, and the tart shell forms . . . just like that! Recipes are included. \$29.95 ppd. Calif. residents add 6%. We pay shipping charges. Satisfaction guaranteed.

E-Z TART, INC.
444 Beaumont Dr.
Vista, Calif. 92083



SLEEP WARM BED WARMER

Here's the scientific way to keep warm—with the heat *under* instead of *over* you—on this FOUR-SEASONS comfort unit! Quality-made of long-wearing Cannon sheeting and polyester-filled.

New soothing, satisfying relief from sleeplessness, arthritis and circulation problems, it lies flat under bottom sheet. It's washable, 4-position ac/dc sleep-switch, and comes with a *five-year guarantee*. 39x76 twin \$30; or 54x76 full bed size \$32; 54x76 full size, dual control \$38; 60x80 queen size with dual \$46; 78x84 king size with dual \$48, all postpaid. Enclose check or M. O. only—Mich. residents add 4% sales tax.

THE LINEN CLOSET
1324 Welch Blvd. Flint, Michigan 48504

Elks Family Shopper



YOU WON'T FALL ASLEEP AT THE WHEEL with Travel-Mate Doze Detector to keep you awake. Cigarette-pack size, it has a tiny electric sensor that monitors your body's "attitude," sets off an alarm if you start to doze. \$14.95 plus \$1.75 shpg. 2/\$24.95 plus \$3.25 shpg. Jay Norris Corp., 31 Hanse Ave., Dept. 105-26, Freeport, N.Y. 11521.



LAST U.S. SILVER COIN SETS. Never again will silver be used in coin mintage. Most silver coinage has already been remelted so these coin sets increase in value all the time. 1964, \$4.50; 1963, \$5.25; 1962, \$5.50; 1961, \$6.50; 1960, \$7. All 5 sets, \$27.50. Sets mounted in lifetime holder. Centre Coin Co., Box 1, Dept. K-11, Sherman Oaks, CA. 91413.

Shows Actual Size

YOUR NAME & ADDRESS
(and/or anything else you want)
Printed Like This on 2 to 5 Lines
ON 300 GUMMED LABELS

WORLD'S BEST GIFT

Labels of De Luxe Quality! Large & readable. Print (not typewriter) type. Centered lines. Rich blue ink. Snow-white gummed paper. Any copy up to five 35-character lines. Sparkling gift box. 300 for \$2.00. Any 3 orders, only \$5.00. 4-wk. del'y. Ppd. & guaranteed.

SEND NO MONEY NOW! Pay for labels after they arrive and prove satisfactory.
Writewell Co., 842 Transit Bldg. Boston 02115

See Advertisement on Inside Back Cover

You try our famous Haband SHOES AT NO RISK!
HABAND COMPANY, 265 N 9th St.,
Paterson, N. J. 07530

2 Pairs for only **19⁹⁵** We Pay Postage

Sirs: Please send me _____ pairs for which I enclose \$_____. I have checked my choice of style, size, & color and I await with interest. SHIP AT ONCE!
THIS ORDER GETS FREE TWO-WAY BELT!

Keep the belt even if you return shoes for full refund!
72B-441(916) Belt size _____

STYLE	Size	Width
BLACK Reptile		
BROWN Reptile		
BROWN Side Buckle		
BLACK Loafer		
BROWN 'Gator		
BROWN Executive Boot		

Name _____
Street _____ Apt. # _____
City _____
State _____ Zip _____



OLD TIME PLAYER PIANO

Bring back memories of yesteryear with miniature wooden music box that cranks out nostalgic tune "The Entertainer". Sliding panel doors, rotating musical cylinders and matching bench—just like the original player pianos! A great collector's item. 4" x5". \$9.99 plus \$1.00 postage.

holiday Gifts

Dept. 711-7C, Wheat Ridge, Colo. 80036

GENUINE "OLD WEST CHARM"



ORNAMENTAL UNIQUE

The gift so ideal on the desk, mantel, top of the mailbox, in the garden, or model layouts. Conversation piece! Authentic replica! Made in USA, 1/20 Scale. 17 inches tall. Bronze bearings! The top revolves and wheel turns with slightest air movement!

\$11.95
Postage Pre-Paid

Comes to you attractively kit boxed. Illustrated instructions! Mail check or money order to:

Toyne Distributors
P.O. Box 4293, Missoula, MT 59806

Elks Family Shopper

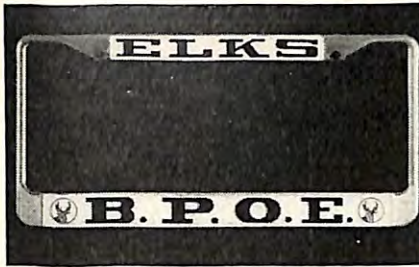

LICENSE PLATE FRAMES are beautifully styled for Elks, triple-chrome plated, engraved with 3 brilliant baked-enamel colors. \$4.98 per pair, ppd. Write on lodge letterhead for information on custom-designed frames with lodge number. F. C. Enterprises, 4825 W. Torrance Blvd., Suite 11, Torrance, CA 90503.

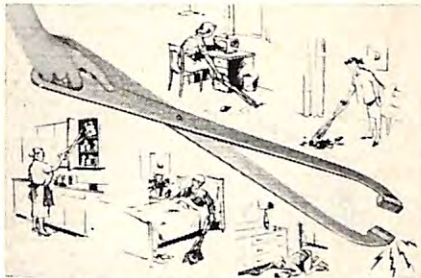

THE GREAT GRABBER grabs far-away objects and brings them finger-tip close. Its scissor action picks up objects up to 27" away. Never stretch, stoop, climb on precarious perches. Holds sponge to mop up spills, dust rag for high places and has a magnetic tip to pick up pins. \$7.49 ppd. Better Sleep Inc., Dept. EL11, New Providence, N.J. 07974.

BACK-ACHE

STIFF NECK TENSION
WONDERFUL RELIEF
NEW TECHNIQUE

NO DRUGS, BED REST OR SURGERY. USERS REPORT IMMEDIATE RELIEF & ENJOY TENNIS, GOLF, ATHLETICS. . . RELIEVES TENSION. Mail for free brochure, no salesman will call.

"NATURAL TRACTION CORP."
516 Alahmar (PO 590)
Alhambra, Calif. 91802



THE EXALTED RULER ("TO MY BROTHERS")

Charles M. Russell's greatest Masterpiece, painted for the Elk Temple and signed, "To My Brothers," reproduced in full color. Print is on heavy stock 15"x20". \$8.50 per print, two for \$14.50. Mailing and handling included. Satisfaction guaranteed. Send check to:

MOUNTAIN MAN PRINTS
Box 6611, Rm. 47, Great Falls, Mont. 59406

"You bet
your life
this beats
jogging
outdoors."

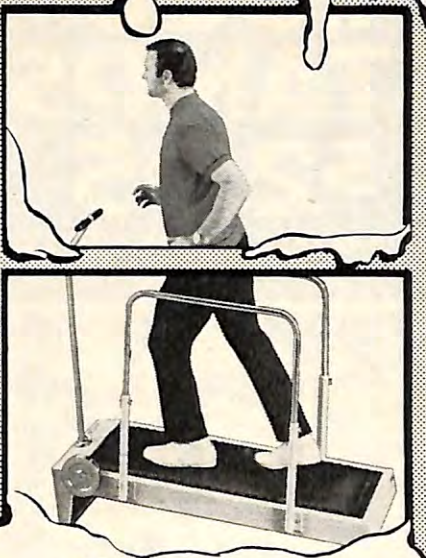

"You bet I like cutting my jogging time by 75% in any weather—even snow, rain, cold and darkness.

"I compress the benefits of an hour of outdoor jogging into an easy 15 minutes indoors, simply by jogging on a scientifically designed inclined 'treadmill'.

"I jog in private, in the comfort of my own home—regularly, so it'll really do me good.

"And I build up my heart and lungs, and shed excess weight—to look, feel and sleep better, and help get a new lease on life.

"I jog on equipment that's used in health clubs and gymnasiums across the country—precision equipment that's built to last—the Battle Creek Health Walker."

Battle Creek Equipment Company, Dept. 12K
307 W. Jackson St., Battle Creek, Mich. 49016



Yes—I'd like to find out how I can own a Battle Creek Health Walker and jog to my heart's content for just pennies a day. Please rush full details with no obligation to buy to:

Name _____
Address _____
City _____ State _____ Zip _____

Mystery Electronic Top

Greatest New
Gadget
In Years.



Handsome
Gift Box

A Look into the Future!
Spins for days on Invisible Power
Unique Christmas Gift

What Makes It Go On and On and On at 2500 r.p.m. with no apparent energy source? **BAFFLING BRAIN BUSTER** that **BUGS** the brightest demonstrated at science fairs and conventions. The higher their IQ the more puzzled they are. **Perpetual Motion solved at last!** The answer to **UFO & Flying Saucer?** Let the whiz kids examine it, start it stop it or whatever. **Psychic Power? Anti Gravity? (Yes, but more!)** Scientific Break thru from Space? (Partially) You'll laugh at some explanations. Magic, Mystery & Science combined. **Keeps spinning WITHOUT ANY ENERGY LOSS!** Fascinating fun at parties, science classes, etc. Carry in pocket ready to fool and entertain friends & wise-guys. Never wears out. **Spins indefinitely on Invisible Wireless Power** that you can defy anyone to See, Understand or Explain! Beautifully made with plastic base and black saucer shaped spinner. Patented. Complete with secret scientific explanation. Orders shipped same day received. **Unlimited Money Back Guarantee.** Send check or money order for \$7.95 each. Add \$1.00 shipping. Save. Get 3 for \$22.65 postpaid. 6 for \$43.00 postpaid. Dealer Inquiries Invited.

Johnson Smith Co., 35075 Automation Dr.,
Dept. 7311, Mt. Clemens, Mich. 48043

FREE! Catalog of 1800 Novelties, Tricks, Jokes,
Odd Scientific, Hobby and Fun Items.

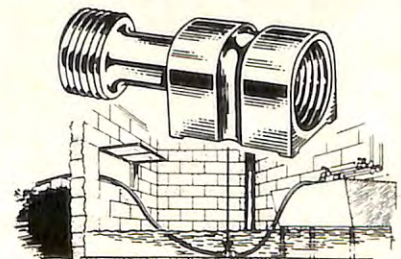

DRAIN FLOODED CELLAR FAST

Needs No Electric Motor or Gas Engine

To drain out a cellar, pool, vat, cistern, excavation, boat, don't break your back hand-pumping or bailing. Just connect your garden hose to nearby water faucet and free end to intake side of **DRIN-DRI**. Connect another length of hose to discharge side, turn on faucet, and normal water pressure makes the Drainer work. This siphon pump has no moving parts to wear, jam or break down. Only \$3.99 plus 60¢ handling and postage. Satisfaction guaranteed or money back.

LARCH, Dpt. 202-A, Box 770 Times Sq. Sta., N.Y. 10036

1,000 STAMPS \$2.95

(GUARANTEED WORTH OVER \$30 AT STANDARD CATALOG PRICES)



Reward yourself now! A great opportunity to increase the value of your present collection or to start a new one. Get 1,000 different U.S.A. & Foreign stamps from over 55 countries: Animals, Space, Olympics, spectacular Old and New Issues included — Plus big 80-page Collector's Catalog (everything to enjoy the World's Most Rewarding Hobby!) — just for agreeing to look at other sensational stamp values from our 10-Day Free Examination Approval Service. Buy any or none, return balance, cancel service anytime. The 1,000 Stamps & Catalog are yours to keep when sending only \$2.95 NOW!

MONEY BACK GUARANTEE!

KENMORE STAMP COMPANY

Milford OT-963, New Hampshire 03055

I enclose \$2.95. Rush me 1,000 Stamps (worth over \$30 at Standard Catalog Prices!) PLUS 80-page Collector's Catalog.

Name.....

Address.....

Zip.....



Photo Jigsaw Puzzle

Looking for a unique gift idea? We can turn your favorite photo into a deluxe 8" x 10" jigsaw puzzle. Full color or B/W depending on the photo you send. Mail the print or negative (returned unharmed) and \$3.95 ppd. For rush orders send an additional \$2.00 and we'll ship your puzzle 1st Class mail the same day it's received. Turn somebody on — the suspense will kill them!

P.S. Better prints make better puzzles.

AMERICAN STUDIOS

Dept. EM-11, La Crosse, Wisc. 54601

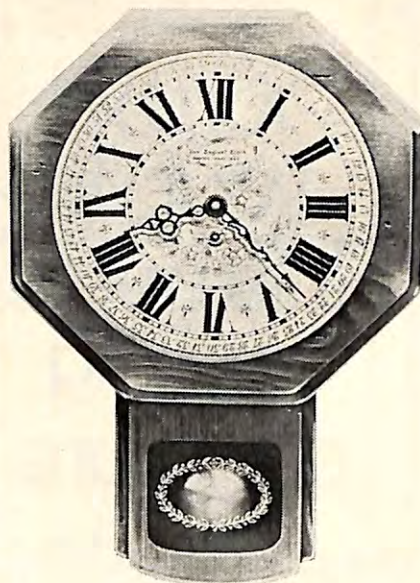

SCHOOLHOUSE CLOCK—This stunning time-piece is an authentic replica of an old schoolhouse clock. It's been hand-crafted from native American pine and has a rich antique finish. The hand-painted dial is highlighted by bold Roman Numerals, black hands and second hand. It operates on the world's most advanced cordless electric clock movement. Runs for up to 2 years on a single "C" battery (included). Clock measures 12½" wide x 18½" high by 3½" deep. Price is only \$69.98 to your door. CA Res. Tax \$4.20.

M. C. DONALD'S SELECT PRODUCTS

3760 Peacock Court
P.O. Box 2367 Dept. ME
Santa Clara, CA 95051

Burpee's New 1978 Garden Catalog-FREE

Featuring new, exciting vegetable and flower varieties for the home gardener.

The new 184-page Burpee Garden Catalog is yours free. It is a comprehensive planting and growing guide, with over 1400 vegetables, flowers, fruits, shrubs, trees, and garden aids. Plus many helpful hints from Burpee's horticulture experts on how to have a better, more productive garden.

If you ordered from Burpee last year, you will automatically receive your Burpee Catalog in January.

BURPEE SEEDS

1908 Burpee Bldg., Warminster, PA 18974; or Clinton, IA 52732; or Riverside, CA 92502 (Please mail to nearest address.)

Yes, please send me the 1978 Burpee Garden Catalog FREE.

NAME..... (PLEASE PRINT)

ADDRESS.....

CITY.....

STATE..... ZIP.....

Elks Family Shopper

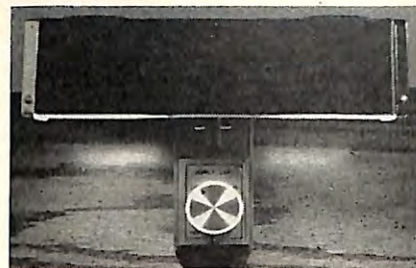

DUAL-LIGHT HIGH INTENSITY BED LAMP is easy on the eyes. Two horizontally-mounted high intensity bulbs are in brown/brass fixture that clamps easily on any 1" or 2" headboard. Dimmer switch lets you adjust light level. Comes with 8' cord. \$29.50 plus \$1.50 shpg. J. W. Holst, Inc., Dept. EK-117, 1864 S. US-23, East Tawas, Mich. 48730.

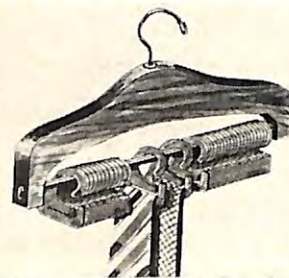

MIGHTY MI-TIE HANGER takes care of ties in style. Solid walnut hanger has brass hook and cross bar with plastic removable riders for individual hanging. American-made in 3 sizes: 6", 25-tie size, \$8.40; 10" holds 45 ties, \$10.40; 16" holds 75, \$12.75. Ppd. (Less with heavy ties.) Sleepy Hollow Gifts, 6651 Arlington Blvd., E11, Falls Church, VA. 22042.

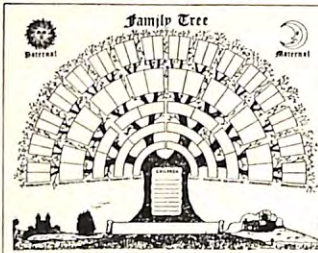

FAMILY TREE CHART

Lovely heirloom parchment chart, 11"x14", for six generations. Frame and display as permanent record. Mailed in heavy storage tube.

Only \$2.50 ppd or 3 for \$6.00

Personalize? Surname in Old English, add \$1.75 ea.

WINSOME PLACE

Box 171-E, Cedar Crest, New Mexico 87008



Kraus originals
"like wearing gloves on your feet"

WOMAN'S CAVALIER

Handsome crafted in genuine leather. Smooth no-seam vamp, adjustable buckle strap. Resilient ribbed sole and 1" heel. COLORS: Black, Brown, Navy, Luggage Tan, Bone, White, Wine. Full & half sizes: 6-10½ AAA, AA and 6-10½ A, B, C widths. **\$22** plus \$1.50 postage

VICKI WAYNE-ENB

600 S. Country Club, Tucson, AZ 85716



"CHUNKY THICK" INITIALS and cut-outs make sparkling bright necklaces. Almost 3/4" high and crafted in gold electroplate with matching 16" or 18" "S" chains. Choose a Star, Crescent, Shamrock, Heart, Arrow, Butterfly or an initial: A B C D E F G H J K L M N P R S T V. \$2.98 plus 40¢ shpg. Happy House, Dept. CH-E, 2631 Merrick Rd., Bellmore, N.Y. 11710.



EMBARRASSING HAIR on your face, arms, legs can be removed easily by Perma Tweez, the electrolysis device that safely and permanently removes unwanted hair without puncturing the skin. Clinically tested and recommended by many dermatologists. \$19.95 ppd. General Medical Co., Dept. ELE-15, 1935 Armacost Ave., W. Los Angeles, CA. 90025.

GIANT MAGNIFIER



Enlarges and illuminates by built-in light. Perfect for close-up reading, examining stamps, coins, and paintings! Sturdy chrome plated handle holds two "C" batteries (not incl.). Satisfaction guaranteed. Send just \$6.99 + .75 post. & hdlg. (N.Y.S. Res. add 5% tax)

ROYAL GIFTS

P.O. Box 11-008, Dept. EL-117B, Albany NY 12211

GRANDMA'S GROUP



These unique little cut-outs are hand painted and mounted on wooden boards with beige background. \$6.00 per plaque with 2 children (plus \$1.20 post. & hand.) Add \$1.00 for each additional child. Sizes from 6"x8" and up depending on number of children. Size shown is 8"x10". Give name, sex, color of hair when ordering. Also available as "Grandpa's Gang", "Daddy's Darlings" and "Moms Little Angels"; or your choice of title.

If you want to see more of JoDee's "Little People," send 50¢ for catalog.

JoDee Originals

Dept. E11, Box 1094, Lk. Worth, FL 33460

TRY THIS NEW PIPE "FREE" FOR 30 DAYS!

So different that it's patented by the UNITED STATES GOVERNMENT patent number 3267941



This top grade Mediterranean briar incorporates a sensational invention that contradicts every idea you've ever had about pipe smoking. It completely eliminates breaking-in. Tars, sludge, bite, and bitterness never reach your mouth. You get cleaner, cooler, tastier, moisture-free thoroughly enjoyable smoking. You can try it before you buy it.

E. A. Carey

It's the first pipe in the world that's guaranteed to give unadulterated pleasure to smokers.

Give it 30 days—

No cigarette, no cigar, nor any other pipe can give you the full rich flavor, aroma, deep down satisfaction, enjoyment, and peace of mind that you get from a Carey Pipe.



You may be a pipe smoker with a rack full of pipes and still searching for the ideal smoke, or perhaps you would like to switch to a pipe to cut down on cigarettes or expensive cigars.

The Carey Pipe may look like any ordinary pipe, but it's a lot different! In fact, there's nothing like it in the whole world. The Carey Pipe is made of the finest aged mediterranean briar—but, its big secret lies in the exclusive patented "MAGIC INCH," cleverly concealed in a bite proof nylon stem.

It's Not a Filter

The "Magic Inch" is not a filter that gets soggy and loaded with foul smelling goo. A soggy foul smelling filter transmits its stale foul odor into each successive puff of smoke, creating more problems than it solves.

It's Not a Trap

The "Magic Inch" is not a trap collecting moisture that gurgles with every draw. It is not a trap that must be cleaned after every smoke.

It's Almost Magic

Not my magic but NATURE'S OWN MAGIC. Warm winds pick up moisture by evaporation from the oceans, lakes, rivers, and streams, lift it high into the atmosphere where the cooler upper air squeezes it into drops of water that fall back to earth in its most perfect state of purity. Just as the colder upper air of the atmosphere causes rain, the cool air entering the "Magic Inch" chamber through the special louvers of the patented Carey stem, causes immediate condensation of the moisture in the smoke where it drops to the bottom of the chamber, is absorbed by the natural fiber sleeve of the "Magic Inch," and in turn, is evaporated into the outside air. No accumulation ever remains to form sludge or slugs of bitter tasting goo. The "Magic Inch" also mixes purifying oxygen with the smoke from the

tobacco, in perfectly controlled proportions, cooling the smoke, eliminating all tongue bite, and creating MELLOWNESS, MILDNESS, and SWEETNESS that was never before enjoyed in pipe smoking.

Today, over one hundred and fifty thousand pipe smokers smoke Carey Pipes almost exclusively. They all got started by accepting my most unusual offer to test a Carey Pipe for 30 days, without any risk on their part whatsoever.

They were all granted the same option, an option which is yours also. After 30 days, if you agree that the Carey Pipe is the best smoke of your life, you may keep it; if you don't agree, whack it with a hammer and return the broken pieces to me. The trial has cost you nothing! How many businesses are that sure of their product?

Make Your Own 30 Day Test

Clip out the coupon below. Fill in your name and address and send it to me TODAY. I'll send you a full color brochure, absolutely free, so you can select your favorite style and shape for your 30 day trial.

E. A. Carey, Dept. 204T, 3932 N. Kilpatrick Ave., Chicago, Ill. 60641

Okay Mr. Carey. Send me your full color brochure so I can select a pipe to smoke for 30 days on a free trial basis.

Name _____
Address _____
City _____
State _____ Zip Code _____



WELSH TWEED TRILBY

This traditional informal British hat is made of the best Welsh tweed, 100% wool from the hills of Wales, fully lined. The pattern is a subdued olive brown dog's tooth or black and white dog's tooth.

Welsh Tweed Trilby \$18.50 ppd.

State size—6 3/4 through 7 7/8

State color

Satisfaction Guaranteed

Send for our unique catalog

AUSTRAL ENTERPRISES
Box 70190, Seattle, Washington 98107



TEAKWOOD PLATES AND WINE GOBLETS

What a great gift! These beautifully hand-carved pieces will be cherished forever. Made of teakwood, the most sought after wood in the world. Age and usage actually enhance their beauty. Plate is 12" in diameter, goblet 5" tall.

#016 Wine Goblet \$3.98 #017 Set 4 Goblets \$14.98
#388 Plate \$7.98 #389 Set 4 Plates \$27.98

10-Day Money Back Guarantee
Send check or money order to —

SEVERN GIFTS

622 Oakland Hills Dr.
Dept. 8-E11 P.O. Box 148
Arnold, Maryland 21012



**PENNA.
DUTCH
TASTE
TREAT!**

**WEAVER'S famous
SMOKED BACON**

Gourmet quality! Full slab or sliced!

Our bacon is trimmed from choice, carefully selected corn-fed porkers, then smoked in our old-fashioned smokehouses. The thick billowy smoke completely penetrates the bacon from both sides, producing an exceptionally rich smoky flavor.

Send for yours today! Money-back guarantee!
6 to 8 lb. slab—\$2.50 lb. ppd.
4 1-lb. pkgs. sliced—\$10.75 ppd.
No C.O.D. Send check, M.O. or use Bank Americard, Master Charge, or American Express. Include all numbers and your signature.

SEND FOR FREE COLOR CATALOG
OF WEAVER'S SMOKED MEATS.

WEAVER'S P.O. BOX 525-D29
LEBANON, PA. 17042

NON-METAL TAPS



SAVE HEELS
Quiet,
No-Skid,

Run-down in 3 months Like new Steel-Tough with NO-NOISE

Amazing polyurethane taps keep heels perfect for months. Attach in seconds to any heel, and no one can tell you're wearing taps. Men or ladies size.

KICKSHOE REPAIR COSTS TODAY!
Money-back guarantee.

7 pair only \$2. 12 pr. \$3.
(Can save you \$4.00 in heels) ©1971
HALE HEEL COMPANY
44 Chip Rd., Middlefield, Mass. 01243

FLASHING ELKS JEWELRY

Gold plated National ELKS Bola Ties or Pendants really light up!



Red & Green computer-type light-emitting diodes flash brilliantly. Runs 100 hours on replaceable hearing aid batteries (incl.), with 1 year warranty, 10-day money-back guarantee.
Specify: Bola tie for men or Pendant for lady ELKS.
ONLY \$11.95 ppd.
Ariz. res. add 5% tax
Available from:
BOB HAAKER & ASSOCIATES
P.O. Box 27306
Phoenix, AZ 85061

MIGHTY 4-OZ. POCKET SCOPE

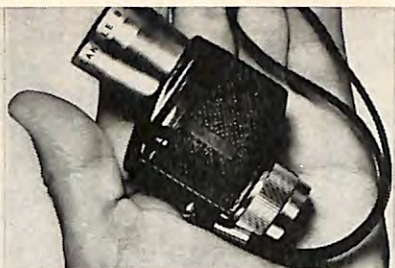

A miracle 8 power—with the panoramic view of a full-size binocular! The magic of powerful optics at your fingertips wherever you go. The 8 power Bushnell (Baush & Lomb) Pocket Scope is great for travel, hiking, nature study, spectator sports, and theatre. 437° field at 1000 yards. Use lens 24 mm by itself as a close-up magnifying glass to study stamps, coins. Use for many other fascinating adventures. 3½" long, weighs only 4 oz., fully coated lenses. Complete with handsome zippered carrying case and wrist strap. Only \$29.95 plus \$2.00 p&h. Great Gifts.

Send Check or M.O. 15 day money back guarantee.
J. W. Holst, Inc. Dept. ES-117, 1864 E. US-23
East Tawas, Michigan 48730



LOOK SLIM AND TRIM!

Have a pot belly? Put it in its place! Look and feel more attractive the minute you put it on. Instant grip Velcro fastener makes it easy to put on and take off. 6" wide, adjusts from 26-50" Machine wash. For men and women. \$4.99 plus 70¢ pstg.

HOLIDAY GIFTS

Dept. 711-7B, Wheat Ridge, Colorado 80036

READ-EAT-WATCH TV



A joy for bed readers, a must for convalescents and a welcome gift for all. This elegantly grained mahogany plywood Folding Back Rest is super size. 16"x24" high. A full 4 to 6" higher than other back rests. It gives full pillow support to head and back for firm sitting-up comfort. 5-adjustable positions. Vertical elastic cords hold your own pillow securely in place. Non-skid base. Conveniently light, it folds wafer-thin—no storage problem. \$12.98. Order from this ad, we'll pay postage, ship promptly. NJ residents add 5% tax.

Send Check or Money Order to — **Better Sleep Inc.** MONEY BACK GUARANTEE QUALITY PRODUCTS SINCE 1951
Box ET, New Providence, NJ 07974

Elks Family Shopper



YOU CAN WRITE IN THE DARK with Nitewriter Pen. When there's no available light, just place pen's cap on top and pen lights up. Gift-boxed with bulb, batteries, extra ink cartridge. Perfect for doctors, nurses, police, pilots, etc. \$7.98 plus 75¢ shpg. (N.Y. res. add 4%.) Royal Gifts, Dept. EK-107, P.O. Box 11-008, Albany, N.Y. 12211.

FREE REPORT
How to Get Rich in MAIL ORDER WORLD TRADE BUSINESS.
B. L. Mellinger
Famed World Trader

FREE REPORT ON STARTING A MAIL ORDER BUSINESS. B. L. Mellinger, famed world trader, tells how to start part-time at home, how to buy products below wholesale, how to write and place ads—with little or no capital. Write for free details. No salesman will call. Brainerd Mellinger, Dept. E-239BF, 6100 Variel, Woodland Hills, CA. 91367.

DON'T GET ROBBED!
\$525 PLUS 75¢ POSTAGE
Here's a smartly styled belt that's as practical as it is handsome. It has a secret zippered inner pocket for safely hiding away one's money. 2" wide, leather, available in brown with gold-plated buckle or black with silvery rhodium buckle. Sizes 28 to 44, with up to 3 initials on buckle. Specify color, size, initials. Send check or MO, no COD'S.
BARCLAY, Dept. 51-M
1575 North Dixie Hwy, Pompano Beach, Fla. 33060

ELKS EMBLEM BELT BUCKLE

Beautifully hand engraved, Nickle and German Silver with blue and white inlay. Size 4" x 2¾". Approved by Grand Lodge.
\$30.00 prepaid



McGEE ENTERPRISES, INC.
P.O. Box 21040 • Denver, Colorado 80221
 Check Money Order

Name _____
Address _____
City _____ State _____ Zip _____



AMERICANA FIREPLACE RUG protects carpet from flying sparks, cinders, soot. Handsome flame-resistant rug is treated with flame-retardant chemicals to help protect floor and carpet. Heavy black duck with gold eagle. 45"x22 1/2" semi-circle to fit snugly against hearth. \$5.99 plus 50¢ shpg. Holiday Gifts Inc., Dept. 711-7E, Wheat Ridge, Colo. 80036.



THE ONLY W. C. FIELDS RECORDING ever made is the laugh-filled W. C. Fields "Temperance Lecture." You'll delight in listening with your friends to the witty, humorous "Evils of Alcohol." Includes 10,000-word biography, film stills, 8 songs by Mae West. \$4.95 plus 75¢ shpg. 2/\$9.95 ppd. J. W. Holst, Inc., Dept. ET-117, 1864 E. US-23, East Tawas, MI. 48730.

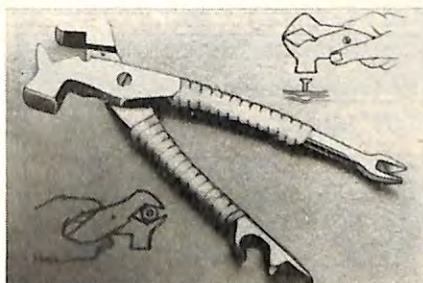

7 TOOLS IN ONE. Chromed steel hammer tool is a wrench, pliers, wire cutter, screwdriver, bottle opener, tack or nail remover. Vinyl-wrapped handles give insulated, firm grip. Full 8". Use for home, office, car, boat or camper. \$5.95 plus \$1.50 shpg.; 2 for \$11 plus \$2 shpg. Catalog 50¢. Kastel, 3106K N.E. 53rd Ct., Vancouver, WA 98663.

READ SMALL PRINT EASILY
With Fashionable Half Frame
Reading Glasses From France



New vision power is yours with these French fashion magnifying glasses that aid the natural powers of your eyes. Have normal distance sight without removing them. In french tortoise, duotone smoke & blue, or smoke & cognac. Specify men's or women's. Not for astigmatism or eye diseases. Free case. Personalized with 2 gold initials. \$1.00 add'l.

\$895

Add 50¢ Handling

JOY OPTICAL no orders for N.Y. del'y
Dept. 615, 73 Fifth Ave., New York, N.Y. 10003

Sun Shield

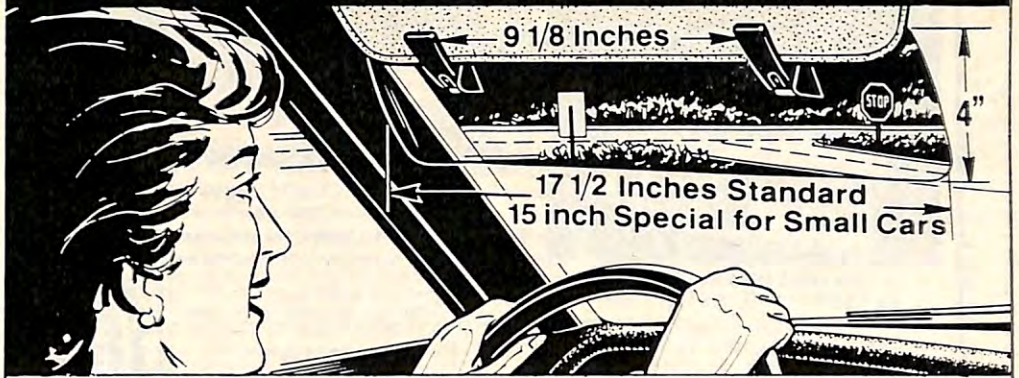

DOUBLES your driving COMFORT

- Reduces ALL GLARE and HEAT, front or side, Day or Night
- Accepted by leading safety authorities • Positive screw clamps hold securely
- Universally adjustable for look-through or shade-and-look-under.
- **SATISFACTION GUARANTEED** (Return within five days for full refund)

THE IDEAL GIFT • MOST ENJOYED • MOST APPRECIATED

Sun Shields, Inc. • 9179 General Court • Plymouth, MI 48170



Check or money order enclosed; Michigan residents ONLY add 4% tax.

\$5.00 for one Sun Shield, shipped postpaid promptly.

\$9.00 for 2 Sun Shields - Make your passenger comfortable, too!

\$42.00 Doz. (minimum, one order) for group buyers - fleet owners.

Specify 15 in. LENGTH (not car model) for sub compact & small foreign cars.

Name _____ Street _____

City _____ State _____ Zip _____

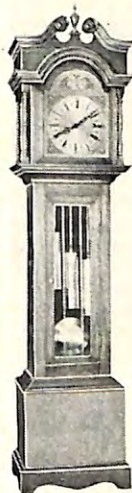

Superior.

The Mason & Sullivan
Clock you build.

The finest woods and imported movements distinguish Mason & Sullivan's 19 different styles of floor, wall, and mantel clocks—all replicas of classic antiques. Send \$1 for catalog and plans to build grand-father clock shown, or 50¢ for catalog alone to: **MASON & SULLIVAN CO.** Dpt. ELN8/39 Blossom Ave. Osterville, Mass. 02655.

NATIONAL DOLL WORLD

- There is nothing about dolls, doll patterns, doll clothes patterns (or anything else on dolls) that you won't find here! **EVERYTHING!**
- Over 100 complete doll patterns, doll clothes patterns, doll accessories, etc., Published Annually!
- Doll patterns, doll clothes patterns, doll house patterns, doll gossip, doll exchanges, doll contests, doll photos, doll accessories, patterns and designs, doll news, doll letters, doll club, doll book review, doll stories, doll antiques, etc.!

JUST \$4.00 per yr. Published Bimonthly!

NATIONAL DOLL WORLD
Box 336 BC, Seabrook, N.H. 03874

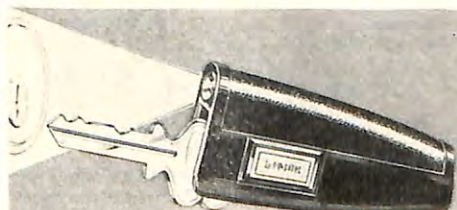

MIRACLE LIGHT KEY CASE!

No more fumbling in the dark for the key hole! Just squeeze—instant light guides your key to the lock, or your steps to the door. Self-regenerating power cell lasts for years. Lightweight, but holds your 3 most important keys. Great for gifts; \$5.50 postpaid. NJ residents add 5% sales tax.

MOLLY MALONE

Dept. AA, 206 Route 46, Fairfield, NJ 07006

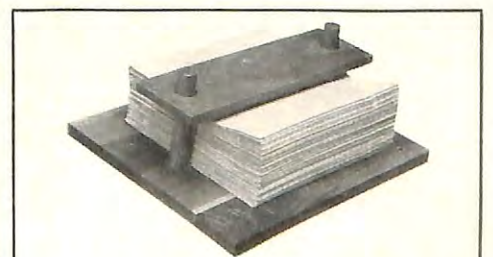

Solid American walnut napkin holder. Quality craftsmanship to complement fine dining room appointments. Authentic hand rubbed Danish oil finish—spillproof, natural looking, with lovely wood grain. **VILLAGE WOODCRAFT**, Box 1964, Grand Rapids, Michigan, 49501. Napkin holder \$24.50, plus \$2.00 for shipping.

Not ANOTHER shirt for Christmas!
Save \$2.00 from prices below on a gift that's more



THIS CHRISTMAS SAVE \$2.00 ON A GIFT THEY'LL USE EVERY DAY!
 A Spear nameplate for mailboxes, lamp posts, and lawns! Attractive signs that are personalized—so they can't be duplicated—and functional—so they won't stay in the closet never used. Permanently formed in rustproof aluminum with raised white reflective letters on a tough black enamel coating. Space for 17 letters/numbers on long plate (18" x 2 1/2"); 6 on short plate (7" x 2 1/2"). But hurry—offer expires December 23.

We ship in 48 hours / Satisfaction guaranteed or your money back.

SINCE 1949
Special ENGINEERING COMPANY
 Dept. 4849 Box 7025, Colorado Springs, Colo. 80933
 Up to 17 letters & numbers on long plate — 6 on short plate
ANY WORDING YOU WANT

hot line
 You can order anytime
 24 hours a day
 Call us at
 (303) 471-9850

STYLE _____
 Ordered by _____
 Address _____
 City-State-Zip _____
 Earn extra money fast — send for details

PRICE \$ _____
 POSTAGE & HANDLING \$1.60
 TOTAL \$ _____



7 1/2 FOOT MINIATURE WINDMILL makes a great landmark on your lawn. The original Doty Windmill is 7 1/2 feet high and has a no-rust, hard aluminum tower, pivot block, all-steel wheel and tail vane with ball bearings in wheel. Hand-balanced to withstand hard winds. Silver-trimmed with red. \$53.95 ppd. (CO. add 3% tax.) Personalized tail vane, add \$5. Dealer inquiries invited.

LADD, INC., Dept. EL
P.O. Box 158, Wiggins, CO 80654
 Check enclosed or Money Order
 Name _____
 Address _____
 (Please Print)

STOP GUESSING YARDAGE

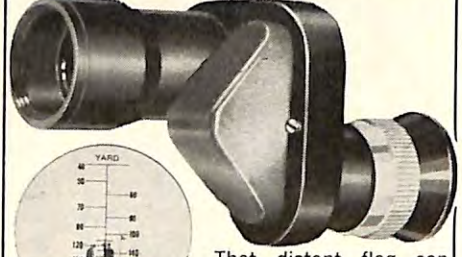

That distant flag can easily fool you—is it 150 yards, 170 or 190 yards? With our compact (2" long) precision Golf Scope you can accurately judge the distance from your lie to the flag. Also helps you see your golf ball on the fairway, brings it six times closer! Weighs only 2 oz. 6 power, 15mm coated lens. Scale indicator is plainly legible, but can double as a tiny telescope. Field of view at 1,000 yards is 390 feet. Complete with instructions, neck strap, carrying case. Only \$29.95 plus \$2.00 pp & hdlg. Great gift.
 14 day Money Back guarantee.
J. W. HOLST, INC. Dept. ES-117, 1864 E. US-23
 East Tawas, Mich. 48730

Elks Family Shopper

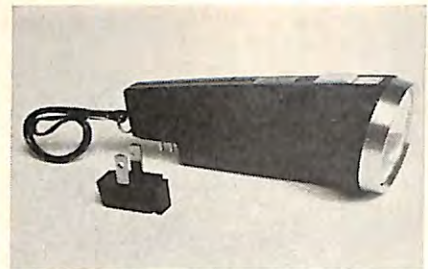

RECHARGEABLE FLASHLIGHT needs only occasional recharging in any electric outlet. Weather-proof, it has a strong, powerful beam. Comes with plug-in adapter, carrying strap, built-in magnet. Case has hidden spare bulb. 5 3/4" long. \$14.99 plus \$1.00 shpg. J. W. Holst Inc., Dept. EK-117, 1864 E. US-23, East Tawas, Mich 48730.

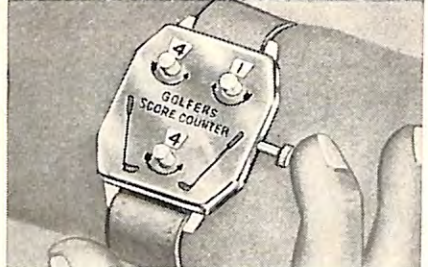

KEEP YOUR GOLF SCORE on your wrist, easily recorded, readily visible on wristband Golf Scorer. You wear it like a watch and record strokes and scores which are automatically totalled. 3 different windows show count. Tarnish-proof metal case with nylon strap. \$3.99 plus 50¢ shpg. Holiday Gifts Inc., Dept. 711-7C, Wheat Ridge, Colo. 80036.

CUSTOM MADE EMBLEMS

Organizations, Schools, Churches, Commercial and etc. Free Brochure Dept. CM 10E

F12 EMBLEMATIC JEWELRY \$1.15
 75¢ ea. ELKS, K of C., MASONS, ETC. 75¢ ea. D.P. 25¢
 Free brochure Dept. EJ 12E
Fraternal Wholesale Jewelry Mfg. Co.
 P.O. Box 8123, Cranston, R.I. 02920
 (401) 942-4591

New sleep comfort without extra pillows.



Enjoy new comfort with your back, shoulders and head gently raised and cushioned on this light buoyant foam wedge. Provides an even, gradual slope for more healthful, restful sleep. Head Elevation comforts diaphragm hernia, hypertension, acid regurgitation, breathing, bronchial and heart ailments. Leg Elevation eases varicose circulatory and swelling leg discomforts. 27" long. Washable zipper cover. **FOAM-SLANT** is available in heights most often prescribed by doctors. Order 4" high for two pillow users \$15.00; 7 1/2" high for three pillow users. \$17.00; or choose extra high 10" at \$20.00 or 12 1/2" at \$23.00. Order from this ad, we'll pay postage, ship promptly. NJ residents add 5% tax.
 Send Check or Money Order to —
Better Sleep Inc.
 Box EN, New Providence, NJ 07974

MONEY BACK GUARANTEE
QUALITY PRODUCTS SINCE 1951

How To Trace Your Family Tree

A new book by David Poteet, former Assistant State Archivist of Virginia and Ph.D. in History.
 Thorough, easy to understand. Explains how to do research, use sources, and solve typical problems. Lists many addresses and helpful books.
 Order your copy today. (Copies make welcome gifts, too). 14-day money back guarantee if not satisfied.

David Poteet

CRAWFORD PUBLISHING CO.
 Dept. E. P.O. Box 2279, Danville, Virginia 24541
 Send me _____ copies of HOW TO TRACE YOUR FAMILY TREE. I enclose \$4.50 plus 50¢ postage and handling for each copy (Virginia residents add 4% sale tax).
 Total amount enclosed: \$ _____ (Check one: _____ cash; _____ check; _____ money order)
 NAME _____
 ADDRESS _____
 CITY _____ STATE _____ ZIP _____

PERSONALIZED GOLF TEES

2-1/8" WOOD
THE PERFECT GIFT FOR EVERY GOLFER
Box of 50 — \$5.95
 plus 50c postage
 Additional orders \$3.95 + 25c post.
 Orders shipped in 48 hours

SATISFACTION GUARANTEED
 All orders received by Dec. 18 guaranteed delivery before Xmas.

TEEGO INDUSTRIES Dept. E
 8 Sterling Ave., Yonkers, NY 10704

Elks Family Shopper

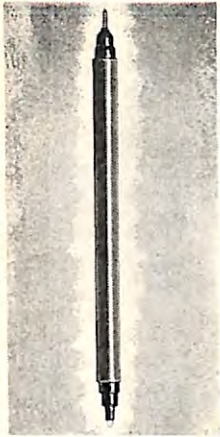

SELF-CORRECTING BALLPOINT PEN. When you make a mistake with your ballpoint, don't tear up the paper and start all over again. Turn pen around and use the eradicator tip on reverse end to wipe it out instantly. Capped to protect pocket or purse. 5 for \$4.98; 12 for \$9.98 plus \$1 shpg. per order (PA. res. add sales tax.) American Consumer, Dept. SRP15, Caroline Rd., Philadelphia, Pa. 19176.



NEW 5 HP TRAIL BRONC from Heald is powered by a 197 cc 4-cycle engine. Has automatic torque sensing transmission, wide flotation tires and shocks front and rear. Trail Bike comes in easy-to-build kit form at \$299.95. Ideal for hunting, fishing, camping. For more information, write Carl Heald Inc., Dept EKN, P.O. Box 1148, Benton Harbor, MI 49022.



GOLFER'S DIVOT FORK & GROOVE CLEANER

Golf's most useful tool! Use the fork to lift and level on-the-green divots perfectly in seconds (no more jabbing with a tee), and to clean shoe cleats and balls. Use the 5 tiny nubs on the bottom of the handle to scrape clean the grooves of the irons like magic, cleans all the grooves of each iron in 2 passes to achieve proper backspin on each shot. Only 2 1/2 inches long, hangs on golf bag or keychain. Solid stainless steel, guaranteed forever. Owner's initials smartly engraved. Full price \$5.00 each. Money back if not delighted. We ship in 2 days. Mail to ELGIN ENGRAVING CO., 953 Edwards Ave., Dundee, Illinois 60118.

See Advertisement on Back Cover

Jay Norris Corp., 31 Hanse Ave., Dept. 105-28, Freeport, N.Y. 11521

Please rush me the following 106-Pc. Professional Socket Wrench Tool Set:

- 1 Set for \$14.99 purchase price + \$3.00 postage, handling and insurance. #91995
- 2 Sets for \$27.99 purchase price + \$5.00 postage, handling and insurance. #92002

Enclosed is check money order for \$
Sorry, no C.O.D.'s (N.Y. res. add sales tax)

PLEASE PRINT:

Name

Address

City

State

Zip

©Jay Norris Corp., 1977



The Touch

by Regency

\$239⁹⁸ 16 channel scanner

SCANNER WORLD, USA now offers you the most advanced scanning monitor available in the world today — "The TOUCH," manufactured 100% in the United States by Regency, makers of the world's first transistor radio.

FEATURES AND SPECIFICATIONS

- * Search or scan. You can either search through all bands for unknown frequencies, or listen to the stored frequencies you've selected for the sixteen (16) scanning channels. Either way you can scan any combination of 16 channels in Lo, Hi or UHF Band, creating a total of 15,357 different frequencies available at your fingertips.
- * Frequency range Lo Band 30-50 MHz, Hi Band 146-174 MHz, UHF Band 440-512 MHz.
- * Receives all public service frequencies including police, fire, ambulance, mobile telephone, FBI, Customs, VHF marine, 2 meter amateur, plus many others.
- * Comes equipped with AC power cord for home use, DC power cord for mobile use, telescopic antenna and complete operating instructions for immediate use upon receipt.
- * Automatic scan delay momentarily stops the scanning after a call, to wait for a reply.
- * Has priority control switch so that you can automatically override calls on other channels and never miss a call on your favorite frequency.
- * Discover "Live" frequencies you never knew existed by activating automatic search with a single touch.
- * No crystals required — never buy another crystal.
- * One year warranty.
- * Weather alert receiver will automatically alert you in the event of a severe weather warning broadcast by the National Weather Service (subject to availability by local weather service transmitter).
- * Save over \$110.00 from manufacturers suggested list price of \$349.99 because of Scanner World's massive buying power.
- * From SCANNER WORLD, all of the above can be yours for only \$239.98 plus \$2.00 shipping. Call 518-436-9606 now to place a Master Charge or COD order by phone. Direct mail orders to the address below, including money order, Master Charge information, or we will ship your order COD. Catalogue \$1.00, free with order.



10-E NEW SCOTLAND AVE.
ALBANY, NEW YORK 12208
518-436-9606

SAVE — CUT ON DOTTED LINE — SAVE

SAVE — CUT ON DOTTED LINE — SAVE



HAND EMBOSSER

FOR PERSONALIZED STATIONERY

Emboss your own personal stationery for a lifetime by just pressing a handle. Makes expensive looking raised letter impressions on paper & envelopes. Print clearly 3

lines desired (maximum 24 characters a line) \$10.95 + \$1.25 post. For 4 lines add \$1.50 Extra plate \$9.50. Pa. res. add 6%. Catalog 25¢.

POSTAMATIC CO.

Dept. E-1177, Lafayette Hill, Pa. 19444



Mens and Womens Handsewn Double Glove Leather MOCCASINS

Handcrafted from soft glove leather. Cushioned insole and rawhide laced. Mens #7901 6 1/2 to 13 \$15.95 ppd. Womens #7911 5 to 10 \$13.95 ppd. Free color catalog with order or send 25¢ for catalog with 92 additional styles of moccasins for men, women and children. Send check or money order to:

CAVEMAN SHOES Dept. EQ-2
P.O. Box 61, Murphy, Ore. 97533

—SORRY— FOR ELKS ONLY



"You can see all... in the VU-ALL" Elks emblem permanently embossed in VELVETONE COWHIDE NOW, IT'S HERE! The "VU-ALL" billfold made especially for ELKS by a company with 68 years of know how in producing leather goods. Patented "VU-ALL" pass case eliminates fumbling for your passes and the clear vinyl windows will never crack or cloud up. Also has a secret bill compartment and two handy spare key slots for an extra car and house key.

MONEY BACK GUARANTEE SEND NOW!
Write for FREE Brochure of gifts. \$11²⁵ ppd.

THE-CASS-LINE

P.O. Box 85, Galion, Ohio 44833
Ohio residents add 1% sales tax.

8 PIECE B.P.O.E. 11 O'CLOCK COASTER SET

Cabinet with 8 B.P.O.E. Slide Out Coasters All Solid Wood!

For the hostess with most est... Elegant decorator cabinets to adorn the buffet, cocktail table or bar... Service for eight. Clock face set in cork for drinks. Coasters are 3 3/4 inches wide and 4 3/4 inches deep. As useful as they are beautiful! You'll want one for your own and several to give.

Send \$4.95 plus \$1.00 for postage and handling to:

HUBERT AKINS' GIFTS
836 West Marshall
Longview, TX 75601



REGULATOR CALENDAR CLOCK
 Bring the grace and beauty of early America into your home. This stunning wall clock is a replica of the regulator calendar clocks made in the mid-1880's. Shows both the hour and the day of the month. Powered by an 8-day spring wound pendulum movement. The case is hand-crafted from solid northern pine and finished in "olde antique" regular finish or "olde antique" dark finish. Measures 29" high x 15 1/2" wide x 6 3/4" deep. Comes fully guaranteed. No. 048 REGULATOR CLOCK (regular finish) \$179.95. No. 049 REGULATOR CLOCK (dark finish) \$179.95 + \$2.20 p/pd. DEE'S, 5878 Marshall St., Dept. EM107, Oakland, CA 94608.
 (Calif. residents add 6 1/2% tax)

100" DIAG. PICTURE From Your Portable Color or B&W Television Projection Distance 7 Ft. EASY TO ASSEMBLE—NO TOOLS NEEDED.



100" diag. picture at about 7 ft. from wall, sheet or screen. You control size picture you wish. NO fancy do-dads, bulky over priced outmoded glass lenses or ugly dangerous concealing cabinets. KIT includes Fern-ber precision concentric acrylic lens, mirror, pre-cut plywood, post focus assembly, base and tv bed and illustrated plans. PHOTO ABOVE TELLS A THOUSAND WORDS.
 Prompt Delivery. GUARANTEED TO WORK
 Factory Price \$49.50 f.o.b.
THE TOWERHOUSE CO. Dept. EL-1
 1267 Stuyvesant Ave., Union, N.J. 07083
 Phone (201-688-0921)

Elks Family Shopper



INSTANT TELEPHONE AMPLIFIER attaches to your phone to provide maximum hearing in noisy areas. Fits securely with snug-fitting band to phone. Has adjustable fingertip-touch volume control. Carry in pocket or purse for use in public telephones. Ideal for elderly, hard of hearing. \$19.95 ppd. Stadri, 147-47-6th Ave., E11, Whitestone, N.Y. 11357.

A WORKSHOP AT YOUR FINGERTIPS

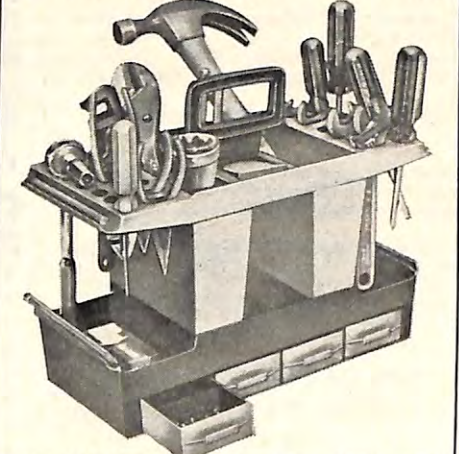

TOOL-MATE keeps both hand tools and small parts handy and organized... Ready to use... for the handyman or hobbyist. 39 different tool-holding slots. Two Jumbo storage wells for storing large items, hammers, flashlights, etc. Four drawers for storing parts, nails, screws, etc. Everything stored in an easy-to-use, easy-to-find position. Use on the job, home or farm. Beige and Brown of Hi-Impact heavy-duty polystyrene. Assembles easily on tools needed. Size 11 1/2" H. x 14" L. x 7" W.
 Only \$7.95 + \$1 pp.
 SAVE two for \$14.95 + \$1.50 pp.
 Send Check or M.O. 15 day money back guarantee.
J. W. HOLST, Inc. Dept. EM-117, 1864 E. US-23 East Tawas, Michigan 48730

TRY A BURKE ELEVATING CHAIR FREE FOR A WEEK.

The Burke Chair helps you all the way to a standing position—safely and gently. Send for a free catalog. Then, if you desire, select the recliner, rocker or contemporary of your choice. And try it free for a week in your own home.



ASK ABOUT MEDICARE COVERAGE!

BURKE
 P.O. Box 1064, Dept. E-1177
 Mission, Kansas 66202
CALL TOLL-FREE
1-800-255-4147

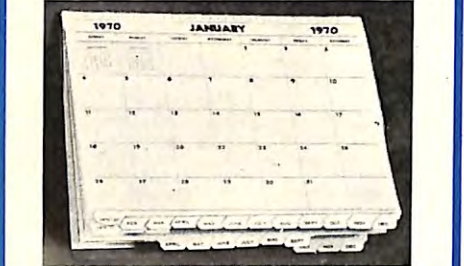

3-YEAR ENGAGEMENT CALENDAR for 1978, 1979 and 1980. Great for planning ahead and looking back. Has 36 11"x8 1/2" month-at-a-glance type pages with spacious squares for each day's reminders. Spiral-bound to lie flat. Stout covers. For wall or desk. \$2.50 plus 90c shpg. 2/\$5.00 ppd. Writwell Co., 843 Transit Bldg., Boston, MA. 02115.



ELKS CUFF LINKS and TIE TACK
 Here is one of our many fine quality jewelry accessories emblematic of ELKS membership. ELKS everywhere will welcome a gift of this handsome 20K gold plate tie tack in latest design and gold mesh wrap-around cuff links. Enameled emblems combined with bright cut swirl and Florentine styling. Chain and bar clutch on tack. Tie Tack \$3.65. Cuff Links \$9.20. Set \$11.95. All prices F.O.B. Chicago. For a complete selection of up-to-the-minute accessories of superb design and craftsmanship, write for catalog.

RUSSELL-HAMPTON CO.
 Dept. E, 2550 Wisconsin Avenue
 Downers Grove, Illinois 60515

FAMOUS COLORADO 1860 \$20 GOLD PC. STRUCK IN 10K SOLID GOLD



\$29.50
 (3 for \$85)
 SHOWN EXACT SIZE!

Collector's item to hand down to future generations! 'Private Gold' was originally struck in the 1860's by assayers and banks. Limited quantity now minted as originals are valued up to \$90,000!

- SOLID 10K gold... not 'filled' or plated!
- Plus serial numbered certificate of gold authenticity!
- Display case and history included! 10 DAY MONEY BACK GUARANTEE!

Ideal as gold necklace! Golden holder (bezel) — \$8.00.

Centre Coin Co., Box 1, Dept. LK-11 Sherman Oaks, CA 91413 — Enclosed please find _____ for _____ gold coin(s) plus _____ for golden holder (bezel). Please add \$1.50 for insurance & handling. Mastercharge BankAmericard Exp. Date _____
 Acct. No. _____
 Name _____
 Address _____
 City _____ State _____ Zip _____
 Due to gold fluctuation, we may withdraw offer at any time. CA residents add 6% sales tax.

French Milled Gift Soap



Delightfully scented, mild complexion soap that's perfect for special gifts. Alabaster white with delicate (permanent!) floral design for ladies. Set of two per gift box - \$3.25 or save on three boxes at \$8.75. Robust fragrance and handsome design, Mr. D. Soap will complement your favorite man! Set of three per gift box - \$4.75 or save on three boxes at \$12.50. Prepaid. Va. residents add 4% sales tax. NO C.O.D. BankAmericard or Master Charge! Include Card No. and Expiration Date. OR Send Check or M.O. to:

SPINELLA'S GIFT DEPT.
 608 Industry Drive / Hampton VA 23661

Cancer is often curable.

The fear of cancer is often fatal.

If you're afraid of cancer... you're not alone. But some people are so afraid that they won't go to the doctor when they suspect something's wrong.

They're afraid the doctor might "find something." This kind of fear can prevent them from discovering cancer in the early stages when it is most often curable.

These people run the risk of letting cancer scare them to death.



THIS SPACE CONTRIBUTED BY THE PUBLISHER AS A PUBLIC SERVICE

ONE ARMED BANKER



This sporty ONE ARMED BANKER holds \$100 in dimes. Actually works and pays on winning combinations just like its big brothers in Las Vegas. Ideal for home bar or office. Size 11x6x6 inches, weight 5 lbs. Comes in red. American made. Guaranteed. Not a gambling device.

HAVE FUN SAVING MONEY

ORDER NOW AND MAKE YOUR FRIENDS GREEN WITH ENVY. \$49.95 PRICE INCLUDES POSTAGE. (ILLINOIS CUSTOMERS PLEASE INCLUDE \$2.50 SALES TAX).

H. L. LaSOTA, DEPT. EL
611 HIRSCH AVE., CALUMET CITY, ILL. 60409



BOOK OF MEMORY

in everlasting bronze
For listing 100 to 3250 names of deceased members economically. Write for free catalog showing photos of hand-chased cast bronze plaques.

NEWMAN BROTHERS, Inc.
5625 Center Hill Avenue
Cincinnati, Ohio 45216

Louder and Funnier

(Continued from page 32)

I am deeply touched, but not as deeply touched as you have been in coming to this luncheon." And when he addressed a gathering of the National Association of Manufacturers—not the most friendly of audiences for a liberal President—he remarked on the fact that he and William McKinley were the only two Presidents ever to speak before the NAM. "I suppose," he quipped, "that President McKinley and I are the only two that are regarded as fiscally sound enough to be qualified."

Kennedy's "amiable irreverence," as one observer of the period termed it, was aimed at anybody and everybody, not excluding his own family. At a dinner of the Alfred E. Smith Foundation during the 1960 campaign, he said with a characteristic twinkle: "I had announced earlier this year that if successful I would not consider campaign contributions as a substitute for experience in appointing ambassadors. Ever since I made that statement I have not received one single cent from my father."

I must confess I miss that kind of humor among today's political higher-ups. Laughter, it has been said, "is more than a defense mechanism, a means of adjusting to circumstances, a safety-valve against tyranny—it is an agency in creative enterprise." And so I say to those in high places: Louder and funnier. For I stand squarely with the Kennedys, the Coolidges and the rest of their whimsical company. And also with the English writer and satirist, Max Beerbohm, who said, "Strange, when you come to think of it, that of all the countless folk who have lived before our time on this planet, not one is known in history or in legend as having died of laughter."

Obituaries

PAST DISTRICT DEPUTY Walter A. Brouette of Missoula "Hell Gate," MT, Lodge died August 12, 1977. District Deputy Grand Exalted Ruler in 1964-1965, Brother Brouette served the West District.

PAST DISTRICT DEPUTY William A. O'Neal of Madison, TN, Lodge died July 30, 1977. Brother O'Neal was appointed District Deputy Grand Exalted Ruler in 1972-1973 for the Middle District.

WILLIAM W. GARVIN of Santa Ana, CA, Lodge died August 9, 1977. A Past Exalted Ruler of his lodge, Brother Garvin was Secretary to the late Grand Exalted Ruler L. A. Lewis in 1947-1948.



ATTENTION!

"BPOE" Elks rings and emblems, the finest in lodge jewelry. Over 400 factory outlets coast to coast.

Lodge secretaries and members write for free catalog and name of nearest factory representative.

REIS-NICHOLS, INC.

141 South Meridian Street
Lower Level
Indianapolis, Indiana 46225

Phone (317) 635-4467

Manufacturers of Fraternal
Lodge Jewelry—Since 1919

BINGO



Largest Manufacturer and Distributor of BINGO Supplies

Free Catalogues available for:

- ★ Complete bingo supplies
- ★ Tables & chairs
- ★ Fund raising through group travel
- ★ Flags & banners
- ★ Armchair races
- ★ Jar & breakopen tickets

ALL STAR BINGO INC. Dept. E-11
P.O. Box 2816, Clearwater, Fla. 33517
Toll Free Call 800-237-9885

GIVE FOR CHRISTMAS

NEW step by step method picture booklet opens door to **CLOSET WINE MAKING**. Mailed direct or to you. Order NOW! Send \$2.50 to:

Concord Press, Dept. E
Box 22211, Concord, Tn. 37720

MOVING SOON?

Please let us know, as soon as you know what your new address will be. Be sure to supply us with both your old and new address, including the address label from your current issue. Copies we mail to your old address will not be delivered by the Post Office unless you pay extra postage.

ATTACH ADDRESS LABEL HERE

My new address will be:

NAME _____

ADDRESS _____

CITY _____ STATE _____ ZIP _____

Mail to: Circulation Manager
The Elks Magazine
425 W. Diversey Pkwy.
Chicago, Illinois 60614

Deluxe Home Stereo 8-Track System

HIGH-FIDELITY STEREO PLAYER

ADVANCE 1978 MODEL



LOOK AT ALL THESE DELUXE FEATURES!

- SEPARATE HI-FI STEREO VOLUME AND BALANCE CONTROLS
- LIGHTED AUTOMATIC CHANNEL INDICATOR
- BOTH AUTOMATIC AND MANUAL CHANNEL CHANGE SELECTOR
- LOW BASS/HIGH TREBLE TONE CONTROL
- EXTRA LONG QUICK CONNECT 5 FT. SPEAKER CORDS
- PHONO INPUT JACK FOR TURNTABLE HOOKUP
- RICH WOOD GRAIN WALNUT FINISHED CABINETS
- RECEPTOR JACK FOR HEADPHONES

Acoustically balanced solid-state components deliver REAL STEREO HI-FI PERFORMANCE

Enjoy your favorite music in thrilling lifelike stereo! Professional quality deluxe 8-track system is engineered with advance solid-state electronics to bring you the finest in true stereo performance, for all 8-track cartridges. Power amplifier console has full control panel with both automatic and manual channel change selector, professional-type separate volume and balance controls, lighted channel indicator and full bass/treble tone control. Also has built-in receptor jack for head phones. Twin stereo speakers are acoustically balanced for full rich lifelike sound. Extra long 5 ft. speaker cords allow speakers to be positioned for maximum stereo effect. There's even a convenient phono input jack. Deluxe cabinets are beautifully styled with rich walnut grain finish. Power console measures: 13½"x4"x8". Speaker cabinets measure: 7½"x13"x4".

\$39⁹⁵

LIMITED TIME OFFER
AT THIS LOW PRICE

ORDER NOW

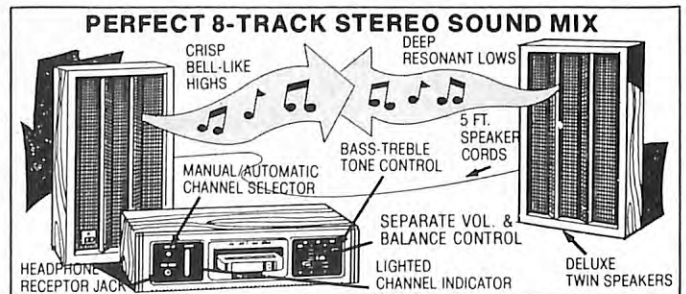

GUARANTEE

You must be completely satisfied with your deluxe stereo 8-track system or you may return it for a prompt and courteous money back refund.



ELECTRONICS INTERNATIONAL
CHICAGO ILLINOIS 60606
A division of Robert Kahn Enterprises, Inc.

MONEY BACK GUARANTEE

ELECTRONICS INTERNATIONAL Dept. TH-2
210 SOUTH DESPLAINES STREET CHICAGO, ILLINOIS 60606

YES! Please rush on Money Back Guarantee the complete 3 pc. Deluxe Home Stereo System at \$39.95 plus \$2 for postage and insurance.

Ill. residents only, please add 5% sales tax.

I am enclosing \$ _____ Send C.O.D. I enclose \$2 deposit

Name _____

Address _____

City _____ State _____ Zip _____

YOU MAY CHARGE YOUR PURCHASE

Master Charge Acct. No. _____

Interbank Acct. No. (find above name) _____

BankAmericard Acct. No. _____

American Express Acct. No. _____

Credit Card good thru _____

Signature _____

Go with the style leaders! This is the look you will see in the newest, most expensive executive shoe lines. The lighter looking, highly shined luxury shoes you have always wished you had when you've seen them on the handsome corporate president or the best-dressed man at the Country Club.

And yes, your suspicions are correct! Many such men are regularly paying \$65 to \$85 per pair for their footwear! But you do not have to lay out such painful high prices to enjoy the fashion excitement and the new lighter, far more comfortable design. Haband, the mail order people from Paterson, N.J. sell more than a million pairs of shoes per year to on-the-ball executives who have found out about our direct-to-your-home service and the important savings!

TAKE ANY 2 PAIRS for only 19⁹⁵

in your EXACT SIZE

And GET THIS EXTRA TWO WAY BELT FREE!

OVER 50,000 Pairs ON HAND

All 100% man-made in U.S.A.

Now you are invited to participate: In conventional accounting practices, 2 pairs for \$19.95 is impossible today. But this new line is specially discount priced to make your acquaintance. Look over the pictures carefully. Read our luxury specifications. Then let us show you what we can do!

*This elegant high fashion belt is black on one side, brown on the other. Custom made for these shoes!



2 pairs for 19⁹⁵ AND A FREE BELT!

But these are NOT CHEAP SHOES!

They are the new longer wearing executive shoes, lasted on full fitting executive lasts and made from new materials that scuff at scuff, are completely waterproof & hardly ever need a shine. You get the tough, life-of-the-shoe one-piece heel and sole. Flexible built-in support shank in the arch. Built-in elastic side gores. Sturdy heel counters. Heavy metal buckles & trim. Full side zipper on boots. Comfortable, roomy box toe construction and excellent fit for both size and width!

Note for Conservationists: Above new reptile grain is man-made so you save enormous money on the fashion and never hurt the reptile!

HABAND

265 N. 9th St., Paterson, NJ

All Weather Executive Boots

Are You Fed Up with Higher and Higher Shoe Prices?

HERE'S WHAT YOU CAN DO:

Send for 2 pairs. Try them on. Wear them around. Show your friends. Then decide!

KEEP THIS GUARANTEE!

If at any time you are not 100% delighted, return the shoes for full refund of every penny you paid us!



New Side Buckle Loafer

Even the Boot! 2 for 19⁹⁵

SHOES AT NO RISK!

2 Pairs for only 19⁹⁵ We Pay Postage

HABAND COMPANY 265 N 9th St., Paterson, NJ 07530

Sirs: Please send me pairs for which I enclose \$ I have checked my choice of style, size, & color and I await with interest. SHIP AT ONCE!

Is Your Size on this Chart?

	5½	6	6½	7	7½	8	8½	9	9½	10	10½	11	12	13
A														
B														
C														
D														
E														
EEE														

THIS ORDER GETS FREE Two Way Belt! Keep the belt even if you return shoes for full refund!

728-441 (916)

BELT SIZE:

Name

Street

City

State ZIP CODE

Apt. #

STYLE	Size	Width
BLACK Reptile		
BROWN Reptile		
BROWN Side Buckle		
BLACK Loafer		
BROWN Gator		
BROWN Executive Boot		

2 pairs 19⁹⁵ Black Slip-On & Brown Gator Grain Use Coupon to see this Incredible Value →

106
PIECE

AMAZING LOW-PRICE OFFER!
on this Mechanics All-Purpose
SOCKET WRENCH & TOOL SET

The Complete Workshop That You've Always Wanted!

Makes Any Job Go Quicker... Easier

6-pc. Screwdriver & Tool Set
with Interchangeable Blades —
complete with Pouch

18-pc.
Hex Key Set
in its own Pouch

over
200,000
sold.

Everything
You See Here —
\$14⁹⁹
106
Pieces
only
(2 sets only \$27.99)

4-pc. Cold
Chisel Set

10-pc. Drill Bit Set
with Fitted Case

REVERSIBLE
RATCHET

ADAPTERS

21 SOCKETS
3 FULL DRIVES
1/2" • 3/8" • 1/4"

11-pc. Chrome
Socket Set —
1/2" Drive

Convenient All-in-One
Plastic Carrying Pouch
for All Three Socket Sets

10-pc. Chrome
Socket Set —
3/8" Drive

8-pc. Chrome
Socket Set —
1/4" Drive

1/2" • 3/8" • 1/4
"L-HANDLES"

**THE PERFECT
TOOL KIT FOR HOME,
AUTO, BOAT, SHOP,
FARM!**

METAL
TOTE BOX

18-pc. Ignition
Wrench Set

LOWEST PRICE EVER
FOR THIS
PROFESSIONAL
SET!

5-PIECE
OPEN END
WRENCH
SET

7-pc. Nut Driver
Set with its
own Pouch

UNBEATABLE
FOR QUALITY AND VALUE!

FULL SET INCLUDES: • 11-pc. 1/2" drive Socket Wrench Set with 8 Sockets, Reversible Ratchet, "L-Handle" and Adapter. • 10-pc. 3/8" drive Socket Wrench Set, including 8 Sockets, "L-Handle" and Adapter. • 8-pc. 1/4" drive Socket Wrench Set, including 7 Sockets and "L-Handle". • Handy Plastic Pouch for three Socket Sets. • 8-pc. Interchangeable Screw Driver and Tool Set • 7-pc. Nut Driver Set. • 5-pc. Open End Wrench Set. • 4-pc. Cold Chisel Set. • 18-pc. Ignition Wrench Set. • 18-pc. Hex Key Set. • 10-pc. Drill Bit Set. 106-Pc. Set

USE THIS SOCKET SET FOR 90 DAYS. IF NOT COMPLETELY SATISFIED
RETURN FOR PROMPT REFUND OF PURCHASE PRICE.

Jay Norris Corp., 31 Hanse Ave., Dept. 105-28, Freeport, N.Y. 11521
Please rush me the following 106-Pc. Professional Socket Wrench Tool Set:
 1 Set for \$14.99 purchase price + \$3.00 postage, handling and insurance. #91995
 2 Sets for \$27.99 purchase price + \$5.00 postage, handling and insurance. #92002
Enclosed is check money order for \$..... — Sorry, no C.O.D.'s
PLEASE PRINT: (N.Y. residents add sales tax.)
Name _____
Address _____
City _____
State _____ Zip _____

© Jay Norris Corp., 1977

**106 WAYS TO SAVE BIG MONEY
YEAR AFTER YEAR!**

Home handyman, amateur mechanic, or just plain tinkerer—here's your chance to get a whole work shop of professional quality hand tools . . . in their own handy tote box—all at an unbeatable low price! Equip yourself with this tremendously versatile, amazingly complete outfit . . . and you're ready for just about any repair job that comes along!

JAY NORRIS CORP. JAY NORRIS Corp., 31 Hanse Ave.
Dept. 105-28, Freeport, N.Y. 11521
Serving Satisfied Customers for over 25 Years
Canadian Residents please send orders to: JAY NORRIS CAN LTD.
8595 Langeller Blvd., Dept. 105-28, St. Leonard, Quebec H1P3B6